

---

## Heritage Advisory Committee

**Date:** February 11, 2025  
**Time:** 9:30 AM  
**Location:** Council Chambers, Civic Centre, 2nd Floor  
300 City Centre Drive, Mississauga, Ontario, L5B 3C1  
and Online Video Conference

### Members

Councillor Stephen Dasko	Ward 1
Councillor Dipika Damerla	Ward 7
Councillor Brad Butt	Ward 11 (Chair)
David Cook	Citizen Member (Vice-Chair)
Alexander Hardy	Citizen Member
Antoine Musiol	Citizen Member
Jahnvi Pathak	Citizen Member
James Holmes	Citizen Member
Jason DeBrum	Citizen Member
Lucy Zita	Citizen Member
Matthew Wilkinson	Citizen Member
Somayyeh Nezhad Bagher	Citizen Member
Terry Ward	Citizen Member

**To Request to Speak on Agenda Items** - Advance registration is required. To make a Deputation please email Temi Adeniyi, Legislative Coordinator at [Temi.Adeniyi@mississauga.ca](mailto:Temi.Adeniyi@mississauga.ca) or call 905-615-3200 ext. 8587 no later than **February 7, 2025 before 4:30 PM**.

**Questions for Public Question Period** – To pre-register for Public Question Period, questions may be provided to the Legislative Coordinator at least 24 hours in advance of the meeting. Following the preregistered questions, if time permits, the public may be given the opportunity to ask a question on an agenda item. Virtual participants must pre-register.

**Virtual Participation** - All meetings of the Heritage Advisory Committee are streamed live and archived at [Mississauga.ca/videos](http://Mississauga.ca/videos). To speak during the virtual meeting or if you do not have access to the internet, contact the Legislative Coordinator and you will be provided with directions on how to participate. Comments submitted will be considered as public information and entered into the public record.

### Contact

Temi Adeniyi, Legislative Coordinator, Legislative Services  
905-615-3200 ext. 8587 | Email: [temi.adeniyi@mississauga.ca](mailto:temi.adeniyi@mississauga.ca)

### Find it Online

<http://www.mississauga.ca/portal/cityhall/heritageadvisory>

Meetings of Council streamed live and archived at [Mississauga.ca/videos](http://Mississauga.ca/videos)

1. **CALL TO ORDER**

2. **INDIGENOUS LAND STATEMENT**

“We acknowledge the lands which constitute the present-day City of Mississauga as being part of the Treaty and Traditional Territory of the Mississaugas of the Credit First Nation, The Haudenosaunee Confederacy the Huron-Wendat and Wyandotte Nations. We recognize these peoples and their ancestors as peoples who inhabited these lands since time immemorial. The City of Mississauga is home to many global Indigenous Peoples.

As a municipality, the City of Mississauga is actively working towards reconciliation by confronting our past and our present, providing space for Indigenous peoples within their territory, to recognize and uphold their Treaty Rights and to support Indigenous Peoples. We formally recognize the Anishinaabe origins of our name and continue to make Mississauga a safe space for all Indigenous peoples.”

3. **APPROVAL OF AGENDA**

4. **DECLARATION OF CONFLICT OF INTEREST**

5. **MINUTES OF PREVIOUS MEETING**

5.1 Draft Heritage Advisory Committee minutes dated January 14, 2025

6. **DEPUTATIONS**

Any member of the public interested in making a deputation to an item listed on the agenda must register by calling 905-615-3200 ext. 8587 or by emailing [Temi.Adeniyi@mississauga.ca](mailto:Temi.Adeniyi@mississauga.ca) by **February 7, 2025 before 4:00 PM.**

Each Deputation to Committee is limited to speaking not more that 10 minutes.

Pursuant to Section 57.1 of the Council Procedure By-law 0044-2022, as amended:

Deputations shall be received and the matter shall be referred to staff for a report, unless there is a resolution or recommendation passed to “receive” the Deputation. After a Deputation is completed, Members shall each have one opportunity to make a preamble statement and ask questions to the Deputant(s) or staff for clarification purposes only, and without debate.

7. **PUBLIC QUESTION PERIOD - 15 Minute Limit**

**Public Comments:** Members of the Public that have a question about an item listed on the agenda may pre-register by contacting the Legislative Coordinator at least 24 hours in advance of the meeting. Following the registered speakers, if time permits the Chair will acknowledge members of the public who wish to ask a question about an item listed on the agenda. Virtual participants must pre-register.

Pursuant to Section 58 of the Council Procedure By-law 0044-2022, as amended:

The Heritage Advisory Committee may grant permission to a member of the public to ask a question of the Heritage Advisory Committee, with the following provisions:

1. Questions may be submitted to the Clerk at least 24 hours prior to the meeting;
2. A person is limited to two (2) questions and must pertain specific item on the current agenda and the speaker will state which item the question is related to;
3. The total speaking time shall be five (5) minutes maximum, per speaker, unless extended by the Mayor or Chair; and
4. Any response not provided at the meeting will be provided in the format of a written response.

8. **CONSENT AGENDA**

9. **MATTERS TO BE CONSIDERED**

9.1 Request to Alter a Heritage Designated Property at 271 Queen Street South (Ward 11)

10. **INFORMATION ITEMS**

11. **OTHER BUSINESS**

12. **DATE OF NEXT MEETING**

March 18, 2025 at 9:30 AM

13. **ADJOURNMENT**

---

## Heritage Advisory Committee

**Date:** January 14, 2025  
**Time:** 9:32 AM  
**Location:** Online Video Conference

Members Present	Councillor Brad Butt	Ward 11 (Chair)
	Councillor Stephen Dasko	Ward 1
	Councillor Dipika Damerla	Ward 7
	Jason DeBrum	Citizen Member
	Alexander Hardy	Citizen Member
	James Holmes	Citizen Member
	Antoine Musiol	Citizen Member
	Somayyeh Nezhad Bagher	Citizen Member
	Jahnvi Pathak	Citizen Member
	Matthew Wilkinson	Citizen Member
Lucy Zita	Citizen Member	
Members Absent	David Cook	Citizen Member (Vice-Chair)
	Terry Ward	Citizen Member

---

### Staff Present

John Dunlop, Manager, Indigenous Relations, Heritage and Museums  
Paula Wubbenhorst, Heritage Planner, Indigenous Relations, Heritage and Museums  
Andrew Douglas, Heritage Analyst, Indigenous Relations, Heritage and Museums  
Martha Cameron, Legislative Coordinator

1. CALL TO ORDER

Councillor Brad Butt, Chair called the meeting to order at 9:32 AM and introduced the new members to the Heritage Advisory Committee: Jason De Brum, Jahnvi Pathak and Somayyeh Nezhad Bagher.

2. INDIGENOUS LAND STATEMENT

Councillor Brad Butt, Chair recited the Indigenous Land Statement.

3. APPROVAL OF AGENDA

Approved (A. Hardy)

4. DECLARATION OF CONFLICT OF INTEREST - Nil

5. MINUTES OF PREVIOUS MEETING

5.1 Draft Heritage Advisory Committee minutes - November 12, 2024

Approved (J. Holmes)

5.2 Draft Heritage Advisory Committee Minutes - December 3, 2024

Approved (M. Wilkinson)

6. DEPUTATIONS

There were no deputations.

7. PUBLIC QUESTION PERIOD - 15 Minute Limit

There were no questions registered for public question period.

8. CONSENT AGENDA

There were no items approved on consent.

9. MATTERS CONSIDERED

9.1 Request to Alter a Heritage Designated Property at 40 Stavebank Road (Ward 1)

Councillor Stephen Dasko spoke to the report.

RECOMMENDATION HAC-0001-2024

Moved By Councillor S. Dasko

That the request to alter the heritage designated property at 40 Stavebank Road (Ward 1), as outlined in the Corporate Report dated November 28, 2024 from the Commissioner of Community Services be approved.

Approved

10. INFORMATION ITEMS - Nil11. OTHER BUSINESS

There were no items for Other Business.

12. DATE OF NEXT MEETING

February 11, 2025 at 9:30 A.M

13. ADJOURNMENT - 9:40 AM

(A. Musiol)

DRAFT

City of Mississauga  
**Corporate Report**



<p>Date: January 13, 2025</p> <p>To: Chair and Members of Heritage Advisory Committee</p> <p>From: Jodi Robillos, Commissioner of Community Services</p>	<p>Originator's files:</p>
	<p>Meeting date: February 11, 2025</p>

## Subject

**Request to Alter a Heritage Designated Property at 271 Queen Street South (Ward 11)**

## Recommendation

That the request to alter the heritage designated property at 271 Queen Street South (Ward 11), as outlined in the Corporate Report dated January 13, 2025, from the Commissioner of Community Services be approved.

## Executive Summary

- The subject property is designated under Part IV of the Ontario Heritage Act and is part of the Streetsville Heritage Conservation District.
- Properties designated under the Ontario Heritage Act require Council permission to alter the property.
- Proposal to install a sign and lighting above the front entrance is in compliance with the HCD Plan and should be approved.

## Background

Council designated 271 Queen Street South under Part IV of the Ontario Heritage Act (OHA) on February 28, 1983 and it is located within the Streetsville Heritage Conservation District. Under the HCD plan, signs require a heritage permit prior to installation.

## Comments

The property owner proposes to install a sign and lighting above the front entrance. The sign will be mounted to the brickwork and be externally lit by two lights positioned above the sign. (see Appendix 1). The sign will be mounted using screws into the mortar in between the bricks to reduce the impact on the building. As the sign will have a minimal impact to the heritage character of the site, staff recommend the approval of this work.

## Financial Impact

There are no financial implications resulting from the recommendation of this report.

## Conclusion

The property owner has proposed to install a sign and lighting above the front entrance. The proposal will not negatively impact the property, therefore should be approved.

## Attachments

Appendix 1: Detailed Drawings



---

Jodi Robillos, Commissioner of Community Services





Prepared by: Andrew Douglas, Heritage Analyst, Indigenous Relations, Heritage & Museums



x1

North Side Front Entrance



CUSTOMER: QAMARIA YEMENI COFFEE	CONTACT: Mohd	REVISION #: 1-2of3	 www.cpsign.com	#6 - 5151 Everest Dr. Mississauga, ON L4W 2Z3
ORDER #: 20/11/2024	PHONE: 416.837.7050	SITE ADDRESS:		
DATE:	EMAIL:	271 Queen St. South, Mississauga, ON		
   	REP: Mohd	CHECKED BY:		
	DESIGNER:			

**TYPICAL DETAILS & CONNECTIONS**

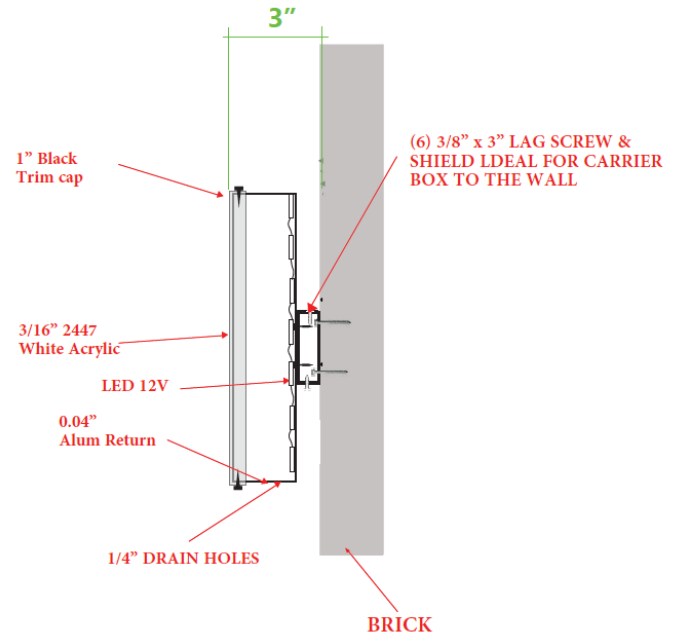
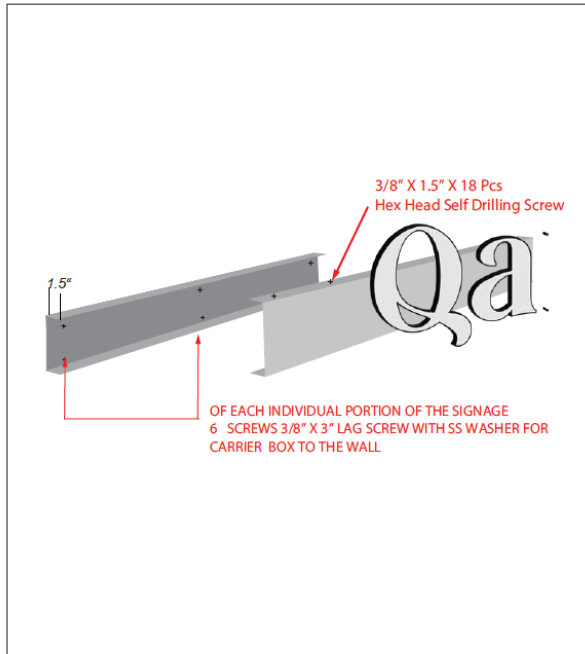

CUSTOMER: QAMARIA YEMENI COFFEE	CONTACT: Mohd	REVISION # 1-2of3
ORDER #	PHONE: 416.837.7050	SITE ADDRESS:
DATE: 20/11/2024	EMAIL: mohd_sk@hotmail.com	271 Queen St. South, Mississauga, ON
	REP: Mohd	CHECKED BY:
	DESIGNER:	

#6 - 5151 Everest Dr.  
Mississauga, ON  
L4W 2Z3