

x1

North Side Front Entrance



CUSTOMER: QAMARIA YEMENI COFFEE	CONTACT: Mohd	REVISION # 1-2of3	 www.cpsign.com	#6 - 5151 Everest Dr. Mississauga, ON L4W 2Z3
ORDER #	PHONE: 416.837.7050	SITE ADDRESS:		
DATE: 20/11/2024	EMAIL:	271 Queen St. South, Mississauga, ON		
	REP: Mohd	CHECKED BY:		
	DESIGNER:			



TYPICAL DETAILS & CONNECTIONS

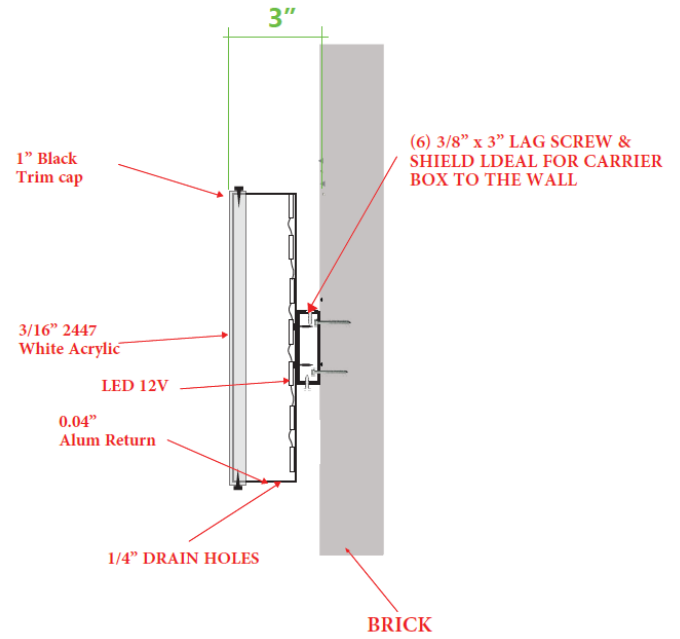
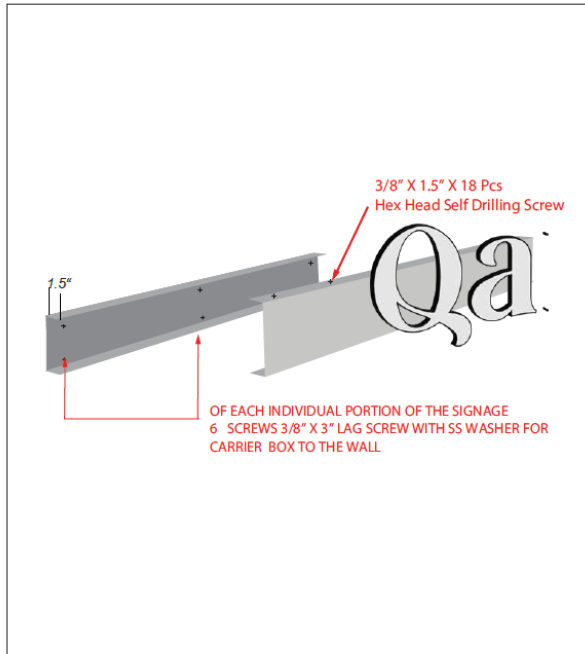

CUSTOMER: QAMARIA YEMENI COFFEE	CONTACT: Mohd	REVISION # 1-2of3
ORDER #	PHONE: 416.837.7050	SITE ADDRESS:
DATE: 20/11/2024	EMAIL: mohd_sk@hotmail.com	271 Queen St. South, Mississauga, ON
	REP: Mohd	
	DESIGNER:	CHECKED BY:



#6 - 5151 Everest Dr.
Mississauga, ON
L4W 2Z3