

# FADS v2.0

## Mississauga Facility Accessibility Design Standards



**Future-Ready,  
Inclusive by Design**



**MISSISSAUGA**

**2025**

# FADS Table of Contents

|   |     |
|---|-----|
| 1.1 Introduction .....                                    | 4   |
| 1.2 Universal Design Principles .....                     | 5   |
| 1.3 Scope .....   | 6   |
| 1.4 Regulatory Framework.....                             | 8   |
| 1.5 Guideline Organization .....                          | 9   |
| 2.1 Space and Reach Requirements .....                    | 10  |
| 2.2 Ground and Floor Surfaces.....                        | 15  |
| 2.3 Ramps.....  | 20  |
| 2.4 Stairs .....  | 29  |
| 2.5 Handrails .....                                       | 36  |
| 2.6 Overhanging and Protruding Objects.....               | 41  |
| 2.7 Rest Areas .....                                      | 44  |
| 2.8 Tactile Walking Surface Indicators.....               | 47  |
| 2.9 Tactile Direction Indicators.....                     | 51  |
| 2.10 Drinking Fountains and Bottle Filling Stations ..... | 55  |
| 2.11 Seating, Tables and Work Surfaces .....              | 59  |
| 3.1 Entrances.....  | 63  |
| 3.2 Doors and Doorways .....                              | 66  |
| 3.3 Interior Accessible Routes .....                      | 77  |
| 3.4 Millwork, Storage and Shelving.....                   | 84  |
| 3.5 Windows and Glazing .....                             | 86  |
| 3.6 Elevating Devices .....                               | 89  |
| 3.7 Service Counters .....                                | 100 |
| 3.8 Washrooms.....  | 104 |
| 3.9 Showers .....   | 120 |
| 3.10 Change Rooms.....                                    | 127 |
| 4.1 Parking and Passenger Loading Zones .....             | 135 |
| 4.2 Accessible Paths of Travel.....                       | 152 |
| 4.3 External Recreational Routes .....                    | 161 |
| 4.4 Curb Ramps and Depressed Curbs.....                   | 169 |
| 4.5 Pedestrian Crossings and Signals .....                | 177 |

|   |     |
|---|-----|
| 4.6 Pedestrian Bridges and Underpasses .....      | 181 |
| 4.7 Street Furniture .....                        | 184 |
| 5.1 Controls and Operating Mechanisms.....        | 191 |
| 5.2 Assistive Listening Devices.....              | 196 |
| 5.3 Public Address Systems .....                  | 200 |
| 5.4 Accessible Public Telephones .....            | 202 |
| 5.5 Acoustics.....                                | 208 |
| 5.6 Security Systems .....                        | 211 |
| 5.7 Fire and Life Safety Systems .....            | 215 |
| 5.8 Lighting .....                                | 220 |
| 5.9 Signage and Wayfinding .....                  | 225 |
| 5.10 Self-service Kiosks.....                     | 236 |
| 6.1 Offices, Work Areas and Meeting Rooms .....   | 241 |
| 6.2 Recreational and Community Facilities.....    | 245 |
| 6.3 Libraries .....                               | 257 |
| 6.4 Cafeteria and Dining Facilities .....         | 264 |
| 6.5 Kitchens and Kitchenettes .....               | 267 |
| 6.6 Waiting and Queuing Areas .....               | 276 |
| 6.7 Balconies, Porches, Terraces and Patios ..... | 281 |
| 6.8 Wellness Rooms .....                          | 284 |
| 6.9 Cultural Art Facilities .....                 | 287 |
| 6.10 Accessible Playgrounds.....                  | 291 |
| 6.11 Lockers and Baggage Storage .....            | 296 |
| 6.12 Fire Stations.....                           | 301 |
| 6.13 Municipal Courts .....                       | 304 |

## 1.1 Introduction

Accessibility and inclusion are essential to building communities where everyone can participate fully. In Ontario, over **28% of people live with a disability**, which equates to more than 201,000 Mississauga residents. It is expected that this number will continue to rise given the aging population. Barriers in the built environment affect not only persons with disabilities but also seniors, parents with strollers, newcomers and people with temporary injuries.

Designing accessible facilities benefits everyone — creating safe, dignified, and equitable experiences. Inclusive design supports independence, reduces risks and fosters community participation. By embedding accessibility at the earliest stages of planning and design, we can reduce costly retrofits, meet legislative obligations and deliver facilities that serve every resident and visitor.

These standards translate accessibility principles, legislative requirements, and community expectations into practical design guidance for City staff, architects, consultants and contractors. It reflects Mississauga's commitment to creating facilities that are **future-ready, inclusive by design, and resilient over time**.

## 1.2 Universal Design Principles

This manual is guided by the internationally recognized **Seven Principles of Universal Design**. These principles promote environments that are usable by the widest range of people, regardless of age, ability, or circumstance:

- **Equitable Use** – Design is useful and marketable to people with diverse abilities
- **Flexibility in Use** – Accommodates a wide range of preferences and abilities
- **Simple and Intuitive** – Easy to understand, regardless of experience or literacy
- **Perceptible Information** – Communicates effectively through multiple modes (visual, tactile, auditory)
- **Tolerance for Error** – Minimizes hazards and unintended actions
- **Low Physical Effort** – Can be used efficiently and comfortably with minimal fatigue
- **Size and Space for Approach and Use** – Provides adequate room for use regardless of mobility or posture

Embedding these principles ensures spaces remain adaptable, intuitive, and welcoming over time, creating facilities that serve current and future generations equitably.

## 1.3 Scope

These standards apply to all newly constructed, renovated or leased municipal facilities that are accessible to the public, staff or visitors. They cover both interior and exterior environments, including entrances, circulation routes, service areas, amenities and specialized facilities.

The requirements are intended to go beyond minimum legislative obligations, reflecting best practices in universal and inclusive design. Where technical infeasibility exists in existing buildings, the intent of the requirements should guide design decisions, with the goal of reducing barriers to the greatest extent possible.

Exceptions are limited to areas exclusively for firefighters or other staff-only operational use, as noted in relevant chapters.

### Exceptions and Equivalent Facilitation

In limited or special circumstances, strict compliance with these Standards may be technically infeasible or result in disproportionate cost or operational risk. In such cases, an exception may be approved only where all of the following conditions are met:

1. **Approval and Accountability**
  - a) Written approval by both the **Director, Facilities & Property Management (FPM)** and the **Manager, Accessibility Planning** is required before proceeding
2. **Documented Rationale**
  - a) A concise statement identifying the constraint (e.g., structural or heritage limitations, utility conflicts, life-safety or emergency-response constraints, or site limitations)
  - b) A brief cost/feasibility summary demonstrating why full compliance is not practicable at this time
3. **Equivalent Facilitation**
  - a) The design must incorporate alternative measures that achieve a substantially equivalent or greater level of accessibility for the same users (for example, alternative routes, technologies, or programmatic supports)
  - b) Where temporary solutions are used, they must include a clear timeline for achieving permanent compliance or improvement (where possible)
4. **Consultation and Record Keeping**
  - a) Accessibility Planning must be consulted to assess user impact and options

- b) Each approved exception must be recorded in a FADS Exception Log, including the rationale and any mitigation measures, to ensure transparency and accountability

## Notes

- This clause does not permit wholesale non-compliance. It is intended for special circumstances where constraints can be demonstrated and mitigations provide an equivalent outcome
- For heritage sites, design solutions should balance heritage preservation with maximum achievable accessibility

## 1.4 Regulatory Framework

This manual is informed by, and complements, the following legislation and standards:

- **Accessibility for Ontarians with Disabilities Act (AODA)** and the Integrated Accessibility Standards Regulation (IASR)
- **Ontario Human Rights Code**, which protects against discrimination on the basis of disability
- **Ontario Building Code (OBC)**, which establishes minimum accessibility requirements in construction
- **CSA B651: Accessible Design for the Built Environment** and other applicable CSA standards, which provides technical guidance on accessible design features
- Relevant municipal by-laws, policies, and strategies

Where there is conflict between these standards and other legislation or standards, the most stringent requirement shall apply.

## 1.5 Guideline Organization

The manual is organized into thematic sections for ease of use:

- **Common Elements** – core accessibility requirements that apply broadly to most facilities
- **Interior and Exterior Environments** – requirements specific to internal circulation and external site design
- **Systems and Controls** – communication, wayfinding, lighting, alarms and related infrastructure
- **Special Facilities and Spaces** – requirements for specific facility types (e.g., libraries, courts, fire stations)

Each section includes:

- **Rationale** – why the requirement matters
- **Application** – when and where it applies
- **Design Requirements** – measurable, enforceable standards with dimensions, layout and operability
- **Figures and At-a-Glance Tables** – visual and summary tools to aid understanding and compliance
- **Supplementary Resources & References** – accessibility and code references

## 2.1 Space and Reach Requirements

These guidelines define minimum space requirements for accessibility, ensuring mobility devices can navigate public spaces effectively. These dimensions support the planning and construction of accessible environments that meet the needs of people of all abilities.

### Floor Space Requirements

A clear floor space is essential for the maneuverability of mobility devices. The following dimensions are based on the universal size needed to accommodate 95% of mobility devices in North America:

- 900 mm wide by 1500 mm long minimum for a front approach (See Figure 1)
- 900 mm wide by 2200 mm long minimum for a side approach (See Figure 2)

Unless specified otherwise, a clear floor space must be provided in areas where access is required to:

- Wall-mounted controls
- Power door operators
- Tactile signage
- Service counters
- Workstations
- Under tabletops, lavatories, sinks, or drinking fountains

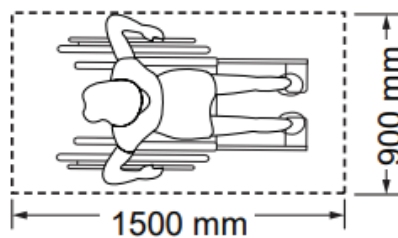

**Figure 1: Clear Floor Space for a Front Approach**

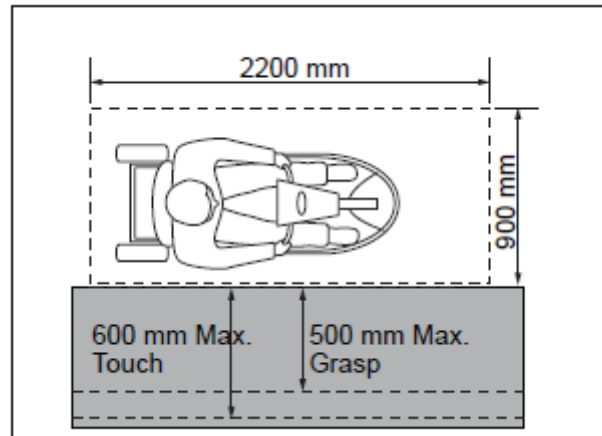

Figure 2: Clear Floor Space for a Side Approach

### Clear Turning Space

To allow individuals in mobility devices to make a 360-degree turn, a clear floor space of **2500 mm in diameter** is required. This dimension is considered the universal size needed to accommodate 95% of mobility devices in North America and ensures users can move around obstacles safely and independently (See Figure 3).

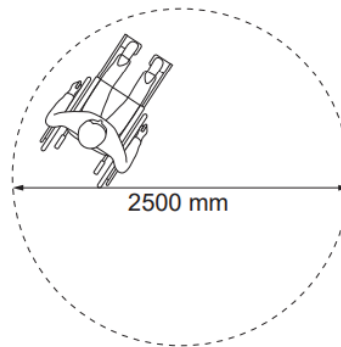

Figure 3: Clear Turning Space

### Knee and Toe Clearance

For a front approach to workstations, counters or any tabletop, knee and toe space must be provided:

- 735 mm minimum height from the floor
- 500 mm minimum depth at the front
- 900 mm minimum width

This clearance ensures that individuals using wheelchairs or scooters can access and use the surface comfortably.

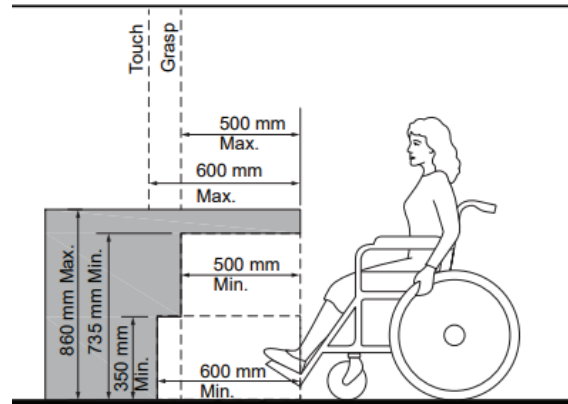
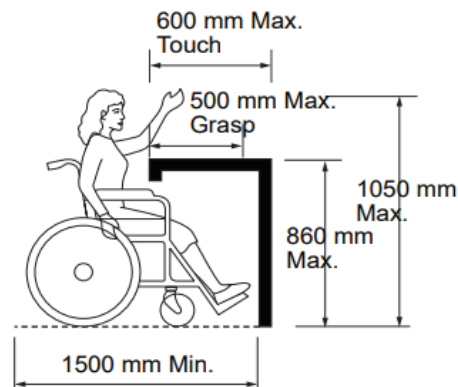

**Figure 4: Knee and Toe Clearance**

## Reach Range

The reach range for objects or items should be between 460 mm and 1050 mm A.F.F.

- For obstructed surfaces (such as an object's top surface between 860 mm to 1050 mm), a reach range of 600 mm maximum depth is necessary for both front and side approaches. This ensures individuals can reach items without obstruction



**Figure 5: Reach Range to Touch**

## Side Approach Clearance

- For a side approach, which allows mobility devices to approach parallel to an object, the clear floor space must be 900 mm by 2200 mm. This allows users to approach objects without interference from other items or structures

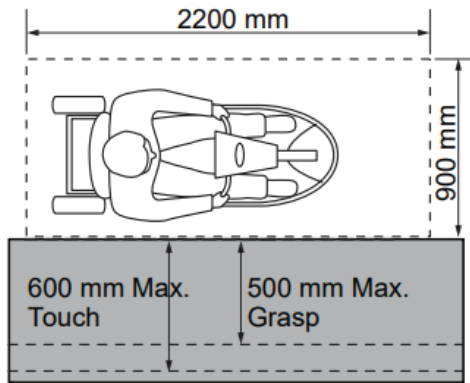

Figure 6: Clear Floor Space for a Side Approach

### Reach Range to Grasp

- The reach range for grasping an object should be between 460 mm and 1050 mm AFF
- If the item has an obstruction between 860 mm to 1050 mm, the reach depth must not exceed 500 mm, ensuring accessibility from both the front and side

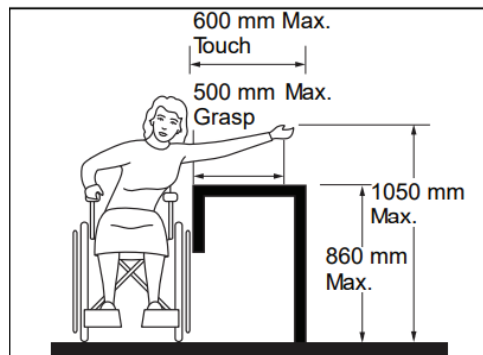

Figure 7: Reach Range to Grasp

Table 1: Space and Reach Requirements at a Glance

| Feature  | Minimum / Recommended Dimensions   | Notes / Key Requirements  |
|--|--|---|
| <p><b>Clear Floor Space – Front Approach</b></p> | <ul style="list-style-type: none"> <li>• 900 mm wide × 1500 mm long</li> </ul> | <ul style="list-style-type: none"> <li>• Required at:                             <ul style="list-style-type: none"> <li>○ Wall-mounted controls</li> <li>○ Power door operators</li> <li>○ Tactile signage</li> <li>○ Service counters</li> <li>○ Workstations</li> <li>○ Under tables</li> <li>○ Lavatories</li> <li>○ Sinks</li> </ul> </li> </ul> |

| Feature                                  | Minimum / Recommended Dimensions  | Notes / Key Requirements  |
|--|---|---|
|  |   | <ul style="list-style-type: none"> <li>○ Drinking fountains</li> </ul>  |
| <b>Clear Floor Space – Side Approach</b> | <ul style="list-style-type: none"> <li>• 900 mm wide × 2200 mm long</li> </ul>  | <ul style="list-style-type: none"> <li>• Same applications as front approach</li> <li>• Allows parallel positioning of mobility devices</li> </ul>  |
| <b>Turning Space</b>                     | <ul style="list-style-type: none"> <li>• 2500 mm diameter</li> </ul>  | <ul style="list-style-type: none"> <li>• Required for 360° turns</li> <li>• Accommodates 95% of mobility devices</li> </ul>   |
| <b>Knee and Toe Clearance</b>            | <ul style="list-style-type: none"> <li>• 735 mm height × 500 mm depth × 900 mm width</li> </ul>                       | <ul style="list-style-type: none"> <li>• Required at: <ul style="list-style-type: none"> <li>○ Workstations</li> <li>○ Counters</li> <li>○ Tables</li> <li>○ Sinks</li> <li>○ Lavatories</li> </ul> </li> </ul> |
| <b>Reach Range – Unobstructed</b>        | <ul style="list-style-type: none"> <li>• 460–1050 mm AFF</li> </ul>   | <ul style="list-style-type: none"> <li>• Comfortable vertical reach for seated/standing users</li> </ul>  |
| <b>Reach Range – Obstructed</b>          | <ul style="list-style-type: none"> <li>• Top surface 860–1050 mm AFF</li> <li>• Depth ≤600 mm (front/side)</li> </ul> | <ul style="list-style-type: none"> <li>• Ensures users can reach over obstructions</li> </ul>   |
| <b>Reach Range – Grasp</b>               | <ul style="list-style-type: none"> <li>• 460–1050 mm AFF</li> <li>• Obstruction depth ≤500 mm</li> </ul>              | <ul style="list-style-type: none"> <li>• For operable parts (e.g., switches, handles, controls)</li> </ul>  |
| <b>Side Approach Clearance</b>           | <ul style="list-style-type: none"> <li>• 900 mm wide × 2200 mm long</li> </ul>  | <ul style="list-style-type: none"> <li>• Parallel approach clearances for mobility devices</li> </ul>   |

## 2.2 Ground and Floor Surfaces

### Rationale

The design of ground and floor surfaces affects the accessibility and safety of all individuals. Irregular surfaces, like cobblestones or pea-gravel concrete, create barriers, making walking and wheelchair navigation difficult. Smooth, stable, and level surfaces are essential for ease of movement, especially for individuals using mobility aids.

Slippery surfaces are hazardous for seniors and individuals with mobility or balance challenges. Non-slip materials reduce the risk of falls and improve safety. Similarly, glare from highly reflective surfaces can obscure important features, especially for those with low or no vision.

Using clear color contrast between walls and floors enhances spatial awareness for individuals with vision loss. Changes in floor color or texture signal transitions, such as changes in level or function, and aid navigation. Thoughtfully designed floors with varying materials, textures, and colors further support accessibility by signaling spaces like entrances or seating areas.

Contrasting colors define routes and boundaries, while tactile indicators like raised patterns alert users to changes in level or hazards. These elements should be simple to avoid overwhelming users, enhancing accessibility without distraction.

### Application

Accessible ground and floor surface design, including the strategic use of materials, textures, and colors, should be implemented throughout all areas of a building to ensure safety and inclusivity. This is particularly important in high-traffic areas such as entrances, corridors, and common spaces, as well as in transitional zones like ramps, stairs, and elevator lobbies. In exhibition spaces, museums, and galleries, contrasting textures and colors help identify pathways and display areas. Public facilities like libraries and transit stations also benefit from tactile guidance and color contrasts. Outdoor areas like walkways and parking lots should include slip-resistant surfaces and tactile guidance to ensure safe access.

### Design Requirements

#### Surface

Ground and floor surfaces must:

- Be firm, stable and slip-resistant
- Have joints between surfaces no wider than 13 mm (maximum) or 6 mm (preferred) See Figure 1
- Have finishes and materials that have high visual colour/tonal contrast (minimum 70%) or a change in texture with surrounding surfaces:
  - At curb ramps and depressed curbs

- Adjacent wall surfaces or their baseboards
- At changes in level (e.g., stairs and ramps)
- At obstacles
- For tactile walking surface indicators
- Not be heavily patterned
- Have a vertical change in level of less than 6 mm
- Step-free Access: Where feasible, provide ramps with a slope no greater than 1:20 (5%) and a minimum width of 1200 mm
  - Any ramp that exceeds maximum slope must be reviewed by the Accessibility Planning Team and the AAC's FADS Subcommittee
- Install tactile indicators at stairs, ramps, and key navigation points, with a minimum width of 600 mm. See Section 2.8 Tactile Indicators

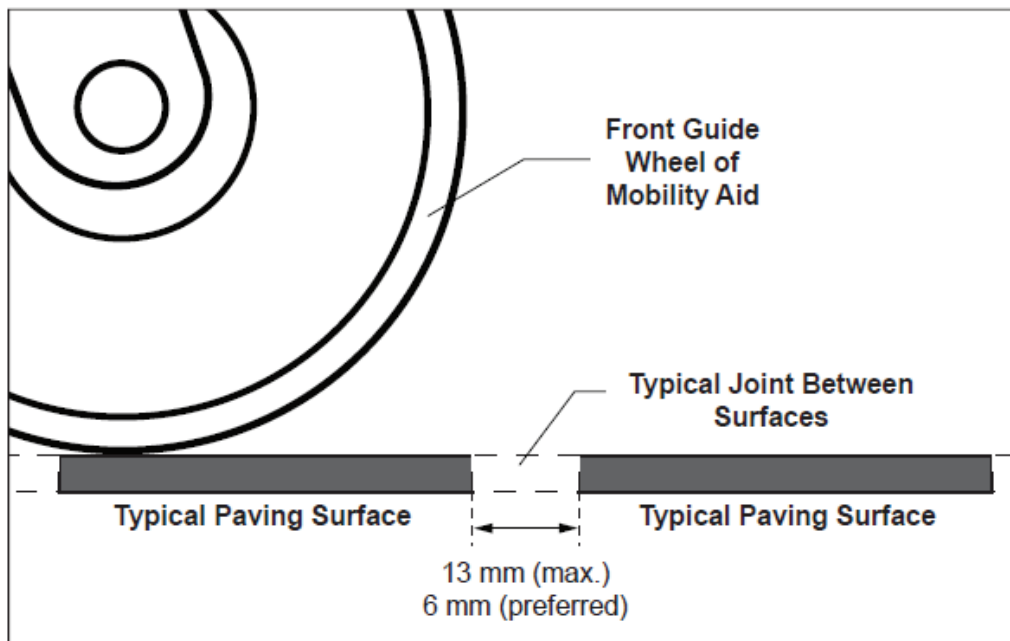

**Figure 8: Joints between surfaces – section view**

## **Carpets**

Carpets must:

- Be securely fixed to the floor
- Be a max height of 13 mm
- Have firm under padding or backing to reduce rolling resistance for wheeled mobility aids
- Have a firm, low level loop or level cut or uncut pile

## Floor Mats

Floor mats must:

- Be securely fixed or placed in a depression that is level with surrounding floor area
- Have a maximum height of 13 mm high with beveled edges
- Have a colour contrast of 70% (minimum) between floor mats or grilles and surrounding surfaces

## Gratings and Covers

Gratings and floor drains must:

- Be max 13 mm wide
- Have openings in one direction and perpendicular to the dominant direction of travel

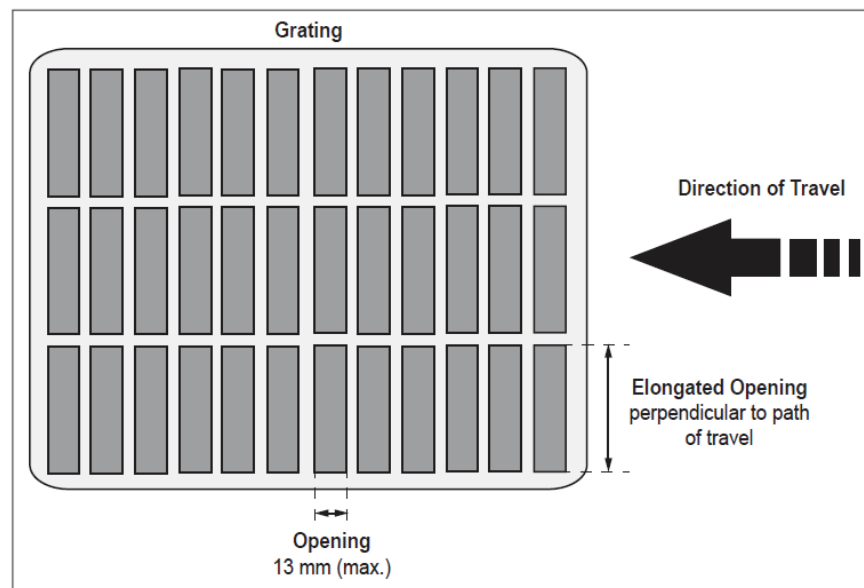

**Figure 9: Grating Opening – Plan View**

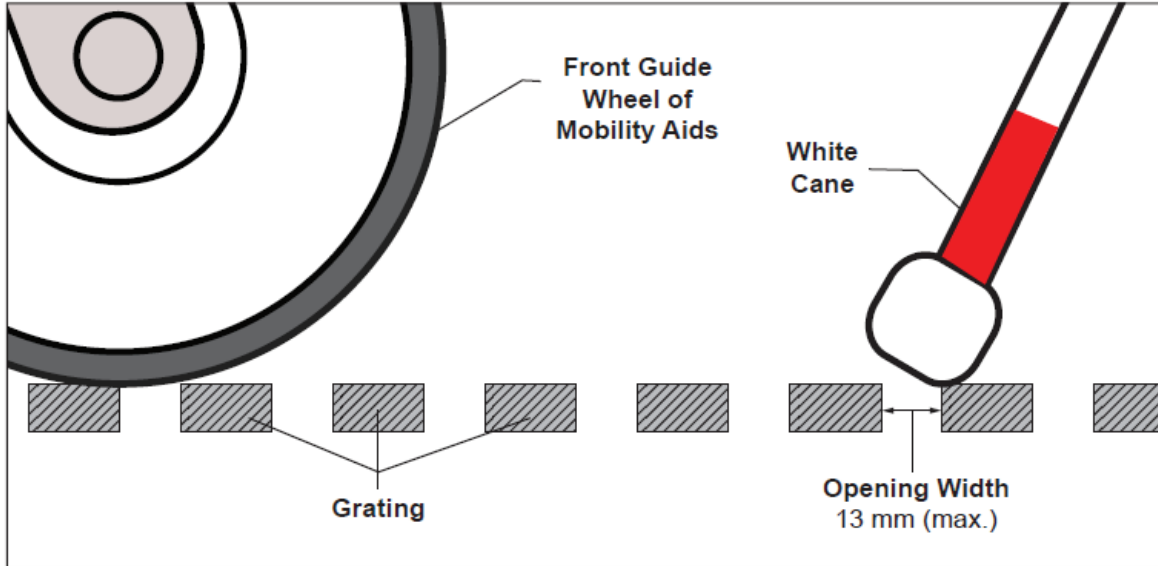

Figure 10: Gratings – Section View

### Wayfinding Support

- Contrasting Materials: Define pathways with contrasting colors and materials at least 1500 mm wide for clear identification
- Tactile and Textured Indicators: Include raised strips or textured pathways with a standard height of 4–5 mm for visually impaired users
- Pathway Boundaries: Install barriers or contrasting edge strips at least 50 mm wide to mark walking zones

Table 2: Ground and Floor Surfaces at a Glance

| Feature                            | Minimum / Recommended Dimensions | Notes / Key Requirements  |
|------------------------------------|----------------------------------|---|
| Surface – Firmness                 | • N/A                            | • Must be firm, stable, and slip-resistant  |
| Surface – Joints                   | • ≤13 mm (6 mm preferred)        | • Applies to joints between surfaces; see Figure 8  |
| Surface – Visual Contrast          | • ≥70%                           | • Or change in texture at curbs, wall bases, level changes, obstacles, tactile walking surface indicators |
| Surface – Vertical Change in Level | • <6 mm                          | • Step-free access preferred  |

| Feature                                   | Minimum / Recommended Dimensions  | Notes / Key Requirements  |
|---|---|---|
| <b>Ramps (Step-Free Access)</b>           | <ul style="list-style-type: none"> <li>Slope <math>\leq 1:20</math> (5%);</li> <li>Width <math>\geq 1200</math> mm</li> </ul> | <ul style="list-style-type: none"> <li>Slopes exceeding max require review by Accessibility Planning + AAC FADS Subcommittee</li> </ul>               |
| <b>Tactile Walking Surface Indicators</b> | <ul style="list-style-type: none"> <li><math>\geq 600</math> mm wide</li> </ul>   | <ul style="list-style-type: none"> <li>Required at stairs, ramps, and navigation points; see Section XYZ</li> </ul>                                   |
| <b>Surface Patterning</b>                 | <ul style="list-style-type: none"> <li>N/A</li> </ul>   | <ul style="list-style-type: none"> <li>Avoid heavily patterned finishes</li> </ul>  |
| <b>Carpets – Height</b>                   | <ul style="list-style-type: none"> <li><math>\leq 13</math> mm</li> </ul>   | <ul style="list-style-type: none"> <li>Must be securely fixed; firm underpadding; low-level loop, cut, or uncut pile</li> </ul>                       |
| <b>Floor Mats – Height</b>                | <ul style="list-style-type: none"> <li><math>\leq 13</math> mm</li> </ul>   | <ul style="list-style-type: none"> <li>Securely fixed or recessed; beveled edges; <math>\geq 70\%</math> colour contrast with surroundings</li> </ul> |
| <b>Gratings and Covers – Width</b>        | <ul style="list-style-type: none"> <li><math>\leq 13</math> mm openings</li> </ul>  | <ul style="list-style-type: none"> <li>Openings perpendicular to dominant travel direction; see Figures 9a, 9b</li> </ul>                             |
| <b>Wayfinding – Contrasting Materials</b> | <ul style="list-style-type: none"> <li>Pathways <math>\geq 1500</math> mm wide</li> </ul>                                     | <ul style="list-style-type: none"> <li>Use colour/material contrast for clear identification</li> </ul>   |
| <b>Wayfinding – Tactile Strips</b>        | <ul style="list-style-type: none"> <li>4–5 mm height</li> </ul>   | <ul style="list-style-type: none"> <li>Raised strips or textured pathways for visually impaired users</li> </ul>                                      |
| <b>Wayfinding – Edge Boundaries</b>       | <ul style="list-style-type: none"> <li><math>\geq 50</math> mm wide</li> </ul>  | <ul style="list-style-type: none"> <li>Contrasting edge strips or barriers to mark walking zones</li> </ul>   |

## 2.3 Ramps

### Rationale

Ramps provide crucial access for individuals using wheelchairs, scooters, strollers, or trolleys. However, poorly designed ramps can create accessibility challenges and safety hazards. Steep slopes, cross slopes, and inadequate space for maneuvering can make ramps difficult to navigate and pose risks for tipping or losing control. Properly designed ramps with manageable gradients, level resting areas, and safety features ensure usability for everyone.

When ramps are necessary due to a change in level, thoughtful design ensures accessibility and safety. Features such as textured surfaces, edge protection, handrails, and heated surfaces for snow and ice removal are essential for providing a safe, functional ramp. It is also important to note that ramps may not be suitable for all users, particularly those using walking aids like rollators, who may have difficulty maintaining balance on an incline.

### Application

Any accessible route with a slope steeper than 1:20 (5%) shall be considered a ramp and must comply with this section.

### Design Requirements

#### General Principles

- Ramps should provide equitable, safe and independent access for all users, minimizing fatigue and supporting dignity
- Ramps are preferred over lifts where feasible, as they are more reliable and intuitive to use
- At slope transitions, ramps must have a 40-60 mm wide colour-contrasted strip across the width of the ramp, located on the sloped surface
- Designated areas for snow piling must be provided at exterior ramps, located away from pedestrian routes

#### Running Slope and Cross Slope

- Preferred slope: 1:20 (5%) — optimal for universal access.
- Maximum slope (new construction): 1:15 (6.7%).
- Retrofit allowance: up to 1:12 (8.3%) only where technically infeasible
  - Subject to approval of the Director of Facilities & Property Management
- Cross slope: not more than 1:50 (2%)

## Ramp Widths

- Minimum clear width between handrails: 1100 mm
- Retrofit allowance: may be reduced to 900 mm where technically infeasible

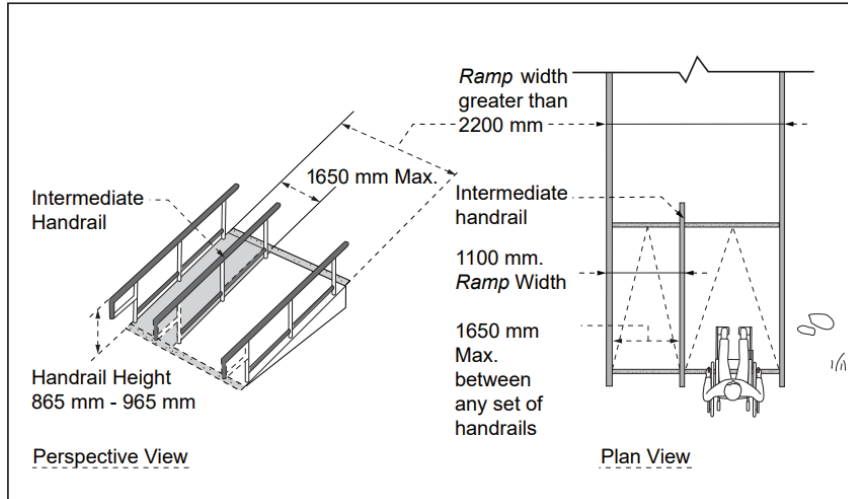

**Figure 11: Ramp Width and Handrail**

## Landings

Landings must:

- Level landings required at top, bottom, and every 9 m of run
- Minimum landing length: 1670 mm; width equal to the widest connecting ramp
- Doors must not swing into landings
- Intermediate landings must be at least as wide as the ramp run that leads to them

**Table 4: Landing Types and Dimensions**

| Type          | Change of direction                    | Minimum Width (in mm)     | Minimum Length (in mm) | Retrofit minimum (in mm)    |
|---------------|--|---------------------------|------------------------|-----------------------------|
| Top or bottom | Not applicable                         | 2440                      | 2440                   | Width: 1670<br>Length: 1670 |
| Intermediate  | No change                              | Widest ramp leading to it | 1670                   |                             |
| Intermediate  | U-shaped                               | 2440                      | 1670                   | Width: 2120                 |
| Intermediate  | 90° or more in the direction of travel | Width of the ramp         | 1670                   |                             |

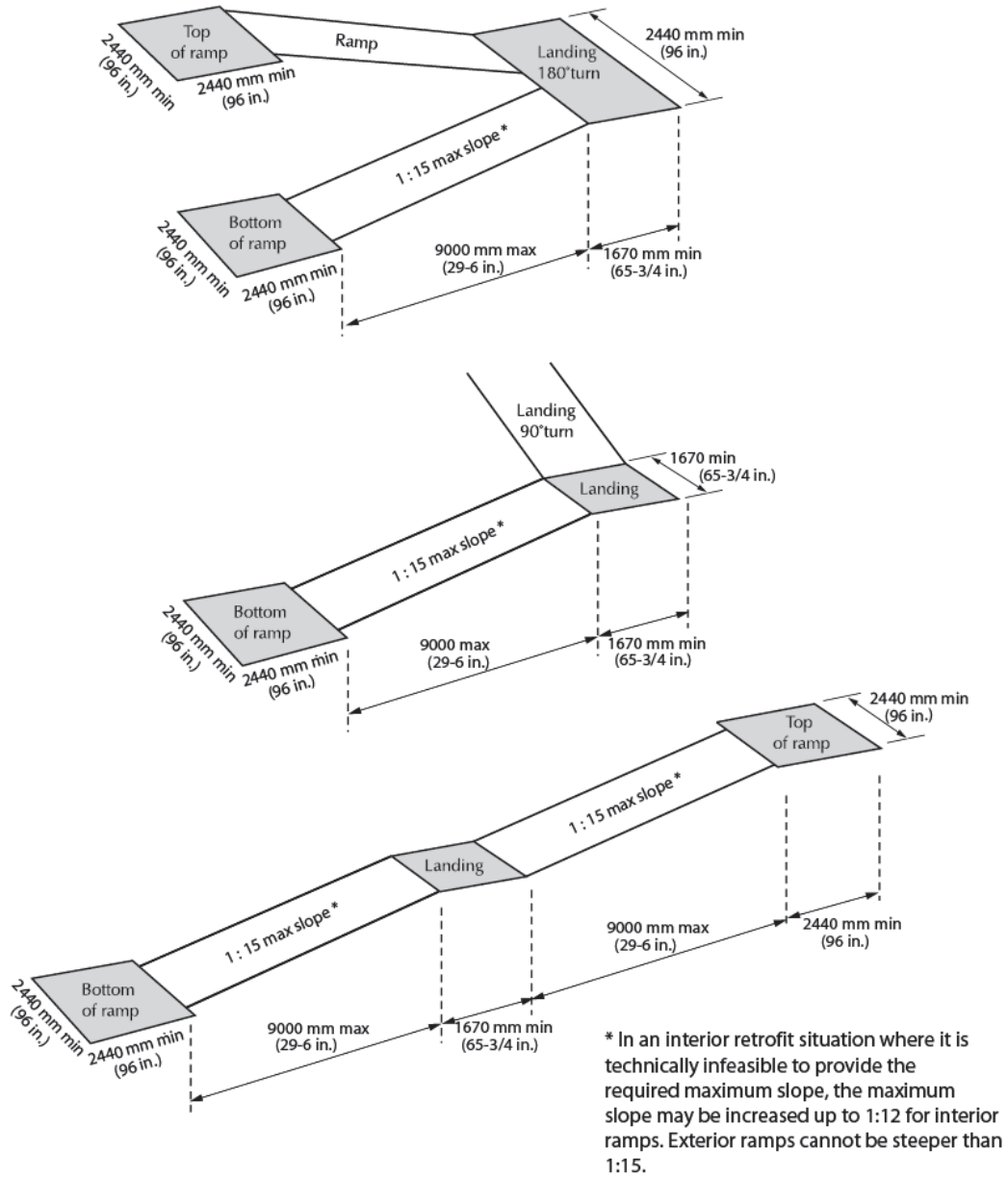
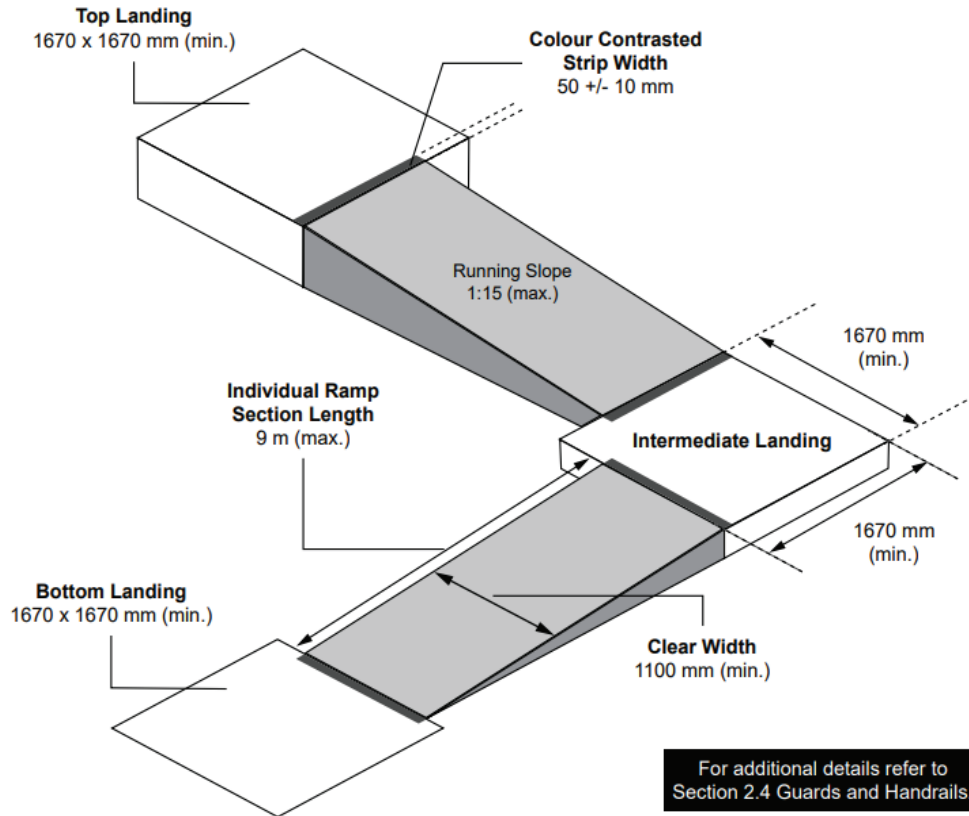

Figure 12: Minimum Ramp Landing Dimensions



**Figure 13: Minimum Ramp Landing Dimensions**

## Handrails and Guards

- Handrails required on both sides (see Section 2.5 Handrails)
- Intermediate handrails required where ramp exceeds 2200 mm wide
- Guards: minimum 1070 mm on open sides; curbs 75 mm minimum where no wall/guard is provided
- Edge protection and guards must visually contrast with background

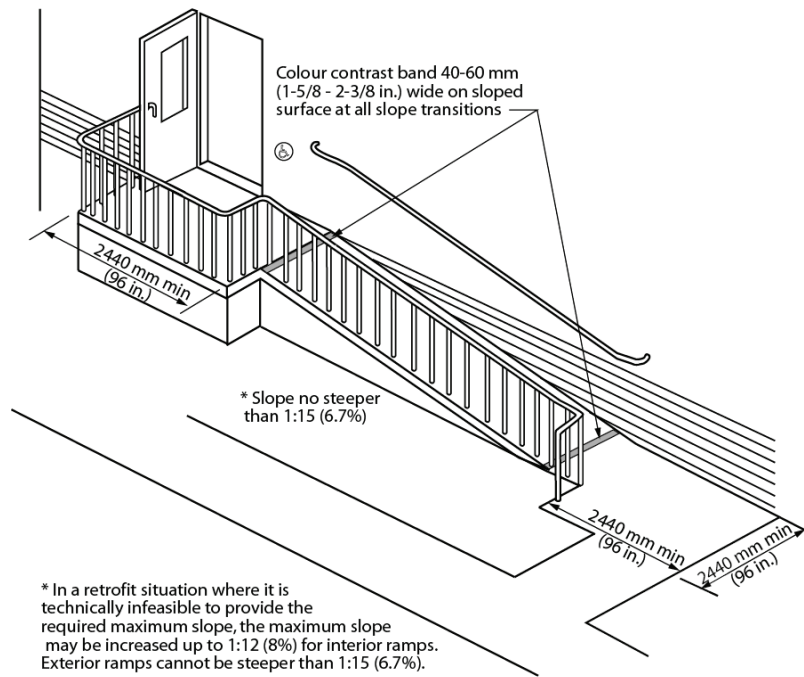

Figure 14: Ramp Criteria

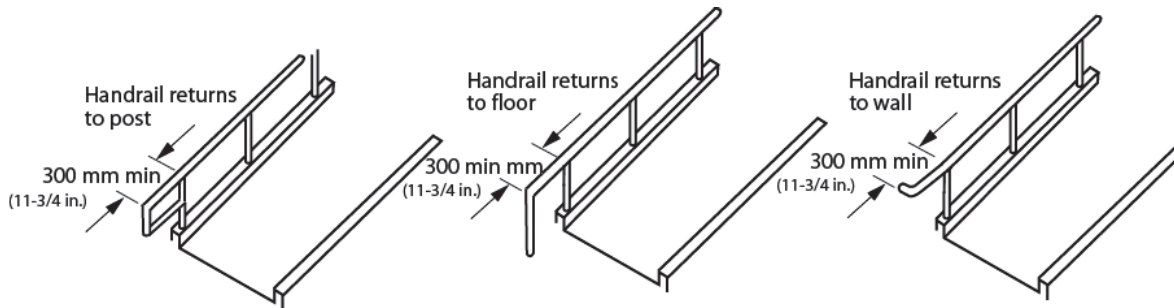

Figure 15: Horizontal Handrail Extensions

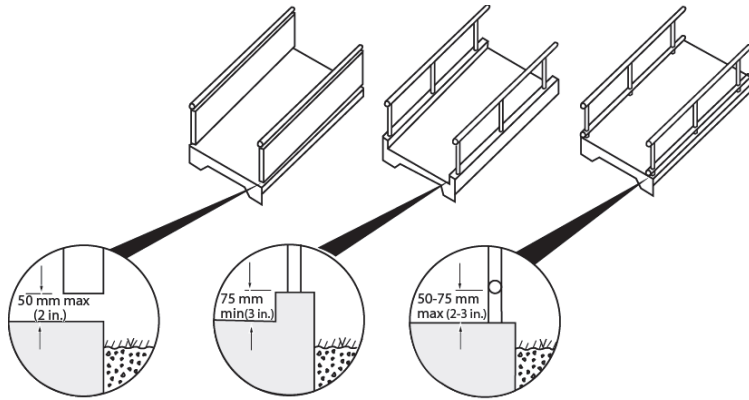

Figure 16: Edge Protection at Ramps

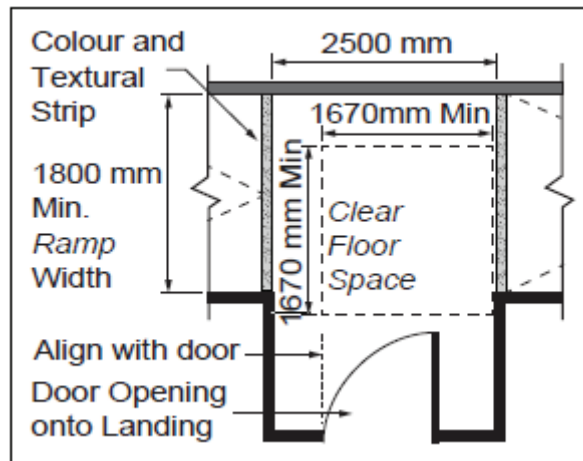

Figure 17: Protection on Ramps

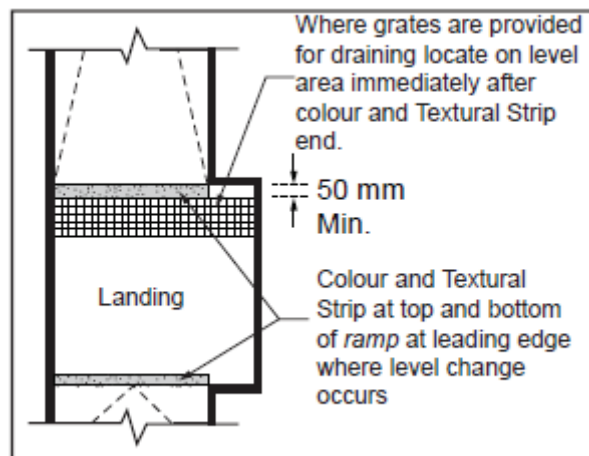
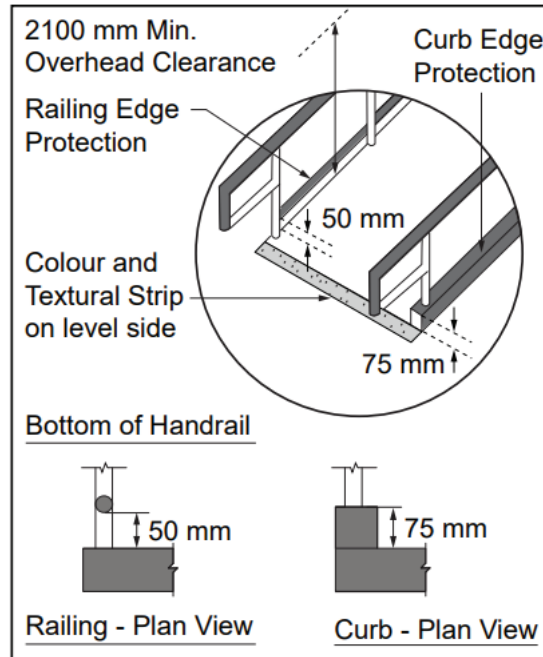

Figure 18: Ramp Grates and Textural Strip



**Figure 19: Protection on Ramps**

## Ramp Surfaces

- Ramp surfaces must be firm, stable and slip-resistant in both wet and dry conditions
- Avoid loose or thick coverings
- Provide visual contrast between ramps and landings
- Where different materials are used for the ramp and landings, frictional properties must be consistent to reduce tripping hazards

## Outdoor Ramps

- Must be drained to prevent pooling or water flow along the ramp
- Drainage grates must be flush with the surface and have openings less than 13 mm, oriented perpendicular to travel
- De-icing provisions must be provided where necessary
- Edge protection should allow for snow removal and water run-off
- Handrails designed for safe grasping in hot or cold weather

## Indoor Ramps

- Should be used for limited level changes and not as the sole means of vertical circulation

Table 6: Ramps at a Glance

| Feature                       | Minimum / Recommended Dimensions  | Notes / Key Requirements  |
|-------------------------------|---|---|
| <b>General Principles</b>     | <ul style="list-style-type: none"> <li>N/A</li> </ul>   | <ul style="list-style-type: none"> <li>Ramps preferred over lifts</li> <li>Colour-contrasted strip 40-60 mm wide at slope transitions</li> <li>Designated snow piling areas required</li> </ul> |
| <b>Running Slope</b>          | <ul style="list-style-type: none"> <li>Preferred: 1:20 (5%)</li> </ul>                        | <ul style="list-style-type: none"> <li>Optimal for universal access</li> </ul>  |
|                               | <ul style="list-style-type: none"> <li>Maximum (new construction): 1:15 (6.7%)</li> </ul>     | <ul style="list-style-type: none"> <li>Steeper not permitted in new builds</li> </ul>   |
|                               | <ul style="list-style-type: none"> <li>Retrofit allowance: 1:12 (8.3%)</li> </ul>             | <ul style="list-style-type: none"> <li>Only if technically infeasible</li> <li>Requires approval by Director of F&amp;PM</li> </ul>   |
| <b>Cross Slope</b>            | <ul style="list-style-type: none"> <li>≤1:50 (2%)</li> </ul>                                  | <ul style="list-style-type: none"> <li>Applies across ramp width</li> </ul>   |
| <b>Width</b>                  | <ul style="list-style-type: none"> <li>≥1100 mm clear between handrails</li> </ul>            | <ul style="list-style-type: none"> <li>Retrofit minimum 900 mm</li> </ul>   |
| <b>Landings – location</b>    | <ul style="list-style-type: none"> <li>At top, bottom and every 9m of run</li> </ul>          | <ul style="list-style-type: none"> <li>Must be level and free of obstructions</li> </ul>  |
| <b>Landings – Dimensions</b>  | <ul style="list-style-type: none"> <li>2440 mm width × 2440 mm length (top/bottom)</li> </ul> | <ul style="list-style-type: none"> <li>Width ≥1500 mm at 180° turns</li> <li>Intermediate landings as wide as ramp run</li> </ul>   |
| <b>Handrails – Height</b>     | <ul style="list-style-type: none"> <li>865–920 mm</li> </ul>                                  | <ul style="list-style-type: none"> <li>Required both sides unless ramp ≤800 mm long</li> </ul>  |
| <b>Handrails – Extension</b>  | <ul style="list-style-type: none"> <li>≥300 mm horizontal beyond ramp</li> </ul>              | <ul style="list-style-type: none"> <li>Must return to wall, floor, or post</li> </ul>   |
| <b>Handrails – Spacing</b>    | <ul style="list-style-type: none"> <li>950–1200 mm between one set</li> </ul>                 | <ul style="list-style-type: none"> <li>Additional sets required for ramps &gt;2200 mm wide</li> </ul>   |
| <b>Guards – Height</b>        | <ul style="list-style-type: none"> <li>≥1070 mm</li> </ul>                                    | <ul style="list-style-type: none"> <li>Must prevent climbing</li> <li>Comply with OBC</li> </ul>  |
| <b>Edge Protection – Curb</b> | <ul style="list-style-type: none"> <li>≥75 mm high</li> </ul>                                 | <ul style="list-style-type: none"> <li>Where no solid enclosure/guard provided</li> </ul>   |

| Feature                           | Minimum / Recommended Dimensions                        | Notes / Key Requirements   |
|-----------------------------------|---|--|
| <b>Edge Protection – Contrast</b> | <ul style="list-style-type: none"> <li>• 70%</li> </ul> | <ul style="list-style-type: none"> <li>• For visibility and orientation</li> </ul>   |
| <b>Surface – Finish</b>           | <ul style="list-style-type: none"> <li>• N/A</li> </ul> | <ul style="list-style-type: none"> <li>• Firm, smooth, slip-resistant (wet/dry)</li> <li>• Avoid thick/loose textiles</li> <li>• Openings <math>\leq 13</math> mm, oriented perpendicular to travel</li> </ul> |
| <b>Surface – Contrast</b>         | <ul style="list-style-type: none"> <li>• N/A</li> </ul> | <ul style="list-style-type: none"> <li>• Ramps must contrast with landings or have full-width markings</li> </ul>  |
| <b>Outdoor Ramps – Drainage</b>   | <ul style="list-style-type: none"> <li>• N/A</li> </ul> | <ul style="list-style-type: none"> <li>• Proper drainage; flush gratings</li> </ul>  |
| <b>Outdoor Ramps – Safety</b>     | <ul style="list-style-type: none"> <li>• N/A</li> </ul> | <ul style="list-style-type: none"> <li>• Provide de-icing</li> <li>• Edge protection open for snow removal</li> </ul>  |
| <b>Indoor Ramps – Use</b>         | <ul style="list-style-type: none"> <li>• N/A</li> </ul> | <ul style="list-style-type: none"> <li>• Should serve only limited level differences</li> <li>• Not sole means of level change</li> </ul>  |

## 2.4 Stairs

### Rationale

Stairs can be challenging for individuals with mobility impairments, including children, seniors, and individuals of shorter stature. Poorly designed stair nosings, uneven risers, and insufficient handrails create tripping hazards, especially for those using mobility aids such as canes or prosthetics. Properly designed stairs with appropriate dimensions, clear markings, and effective handrails promote safe use for all individuals, regardless of their physical abilities.

It is also important to provide clear visual and tactile cues for individuals with vision impairments to indicate the presence of stairs. This ensures safe navigation, particularly for those who rely on tactile or auditory information for orientation.

### Application

Interior and exterior stairs must comply with this section.

- There must be no isolated steps (one or two steps, according to the OBC)
- Flights of steps should be straight or, when necessary, large-diameter curved stairs

In retrofit situations:

- Stairs need not comply if they connect levels accessible by an elevator, ramp, or other accessible means of vertical access
- Dimensional changes to steps and landings are not required, however, all other design requirements must be met

**Note:** Spiral/helical stairs should be avoided, as they are difficult for people with mobility impairment or vision loss to navigate.

### Requirements

#### Flight of Stairs

- Be protected by a wall or guard on both sides
- Uniform riser heights: 125-175 mm (150 mm preferred outdoors)
- Uniform tread depths: 280-355 mm
- No open risers
- The sum of the run and twice the rise of a step must be between 600 mm and 660 mm
- Detectable warning surfaces in compliance with Section 2.8 Tactile Walking Surface Indicators
- Slip-resistant surfaces in both wet and dry conditions

- Snow piling areas provided away from pedestrian routes

## Nosings

- Project no more than 25 mm
- Bevelled/curved leading edge between 6 mm and 10 mm
- Where projecting, be sloped to the riser at an angle not less than 60 degrees to the horizontal
- Flush between riser and tread
- Slip-resistant finish
- 70% colour/tonal contrast between nosing and tread
- Illuminated to minimum 100 lux

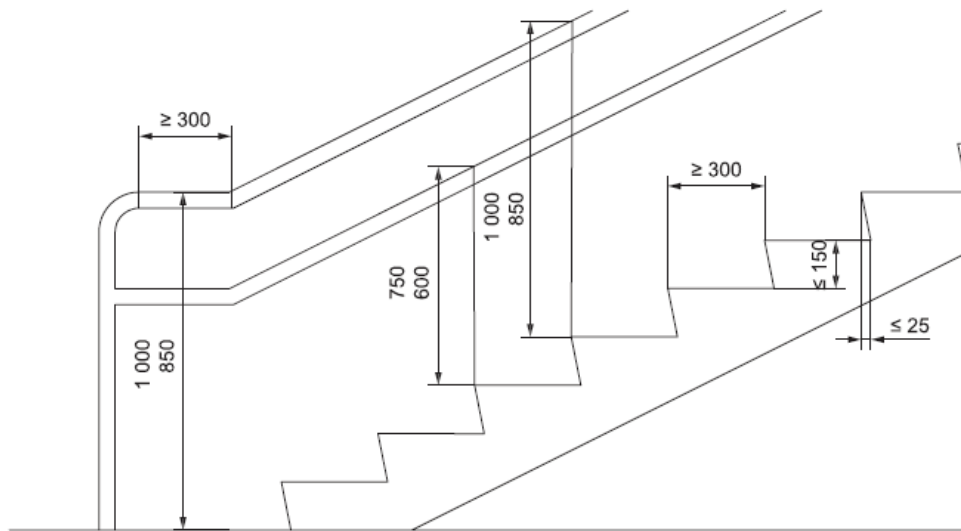

Figure 20: Recommended Dimensions for Rise of Steps and Heights of Handrails

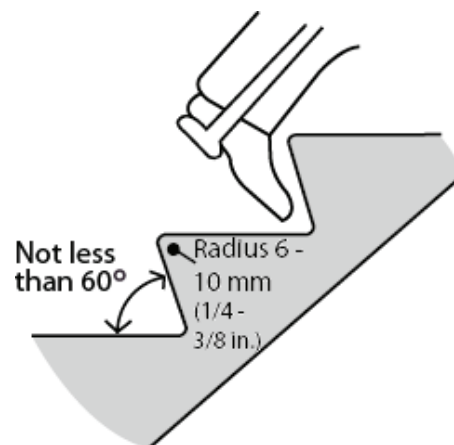

Figure 21: Raked Risers

## Stair Widths

- Minimum flight width: 1200 mm (1500 mm for evacuation stairs)
- Minimum clear width between handrails must be 1000 mm
- Retrofit allowance: 900 mm flight, 800 mm between handrails

## Staircase Landings

- Free of obstruction (including door swings)
- Distance between doors and descending stairs must be 2000 mm minimum
- Half landings/180° turns: Minimum 1500 mm width (see Figure 21)
- Intermediate landing length not less than the width of the widest channel

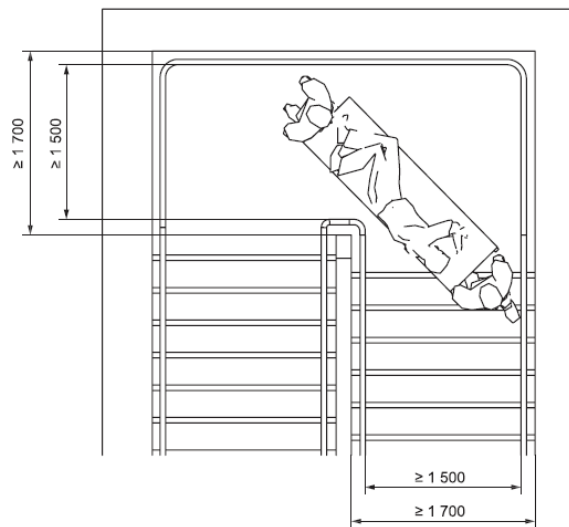

**Figure 22: Example of Stair and 180° Landing for Emergency Access**  
 \*Dimensions in millimetres

## Head Clearance

- Minimum 2100 mm clear height
- Where less, provide guard or detectable element to prevent impact (see Figure 21)

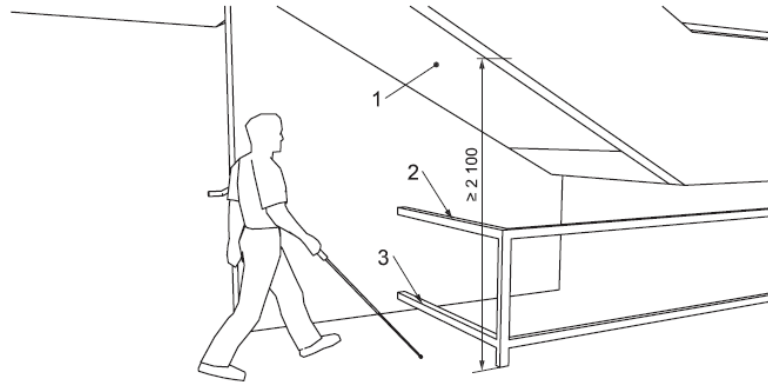

**Figure 23: Clear height under stairs**

\* Dimensions in millimetres

### Key

1. Minimum 2100 mm clear height
2. Guard against impact
3. Guard detectable with cane, maximum 300 mm above floor level

## Visual and Tactile Warnings

### Visual:

- Continuous 40-50 mm wide contrast strip with a minimum 70% colour/tonal contrast across the full width of each step (See Figure 22)
- May be set back a maximum of 15 mm from the front of the nosing
- As an alternative, a visual warning line with a width between 50 mm and 100 mm may be provided on the run of the first and last step of the flight

### Tactile warning:

- Provided on landings at the top and bottom of every flight of stairs, across the full width of the stair
- Depth between 600 mm and 900 mm and be set back between 300 mm to 500 mm from the edge of the top stair nosing and between 100 mm and 500 mm from the bottom riser

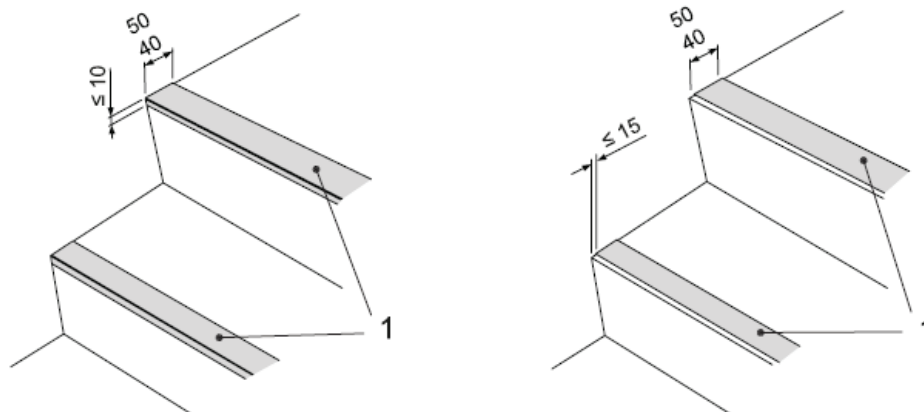

**Figure 24 - Visual Indicator on Stairs**

**Key**

- 1. Visual warning line

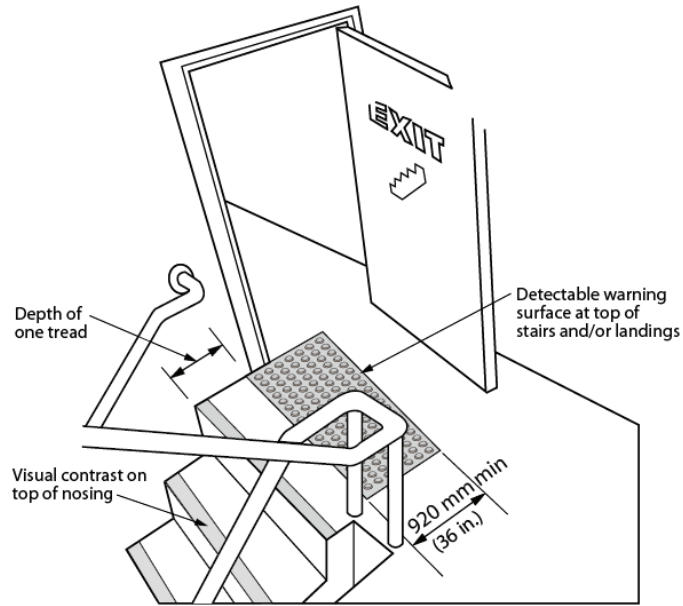

**Figure 25 - Tactile Attention Indicators at Stairs**

**Handrails and Guards**

- Handrails required on both sides (see Section 2.5 Handrails)
- Intermediate handrails required where stairs exceed 2200 mm wide
- Guards: minimum 900 mm at stairs; 1070 mm at landings
- Spiral/curved stairs: inside handrail parallel to going with minimum 220 mm length

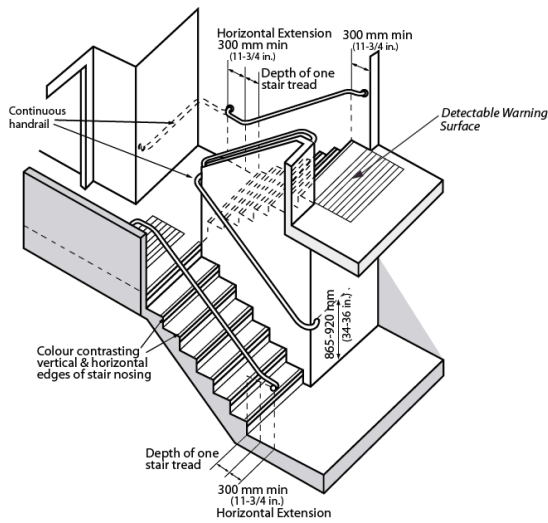

**Figure 26: Stair Design Criteria**

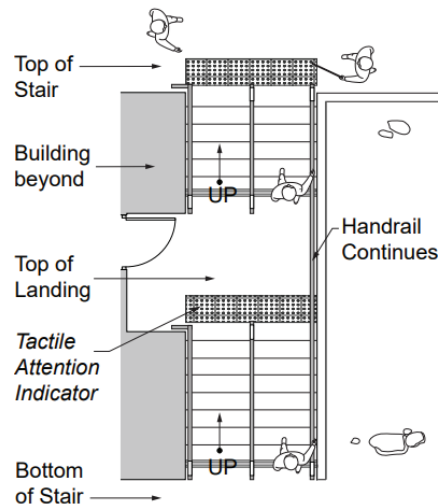

**Figure 27: Stair Landing Tactile Indicators**

Table 7: Stairs at a Glance

| Feature                  | Minimum / Recommended Dimensions  | Notes / Key Requirements  |
|--------------------------|---|---|
| <b>Flights of Stairs</b> | <ul style="list-style-type: none"> <li>Rise 125–175 mm (150 mm preferred outdoors)</li> <li>Run 280–355 mm</li> </ul>   | <ul style="list-style-type: none"> <li>No isolated steps</li> <li>No open risers</li> <li>Uniform dimensions</li> <li>Sum of run + 2×rise = 600–660 mm</li> </ul>   |
| <b>Width</b>             | <ul style="list-style-type: none"> <li>1200 mm min</li> <li>1500 mm for evacuation stairs</li> </ul>  | <ul style="list-style-type: none"> <li>Between handrails: 1000 mm min</li> <li>Exceptions in existing buildings: 900 mm flight / 800 mm between handrails</li> </ul>  |
| <b>Landings</b>          | <ul style="list-style-type: none"> <li>Top/bottom clear</li> <li>Intermediate landings ≥ width of widest stair channel</li> <li>Half-turn (180°) = 1500 mm min</li> </ul> | <ul style="list-style-type: none"> <li>Distance between doors and descending stairs = 2000 mm min</li> </ul>  |
| <b>Head Clearance</b>    | <ul style="list-style-type: none"> <li>≥2100 mm</li> </ul>  | <ul style="list-style-type: none"> <li>If &lt;2100 mm, provide cane-detectable guard ≤300 mm high</li> </ul>  |
| <b>Nosings</b>           | <ul style="list-style-type: none"> <li>Projection ≤25 mm</li> <li>Bevel 6–10 mm; slope ≥60°</li> </ul>  | <ul style="list-style-type: none"> <li>Flush to riser</li> <li>Slip-resistant</li> <li>Illuminated 100 lux</li> <li>High-contrast colour strip on tread</li> </ul>  |
| <b>Visual Warnings</b>   | <ul style="list-style-type: none"> <li>40–50 mm wide strip with Cm ≥60% (Cw ≥75%)</li> </ul>  | <ul style="list-style-type: none"> <li>Continuous across steps</li> <li>Can be on riser (≤10 mm high) or on run (50–100 mm wide); set back ≤15 mm from nosing</li> </ul>  |
| <b>Tactile Warnings</b>  | <ul style="list-style-type: none"> <li>Depth 600–900 mm</li> </ul>  | <ul style="list-style-type: none"> <li>At top: 300–500 mm back from nosing</li> <li>At bottom: 100–500 mm back from riser</li> <li>Full stair width</li> </ul>  |
| <b>Handrails</b>         | <ul style="list-style-type: none"> <li>865–920 mm height</li> </ul>   | <ul style="list-style-type: none"> <li>Both sides</li> <li>Continuous on switchbacks</li> <li>Extensions ≥300 mm top/bottom</li> <li>Return to wall/post</li> <li>Intermediate rails if &gt;2200 mm wide</li> </ul> |

| <b>Feature</b>               | <b>Minimum / Recommended Dimensions</b>   | <b>Notes / Key Requirements</b>   |
|------------------------------|---|---|
| <b>Guards</b>                | <ul style="list-style-type: none"> <li>• 900 mm min at stairs</li> <li>• 1070 mm min at landings</li> </ul> | <ul style="list-style-type: none"> <li>• Must meet OBC</li> <li>• Designed to prevent climbing</li> </ul>   |
| <b>Surface</b>               | <ul style="list-style-type: none"> <li>• Slip-resistant (wet/dry)</li> </ul>                                | <ul style="list-style-type: none"> <li>• Avoid abrupt material transitions</li> <li>• Provide designated snow storage away from pedestrian routes</li> </ul>                      |
| <b>Specialist Engagement</b> | <ul style="list-style-type: none"> <li>• N/A</li> </ul>   | <ul style="list-style-type: none"> <li>• Engage accessibility or safety consultant for retrofit projects, large-volume stairs, or where evacuation planning is complex</li> </ul> |

## 2.5 Handrails

### Rationale

Handrails provide essential support and stability for all users, particularly individuals with mobility impairments. Properly designed handrails reduce the risk of falls and make stairs and ramps safer. Handrails must be positioned at an accessible height, with a comfortable grip, and should be continuous to ensure support throughout the ascent or descent. For individuals with vision loss, clear color contrast and tactile markings are necessary for orientation. Adequate spacing between the handrail and wall ensures ease of use and prevents safety hazards.

### Application

This section applies to all handrails provided in both interior and exterior environments

### Requirements

#### Height of Handrails

- Mounted between 865 mm and 920 mm above the stair nosings and ramp surfaces
- If installed, secondary/lower handrail must be between 600 mm and 750 mm for ramps, stairs and landings

#### Gripping Surface

- Must have a circular cross-section between 30 mm to 40 mm in diameter, or a non-circular cross-section with a perimeter between 100 mm and 125 mm and a maximum cross-sectional dimension of 45 mm
- Must be a smooth, continuous surface free of sharp elements

#### Clearance

- Minimum clearance of 50 mm between handrail and adjacent surface
- Where the wall has a rough surface, the clearance must be at least 60 mm

#### Continuity and Extensions

- Continuous along ramps and stairs, including switchbacks
- At the top of a stair flight, handrails must extend horizontally at least 300 mm beyond the first riser
- Bottom extensions: continue to slope at least one tread depth beyond the last riser
- Return to wall, post or floor to avoid hazards

## Strength and Durability

- Must be securely fixed and capable of withstanding a minimum 1.7 kN load applied vertically and horizontally
- Must be designed and constructed to withstand the loading values obtained from the non-concurrent application of:
  - A concentrated load of at least 0.9 kN (200 lb.) applied at any point and in any direction
  - A uniform load of at least 0.7 kN/m (47 lb./ft.) applied in any direction to the handrail

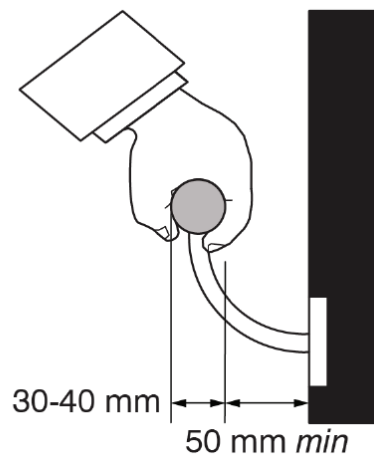

**Figure 28: Handrail and Distance to the Wall**

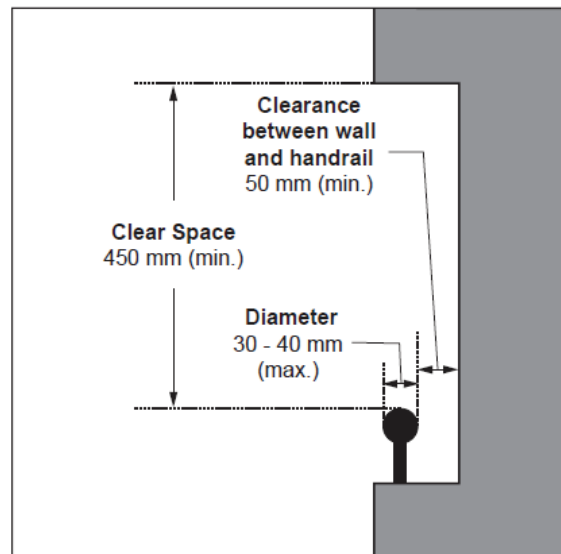
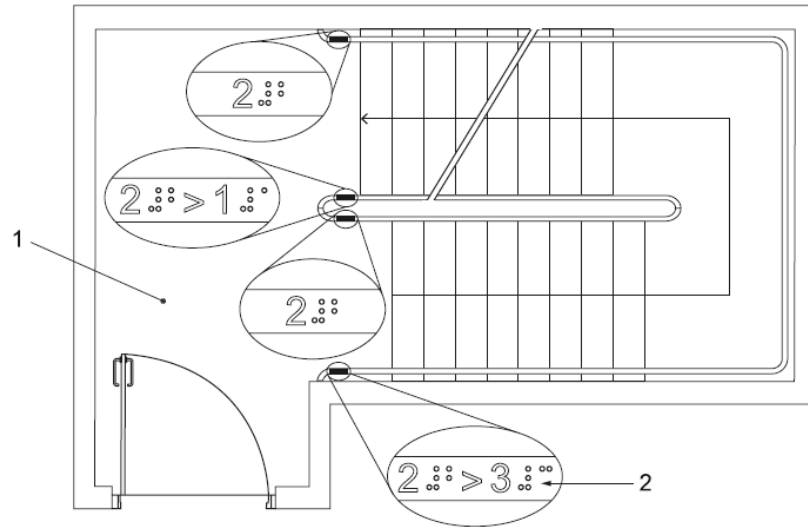

**Figure 29: Handrails in Recessed Area**

## Visual and Tactile Information

- Must have a minimum contrast of 70% with background
- Where possible, provide tactile and Braille information at the start/end of handrails on stairs and ramps: indicate floor number or exit direction per Section 5.9 Signage and Wayfinding
- Orientation must align with direction of travel

Figure 38 shows examples of visual and tactile information on handrails.



**Figure 30: Example of Tactile Information**

### Key

1. Platform of the second floor
2. Information on current floor and the floor to be reached by the stairs as tactile characters and in Braille

NOTE: Information is readable by touch and its orientation corresponds to the direction of travel.

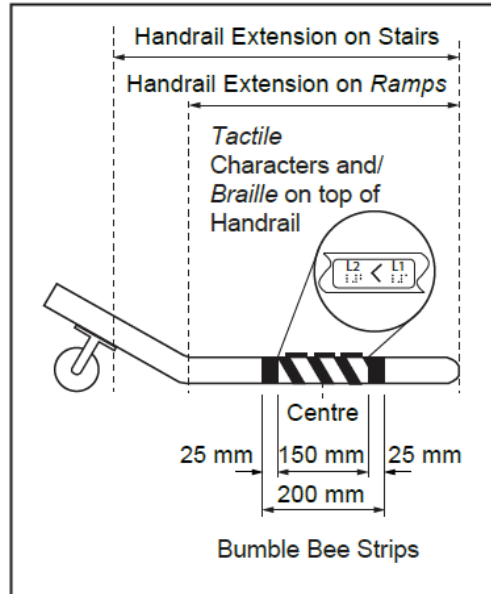

Figure 31: Bumble Bee Strips, Tactile Characters and Braille

Table 8: Handrails at a Glance

| Feature                          | Minimum / Recommended Dimensions  | Notes / Key Requirements   |
|----------------------------------|---|--|
| <b>Height</b>                    | <ul style="list-style-type: none"> <li>Upper rail: 865–920 mm above stair nosing/ramp surface</li> <li>Lower rail: 600–750 mm</li> </ul>                      | <ul style="list-style-type: none"> <li>If other heights provided, must be in addition to required handrail</li> </ul>  |
| <b>Gripping Surface</b>          | <ul style="list-style-type: none"> <li>Circular: 30–40 mm Ø</li> <li>Non-circular: perimeter 100–125 mm, max 45 mm cross-section</li> </ul>                   | <ul style="list-style-type: none"> <li>Continuous, smooth, comfortable to grasp; no sharp/abrasive elements</li> </ul> |
| <b>Clearance from Wall</b>       | <ul style="list-style-type: none"> <li>≥50 mm (≥60 mm if wall surface is rough)</li> </ul>  | <ul style="list-style-type: none"> <li>Prevents obstruction or pinching hazard</li> </ul>                              |
| <b>Continuity</b>                | <ul style="list-style-type: none"> <li>Continuous along full length of stairs and ramps</li> </ul>  | <ul style="list-style-type: none"> <li>Must not be interrupted by posts or fittings</li> </ul>                         |
| <b>Extensions</b>                | <ul style="list-style-type: none"> <li>Top: ≥300 mm horizontal beyond first riser</li> <li>Bottom: slope of stair ≥1 tread depth beyond last riser</li> </ul> | <ul style="list-style-type: none"> <li>Provide support during approach/departure</li> </ul>                            |
| <b>Termination</b>               | <ul style="list-style-type: none"> <li>Return to wall, guard, or floor</li> </ul>   | <ul style="list-style-type: none"> <li>Must not obstruct travel or create hazards</li> </ul>                           |
| <b>Strength &amp; Durability</b> | <ul style="list-style-type: none"> <li>Withstand 1.7 kN (vertical/horizontal point load)</li> <li>0.9 kN concentrated load</li> </ul>                         | <ul style="list-style-type: none"> <li>Securely fixed, resistant to heavy use</li> </ul>                               |

| Feature                      | Minimum / Recommended Dimensions   | Notes / Key Requirements   |
|------------------------------|--|--|
|                              | <ul style="list-style-type: none"> <li>• 0.7 kN/m uniform load</li> </ul>  |  |
| <b>Visual Contrast</b>       | <ul style="list-style-type: none"> <li>• <math>\geq 70\%</math> luminance contrast with adjacent background</li> </ul> | <ul style="list-style-type: none"> <li>• Aids users with low vision</li> </ul>   |
| <b>Tactile/Info Features</b> | <ul style="list-style-type: none"> <li>• Tactile/Braille info at start and end of handrails</li> </ul>                 | <ul style="list-style-type: none"> <li>• Indicate floor number or exit direction</li> <li>• Follow Section 5.8 Signage &amp; Wayfinding</li> </ul> |
| <b>Specialist Engagement</b> | <ul style="list-style-type: none"> <li>• N/A</li> </ul>  | <ul style="list-style-type: none"> <li>• For tactile signage integration, consult accessibility or wayfinding specialists</li> </ul>               |

## 2.6 Overhanging and Protruding Objects

### Rationale

Overhead objects and protrusions, whether temporary or permanent, must be cane detectable to ensure individuals using mobility aids, including white canes, can identify them. Objects should be placed such that they do not reduce the required clear width of any accessible path.

### Application

This section applies to all accessible paths in both interior and exterior environments where overhead objects or protrusions may be present. All protruding objects must be designed to comply with the requirements outlined for headroom clearance, space requirements, and cane detectability.

### Design Requirements

#### Headroom Clearance

Where present, overhead objects must provide the following clearances:

- A minimum clear height of 2100 mm
- Where headroom clearance is less than 2100 mm from floor level (e.g., underside of stairs, escalators or landings), cane detectable guards must be installed with the leading edge at a maximum height of 680 mm above the floor

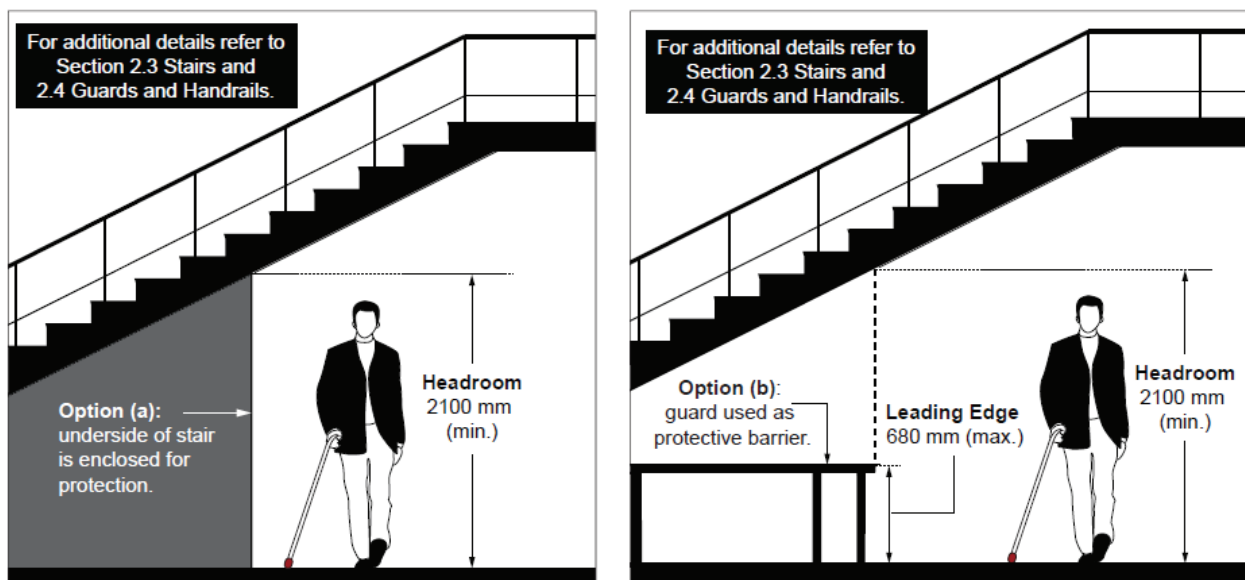

Figure 32: Protection Options Underneath Stairs

## Protruding Objects

When objects protrude into accessible paths, the following must be ensured:

- The required clear width of accessible paths or maneuvering spaces must not be reduced
- Objects that protrude should not extend more than 100 mm into the path, unless they are cane detectable at or below 680 mm above the floor

**Note:** Protruding objects must have a contrast ratio of at least 30% to their background to improve visibility, with a minimum height of 100 mm for detectable plinths.

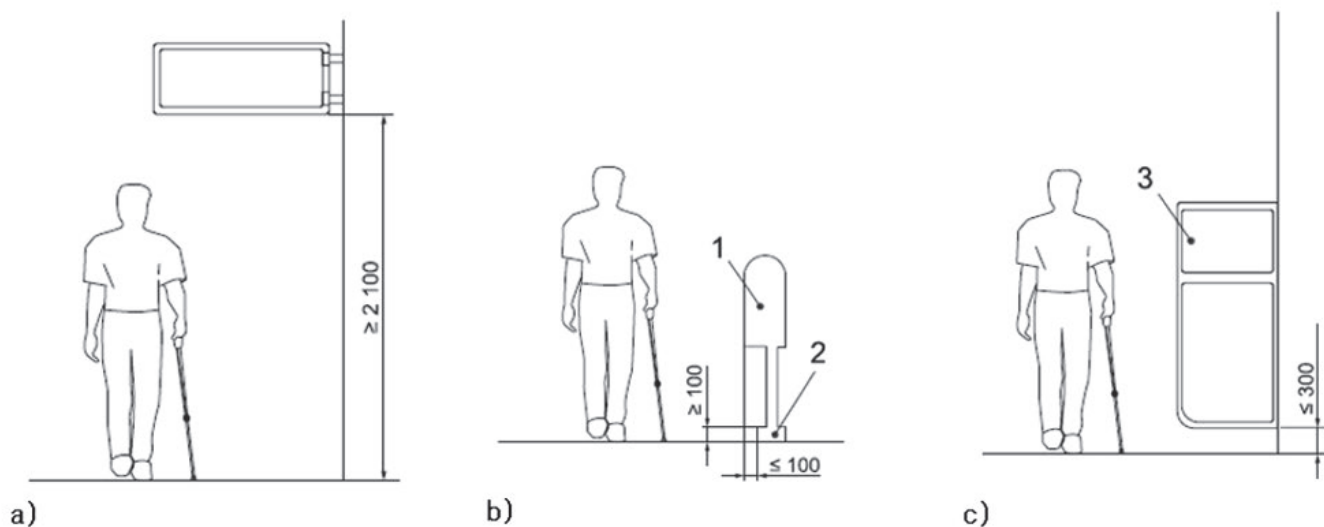

Figure 33 a, b & c: Protruding Objects

### Key

1. Projecting objects must have a luminance contrast to background of  $C_m \geq 30\%$  ( $C_w \geq 45\%$ )
2. Base plinths detectable by cane should project objects with a minimum height of 100 mm
3. Winged protection

Table 9 – Protruding Objects at a Glance

| Feature                     | Minimum / Recommended Dimensions   | Notes / Key Requirements  |
|-----------------------------|--|---|
| <b>Headroom Clearance</b>   | <ul style="list-style-type: none"> <li>• <math>\geq 2100</math> mm clear height</li> <li>• If <math>&lt; 2100</math> mm, cane-detectable guard with leading edge <math>\leq 680</math> mm AFF</li> </ul> | <ul style="list-style-type: none"> <li>• Guards required under stairs, escalators, landings</li> <li>• Guards must extend to within 300 mm of floor for cane detection</li> </ul> |
| <b>Protrusion into Path</b> | <ul style="list-style-type: none"> <li>• Objects must not project <math>&gt; 100</math> mm unless cane-detectable at <math>\leq 680</math> mm AFF</li> </ul>   | <ul style="list-style-type: none"> <li>• Clear width of accessible path must be maintained</li> </ul>   |
| <b>Detectable Plinths</b>   | <ul style="list-style-type: none"> <li>• <math>\geq 100</math> mm high base plinth</li> </ul>  | <ul style="list-style-type: none"> <li>• Makes objects cane-</li> </ul>   |

| Feature                              | Minimum / Recommended Dimensions   | Notes / Key Requirements  |
|--------------------------------------|--|---|
|                                      |  | detectable where otherwise not<br><ul style="list-style-type: none"> <li>• Must be firmly fixed, not decorative only</li> </ul>                                 |
| <b>Visual Contrast</b>               | <ul style="list-style-type: none"> <li>• <math>\geq 30\%</math> luminance contrast with adjacent background</li> </ul> | <ul style="list-style-type: none"> <li>• Improves visibility for low-vision users</li> </ul>  |
| <b>Temporary/Tactical Protection</b> | <ul style="list-style-type: none"> <li>• N/A</li> </ul>  | <ul style="list-style-type: none"> <li>• Recess, relocate, or shield projecting objects</li> <li>• Winged guards permitted to improve cane-detection</li> </ul> |

## 2.7 Rest Areas

### Rationale

Rest areas are essential components of inclusive outdoor environments, offering predictable opportunities to pause, recover, and participate in community life. They reduce barriers for people with disabilities, older adults, children, and others who may not be able to travel long distances without breaks.

### Application

Applies to all newly constructed or redeveloped exterior paths of travel maintained by the City.

### Design Requirements

When constructing new or redeveloping exterior paths of travel, consultation on the design and placement of rest areas along the exterior path of travel must include:

- The Mississauga Accessibility Advisory Committee
- The public
- People with disabilities

Rest areas must:

- Be provided at predictable intervals along exterior routes (where possible)
  - 30-50m in high-use or urban areas (preferred)
  - Up to 90m along recreational trails, with flexibility for topography and context
- Locate rest areas adjacent to, but clear of, the accessible path of travel
- Provide a dedicated level and clear space of 1800 mm by 1800 mm minimum
  - If a bench or seat is provided (recommended where possible), allow clear ground space of 900 mm by 1500 mm for a front approach
  - Benches and seats must comply with Section 2.11 Seating, Tables and Work Surfaces
- Where provided, weather protection shelters must:
  - Have a minimum overhead clearance of 3000 mm
  - Be located above benches and seating
- Provide high contrast finishes and clear sightlines for visibility and safety

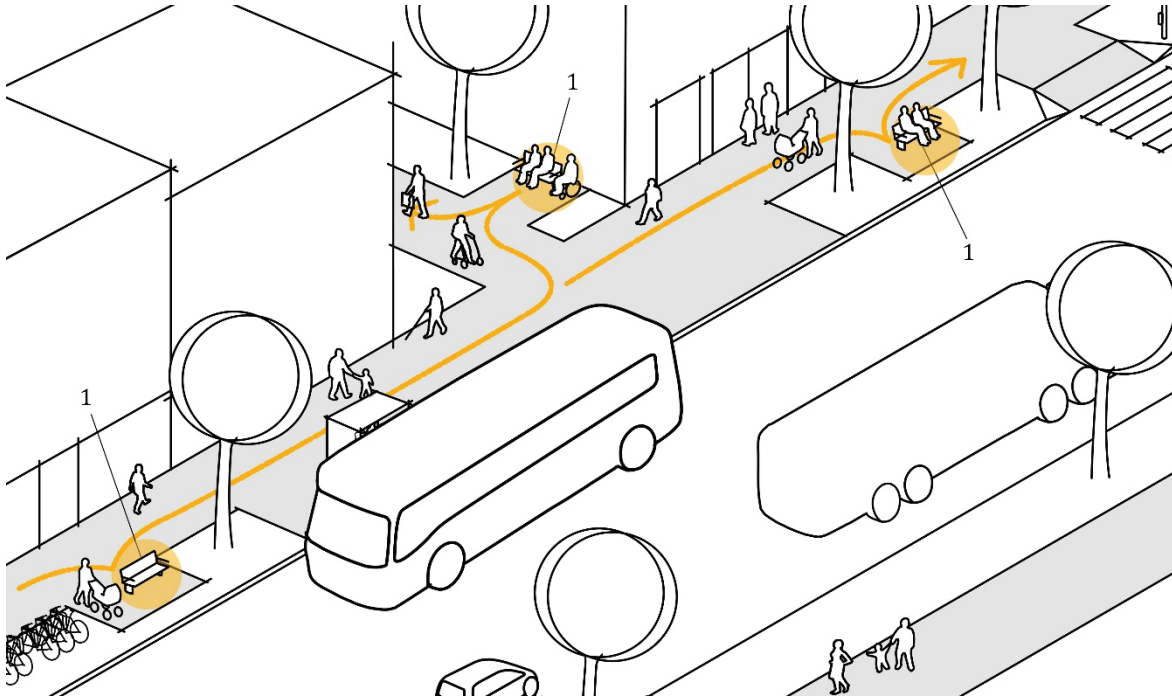

**Figure 33: Rest Areas on Accessible Routes**

**Key**

1. Seating at regular intervals in level recessed spaces, accommodating users of wheeled mobility devices

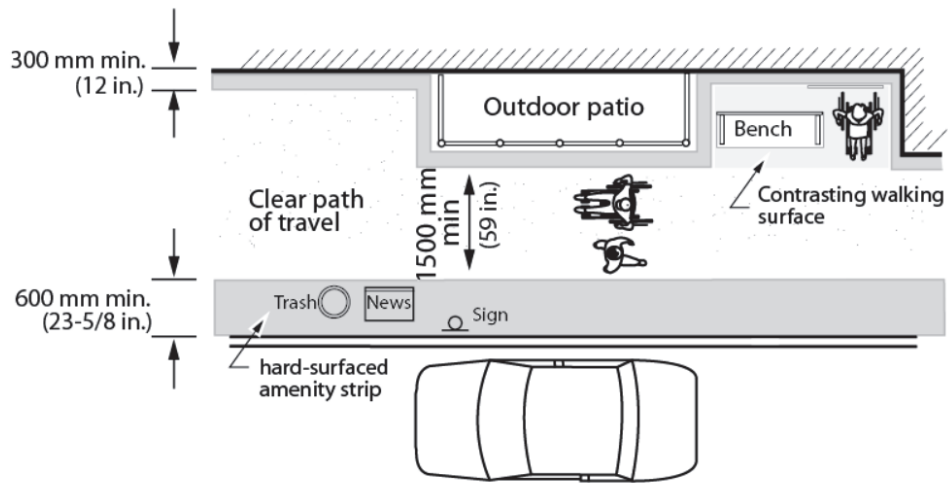

**Figure 34 - Streetscape**

Table 10: Rest Areas at a Glance

| Feature                        | Minimum / Recommended Dimensions  | Notes / Key Requirements  |
|--------------------------------|---|---|
| <b>Consultation</b>            | <ul style="list-style-type: none"> <li>N/A</li> </ul>   | <ul style="list-style-type: none"> <li>Must include Mississauga Accessibility Advisory Committee, public, and people with disabilities</li> </ul>     |
| <b>Interval / Location</b>     | <ul style="list-style-type: none"> <li>30–50 m in high-use or urban areas (preferred)</li> <li>Up to 90 m on recreational trails</li> </ul> | <ul style="list-style-type: none"> <li>Rest areas must be predictable, context-sensitive, and adjacent to but clear of the accessible path</li> </ul> |
| <b>Clear Space</b>             | <ul style="list-style-type: none"> <li>1800 mm × 1800 mm minimum</li> </ul>   | <ul style="list-style-type: none"> <li>Dedicated level space for resting and maneuvering</li> </ul>   |
| <b>Bench / Seating Space</b>   | <ul style="list-style-type: none"> <li>900 mm × 1500 mm clear space (front approach)</li> </ul>   | <ul style="list-style-type: none"> <li>Benches/seats recommended</li> <li>Must comply with Section 2.11 Seating, Tables and Work Surfaces</li> </ul>  |
| <b>Weather Protection</b>      | <ul style="list-style-type: none"> <li>Overhead clearance 3000 mm minimum</li> <li>Shelter located above benches/seating</li> </ul>         | <ul style="list-style-type: none"> <li>Optional feature</li> <li>Enhances comfort and usability</li> </ul>  |
| <b>Visibility &amp; Safety</b> | <ul style="list-style-type: none"> <li>N/A</li> </ul>   | <ul style="list-style-type: none"> <li>High contrast finishes and clear sightlines required for safety and legibility</li> </ul>                      |

## 2.8 Tactile Walking Surface Indicators

### Rationale

Tactile Attention Indicators (TAIs) provide critical navigational cues for individuals with visual impairments. These surfaces alert pedestrians to potential hazards, such as crosswalks or stairs. Suitable tactile surfaces should change in texture and offer high color contrast without posing tripping hazards.

### Application

TAIs should be installed at key locations, including walkways, curb ramps, stairs, and elevated platforms, in compliance with this section.

Other Potential Hazards:

- **Crosswalk Transitions:** Install TAIs where pedestrian walkways intersect with vehicular roads to signal traffic hazards
- **Platform Edges:** At transit platforms or loading docks, TAIs should be placed along the edges to warn users of drop-offs
- **Depressed Curbs:** At pedestrian crossings, install detectable surfaces to mark the transition zone
- **Cycle Tracks and Multi-Use Paths:** Use TAIs where pedestrian paths cross cycle or multi-use trails
- **Escalators and Moving Walkways:** Provide warning surfaces at entry/exit points to signal transitions
- **Emergency Exits and Ramps:** Place TAIs near emergency exit doors, especially where they lead to stairs, ramps, or sudden elevation changes
- **Hazardous Zones:** Install TAIs near fountains, atriums, or areas with uneven flooring where hazards might not be immediately visible

### Design Requirements

#### General Detectability

- All tactile surfaces must be detectable when walked upon and distinct from surrounding surfaces. Paint finishes on concrete surfaces do not provide adequate detectability

#### Visual Contrast

- TAIs must contrast with adjoining surfaces using light-on-dark or dark-on-light schemes.

## Slip Resistance

- TAIs should be slip-resistant in both dry and wet conditions.

## Stair Applications

- TAI placement should:
- Extend across the top of stairs and landings, at least 920 mm wide
- Be installed no more than 3 mm above or below adjacent surfaces for interior stairs
- Flat-topped domes or cones are preferred

## Curb Ramps, Depressed Curbs, Exit Stairs, and Elevated Platforms

- TAIs should have flat-topped domes or cones, with a height of 4–5 mm and dimensions as specified in Table 6.

## Walkway Crossings

- Install a continuous detectable warning surface at the boundary between pedestrian and vehicular areas, with a minimum width of 920 mm to clearly mark the boundary

**Table 11: Size and Spacing of Flat-Topped Domes or Cones**

| Top diameter of flat-topped domes or cones (mm) | Spacing between the centres of adjacent domes (mm) |
|---|--|
| 12  | 42 – 61  |
| 15  | 45 – 63  |
| 18  | 48 – 65  |
| 20  | 50 – 68  |
| 25  | 55 - 70  |

Bottom diameter of flat-topped domes or cones  $10 \pm 1$  greater than the top diameter.

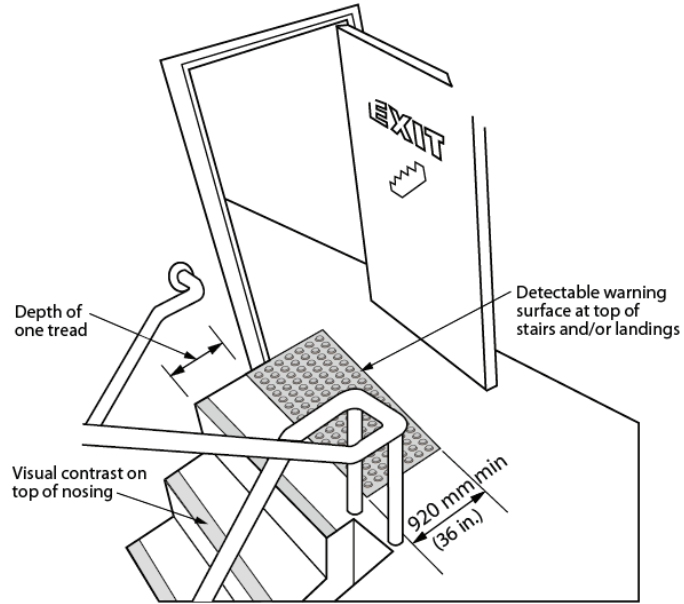

**Figure 35: Tactile Attention Indicators at Stairs**

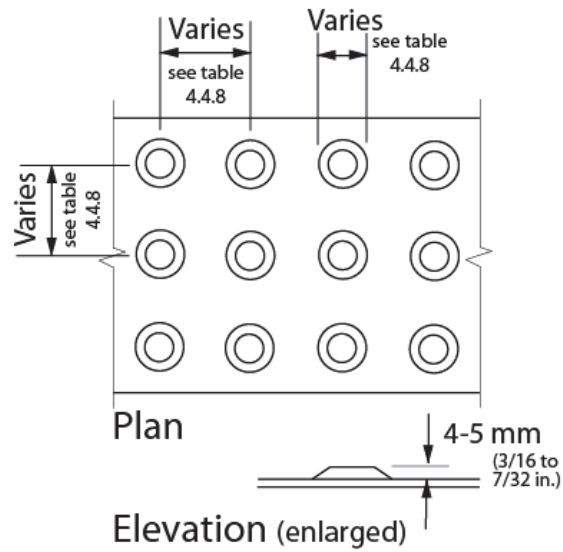

**Figure 36: Truncated Dome Detectable Warning Surface**

Table 12: Tactile Walking Surface Indicators at a Glance

| Feature                                       | Minimum / Recommended Dimensions  | Notes / Key Requirements   |
|---|---|--|
| <b>General Detectability</b>                  | <ul style="list-style-type: none"> <li>N/A</li> </ul>   | <ul style="list-style-type: none"> <li>Must be tactile underfoot and distinct from surroundings</li> <li>Paint-only finishes are not acceptable</li> </ul> |
| <b>Visual Contrast</b>                        | <ul style="list-style-type: none"> <li>≥70% tonal contrast with adjacent surface</li> </ul>   | <ul style="list-style-type: none"> <li>Use light-on-dark or dark-on-light schemes</li> </ul>   |
| <b>Slip Resistance</b>                        | <ul style="list-style-type: none"> <li>N/A</li> </ul>   | <ul style="list-style-type: none"> <li>Surfaces must be slip-resistant in wet and dry conditions</li> </ul>  |
| <b>Stair Applications</b>                     | <ul style="list-style-type: none"> <li>Depth: ≥920 mm at landings and stair tops</li> <li>Height variation: ±3 mm max</li> </ul>                | <ul style="list-style-type: none"> <li>Flat-topped domes or cones preferred</li> </ul>   |
| <b>Curb Ramps, Depressed Curbs, Platforms</b> | <ul style="list-style-type: none"> <li>Dome/cone height: 4–5 mm</li> <li>Diameter: 12–25 mm (per Table 6)</li> <li>Spacing: 42–70 mm</li> </ul> | <ul style="list-style-type: none"> <li>Bottom diameter = Top diameter +10 ± 1 mm</li> </ul>  |
| <b>Walkway Crossings</b>                      | <ul style="list-style-type: none"> <li>Continuous strip ≥920 mm wide</li> </ul>   | <ul style="list-style-type: none"> <li>Defines boundary between pedestrian and vehicular areas</li> </ul>  |
| <b>Hazard Zones</b>                           | <ul style="list-style-type: none"> <li>N/A</li> </ul>   | <ul style="list-style-type: none"> <li>Provide TAIs near fountains, atriums, escalators, exits, and other hazards</li> </ul>                               |
| <b>Special Contexts</b>                       | <ul style="list-style-type: none"> <li>N/A</li> </ul>   | <ul style="list-style-type: none"> <li>Required at cycle track crossings, multi-use paths, and emergency exits leading to stairs/ramps</li> </ul>          |

## 2.9 Tactile Direction Indicators

### Rationale

Tactile Direction Indicators (TDIs) are vital components of Tactile Walking Surface Indicators (TWSIs), providing continuous guidance for individuals with visual impairments. These indicators help users navigate along designated paths and reach their destinations independently. Proper use of TDIs ensures seamless wayfinding in both indoor and outdoor spaces.

### Application

- **Guidance Functionality:** TDIs should guide users along pedestrian pathways, from access points to destination points, in places like transit stations, public facilities and outdoor walkways
- **Location:** TDIs must be installed along accessible paths of travel, at passenger pick-up/drop-off areas, and at major building entrances
- **Indoor and Outdoor Use:** TDIs should be integrated with surrounding built and natural guiding elements, suitable for both indoor and outdoor environments
- **Complementary Role:** TDIs should complement warning indicators, decision points, and physical safety measures such as guardrails to enhance navigability
- **Limitations:** TDIs must not be installed where natural guiding elements (walls, curbs, railings or continuous landscaping) already provide clear orientation, to avoid redundancy or confusion

### Design Requirements

#### Dimensions and Standards

- **Width:** TDIs must be at least 250 mm wide for effective guidance
- **Height:** Tactile ridges or grooves should be 4–5 mm high for detectability

#### Layout and Continuity

- TDIs must form a continuous path from entry to destination, easy to follow with minimal need for user training

#### Positioning and Safety

- TDIs must maintain at least 300 mm of clearance from obstacles to ensure unimpeded use
- TDIs must not create parallel or ambiguous paths that may cause confusion

### Contrast and Visibility

- TDIs should contrast visually with surrounding surfaces using light-on-dark or dark-on-light schemes, ensuring high visibility under various lighting conditions

### Decision Points Integration

- At intersections or direction changes, TDIs should connect with decision points marked by tactile surfaces of at least 600 mm by 600 mm

### Durability and Slip Resistance

- TDIs should be made from durable, slip-resistant materials suitable for their environment, ensuring safety in both wet and dry conditions

**Table 7: Top Width and Centre-to-Centre Spacing Requirements**

| Top Width of Flat-Topped Elongated Bars (mm) | Spacing Centre-to-Centre (mm) |
|--|-------------------------------|
| 17   | 57 to 78                      |
| 20   | 60 to 80                      |
| 25   | 65 to 83                      |
| 30   | 70 to 85                      |

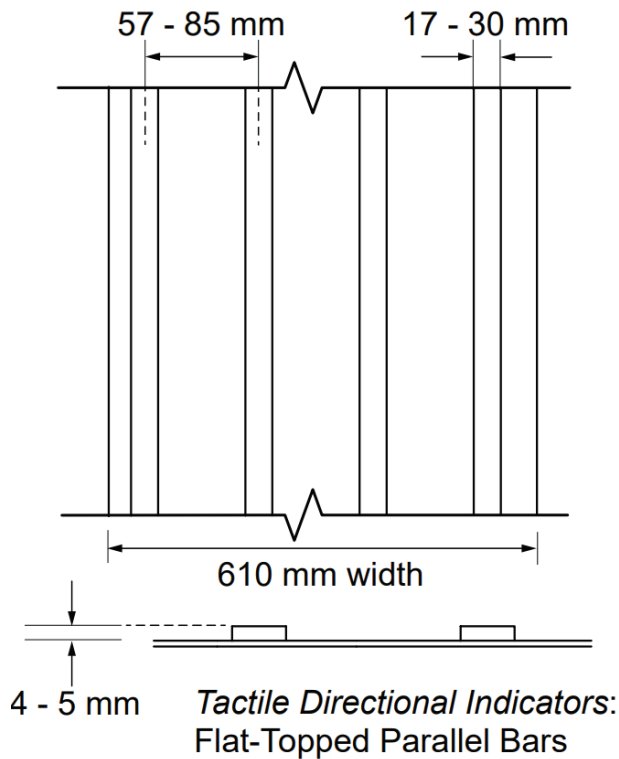

**Figure 37: Tactile Direction Indicator**

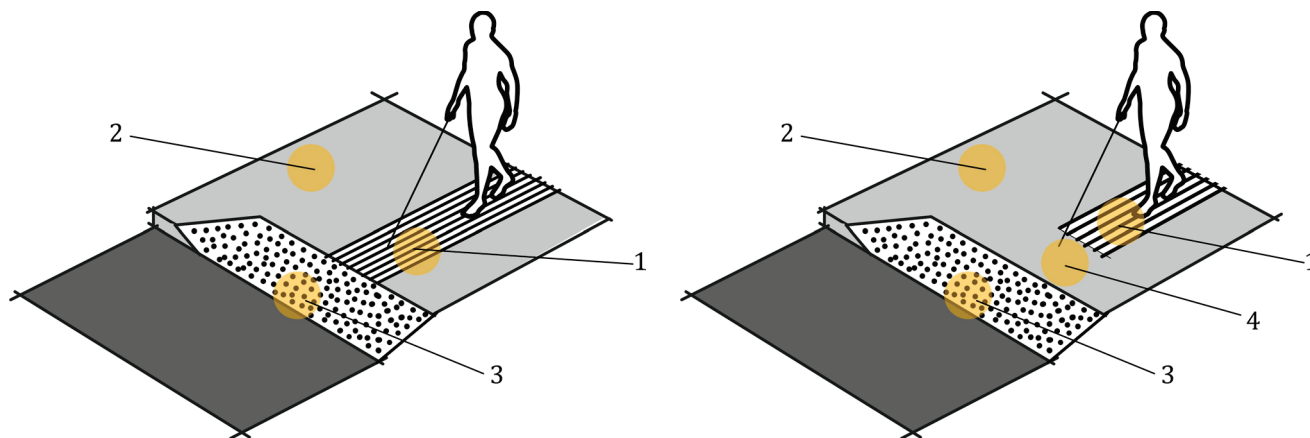

**Figure 38: Tactile Direction Indicator**

**Key**

1. TWSI with guiding pattern featuring difference in tactile feedback and visual contrast to adjacent surface
2. Adjacent surface with adequate visual and tactile contrast
3. TWSI with attention pattern featuring differences in tactile feedback to guiding pattern and adjacent surface
4. Gap between guiding pattern and attention pattern

**Table 13: Tactile Direction Indicators at a Glance**

| Feature                          | Minimum / Recommended Dimensions  | Notes / Key Requirements  |
|----------------------------------|---|---|
| <b>Width</b>                     | <ul style="list-style-type: none"> <li>• <math>\geq 250</math> mm</li> </ul>                                  | <ul style="list-style-type: none"> <li>• Ensures detectable and usable guidance path</li> </ul>   |
| <b>Height</b>                    | <ul style="list-style-type: none"> <li>• 4–5 mm</li> </ul>  | <ul style="list-style-type: none"> <li>• Detectable by cane or underfoot</li> </ul>   |
| <b>Spacing (Bars)</b>            | <ul style="list-style-type: none"> <li>• 17 mm top width <math>\rightarrow</math> 57–78 mm spacing</li> </ul> | <ul style="list-style-type: none"> <li>• See Table 7 for full spacing matrix (up to 30 mm top width <math>\rightarrow</math> 70–85 mm spacing)</li> </ul>     |
| <b>Continuity</b>                | <ul style="list-style-type: none"> <li>• Continuous from entry to destination</li> </ul>                      | <ul style="list-style-type: none"> <li>• Connect with decision points <math>\geq 600 \times 600</math> mm</li> </ul>  |
| <b>Clearance from Obstacles</b>  | <ul style="list-style-type: none"> <li>• <math>\geq 300</math> mm</li> </ul>                                  | <ul style="list-style-type: none"> <li>• Prevents obstruction</li> <li>• Ensures usability</li> </ul>   |
| <b>Installation Contexts</b>     | <ul style="list-style-type: none"> <li>• N/A</li> </ul>   | <ul style="list-style-type: none"> <li>• Must not be installed where natural guiding elements (walls, curbs, guardrails) provide clear orientation</li> </ul> |
| <b>Path Integrity</b>            | <ul style="list-style-type: none"> <li>• N/A</li> </ul>   | <ul style="list-style-type: none"> <li>• Must not create parallel or ambiguous paths</li> </ul>   |
| <b>Contrast &amp; Visibility</b> | <ul style="list-style-type: none"> <li>• Light-on-dark or dark-on-light</li> </ul>                            | <ul style="list-style-type: none"> <li>• <math>\geq 70\%</math> contrast with adjacent surfaces</li> </ul>  |

| Feature                                 | Minimum / Recommended Dimensions   | Notes / Key Requirements   |
|---|--|--|
| <b>Durability &amp; Slip Resistance</b> | <ul style="list-style-type: none"> <li>• N/A</li> </ul>  | <ul style="list-style-type: none"> <li>• Materials must be durable, slip-resistant in wet/dry conditions</li> </ul>                              |
| <b>Applications</b>                     | <ul style="list-style-type: none"> <li>• Entrances, pick-up/drop-off, major circulation paths</li> </ul> | <ul style="list-style-type: none"> <li>• Indoor and outdoor</li> <li>• Complement decision points, warning indicators, and guardrails</li> </ul> |

## 2.10 Drinking Fountains and Bottle Filling Stations

### Rationale

Accessible drinking fountains and bottle stations provide critical hydration for all users, including individuals with disabilities. Properly designed fountains help ensure that users with mobility aids, children, or those with limited dexterity can access water safely and independently. The design should focus on easy access, clear space, and ergonomic functionality for a wide range of users.

### Application

This section applies to drinking fountains where provided throughout the interior and exterior environments.

### Requirements

#### Design and Layout

Where drinking fountains are provided:

- At least one drinking fountain and one bottle filling station must be accessible to all users, including lowered units for individuals using mobility aids, people of short stature, children and others who may have difficulty bending or limited manual dexterity
- Where only one drinking fountain is installed, it must be an accessible, lowered unit
- Drinking fountains and bottle filling stations must be located along an accessible route, recessed, or equipped with a cane-detectable feature. The bottom edge should be no higher than 680 mm maximum from the floor
- Drinking fountain and bottle filling station fixtures must be color contrasted with the surroundings for easy identification

#### Floor Space Requirements and Approach

- Provide clear floor space of 915 mm wide by 1370 mm deep (minimum) in front of the drinking fountain and bottle filling station for a forward approach (see Figure 19)
- For a side approach, provide clear floor space of 1525 mm wide by 915 mm deep (minimum) in front of the fountain/station (see Figure 19)
- Ensure that one side is unobstructed and adjoins accessible route or another clear floor area
- Ensure that the clear floor space does not overlap the accessible route leading to the drinking fountain and bottle filling station

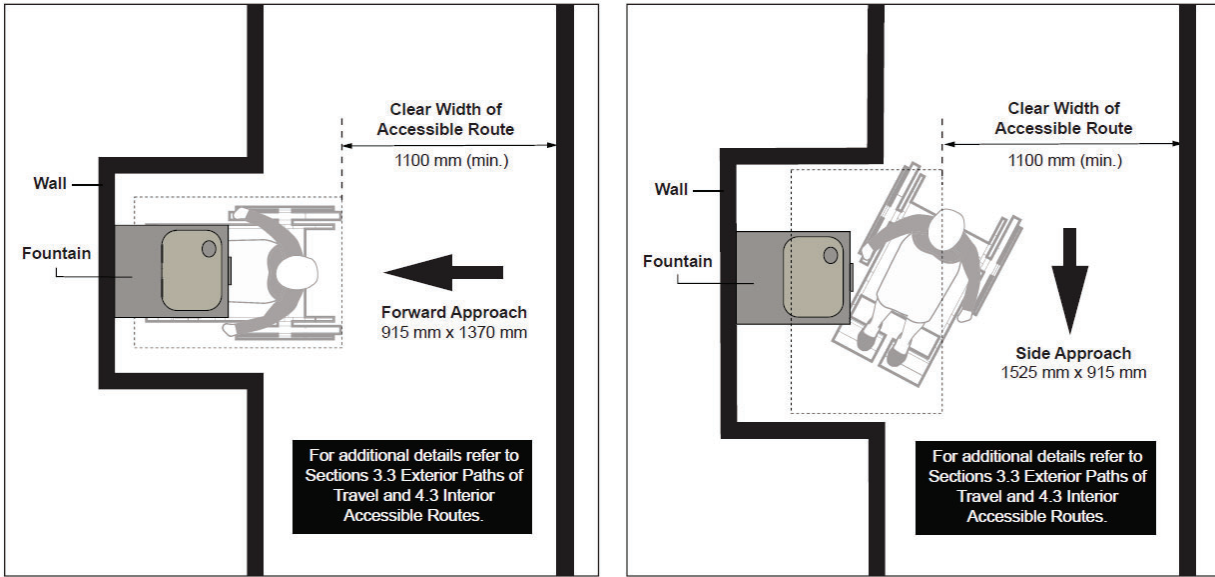

**Figure 39: Clear Floor Space Requirements and Approach at Recessed Drinking Fountain – Plan View**

## Knee and Toe Clearances

Where drinking fountains and bottle filling stations are provided:

- Knee clearance must be at least 760 mm wide by 450 mm deep at a height of 735 mm above the floor (see Figure 20)
- Toe clearance must be at least 350 mm high above the floor, measured from 300 mm back from the front edge to the wall
- Ensure a minimum depth of 700 mm at the foot of the fountain

## Operating Controls

Drinking fountains must have controls that:

- Are not foot-operated
- Are located at or near the front of the drinking fountain (see Figure 38)
- Can be operated with one hand, requiring a maximum force of 22 Newtons. The controls should not require twisting, pinching or wrist movement and must allow for automatic or hands-free operation

## Waterspout

The waterspout must be:

- Mounted no higher than 915 mm above the finished floor (see Figure 38)
- Positioned no more than 125 mm from the front edge of the fountain
- Set to ensure that water flows at least 100 mm high
- Positioned to allow water to flow at a vertical angle of:

- 30 degrees maximum for spouts located less than 75 mm from the front of the unit, or
- 15 degrees maximum for spouts located between 75 mm and 125 mm from the front of the unit

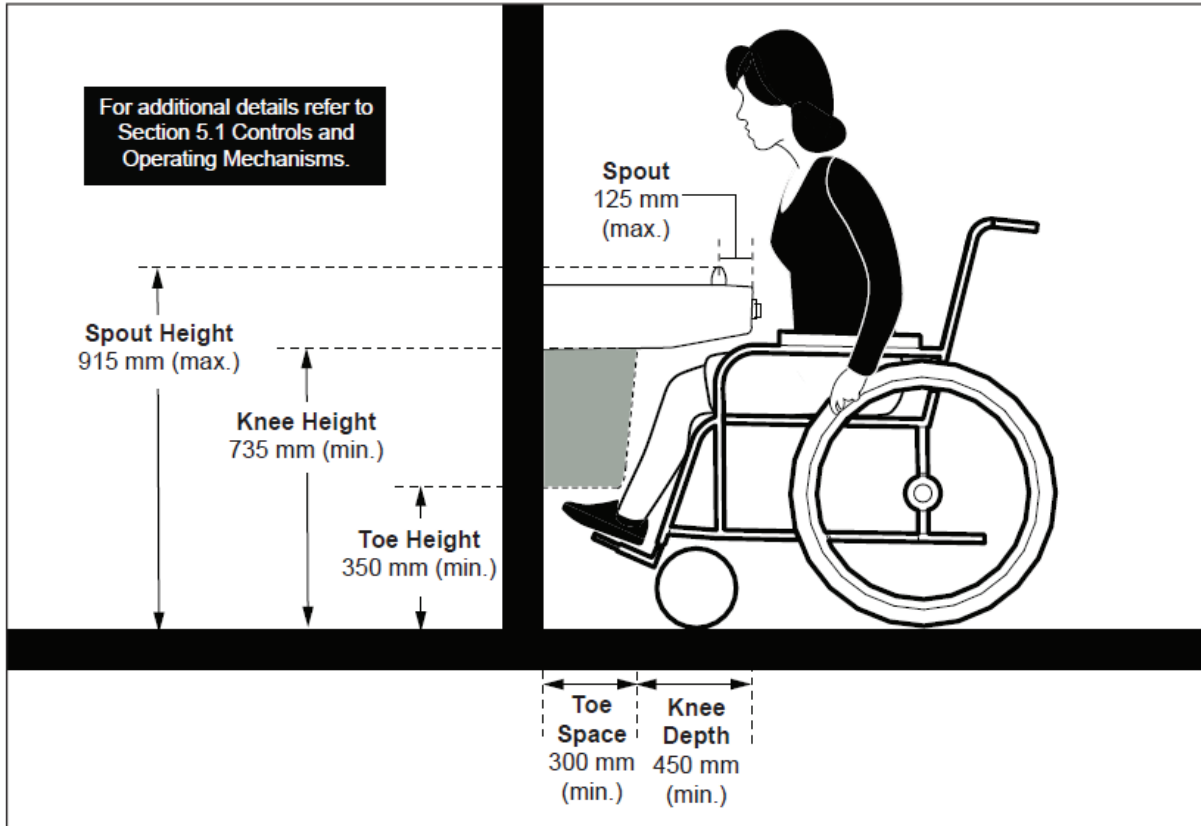

Figure 40: Drinking Fountain Design and Layout – Elevation View

Table 14 – Drinking Fountains &amp; Bottle Filling Stations at a Glance

| Feature                              | Minimum / Recommended Dimensions   | Notes / Key Requirements  |
|--------------------------------------|--|---|
| <b>Units Required</b>                | <ul style="list-style-type: none"> <li>At least 1 fountain + 1 bottle filler accessible</li> </ul> | <ul style="list-style-type: none"> <li>If only 1 unit is provided, it must be a lowered accessible unit</li> </ul>                        |
| <b>Mounting Height (Bottom Edge)</b> | <ul style="list-style-type: none"> <li>≤680 mm from floor</li> </ul>                               | <ul style="list-style-type: none"> <li>Must be cane-detectable or recessed</li> </ul>   |
| <b>Clear Floor Space – Forward</b>   | <ul style="list-style-type: none"> <li>915 mm wide × 1370 mm deep</li> </ul>                       | <ul style="list-style-type: none"> <li>Must not overlap accessible route</li> </ul>   |
| <b>Clear Floor Space – Side</b>      | <ul style="list-style-type: none"> <li>1525 mm wide × 915 mm deep</li> </ul>                       | <ul style="list-style-type: none"> <li>One side unobstructed, adjoining accessible route</li> </ul>                                       |
| <b>Knee Clearance</b>                | <ul style="list-style-type: none"> <li>760 mm wide × 450 mm deep × 735 mm high</li> </ul>          | <ul style="list-style-type: none"> <li>Measured above finished floor</li> </ul>   |
| <b>Toe Clearance</b>                 | <ul style="list-style-type: none"> <li>350 mm high × 300 mm deep min</li> </ul>                    | <ul style="list-style-type: none"> <li>Depth at least 700 mm at foot of unit</li> </ul>   |
| <b>Operating Controls</b>            | <ul style="list-style-type: none"> <li>One-hand operation, ≤22 N force</li> </ul>                  | <ul style="list-style-type: none"> <li>No foot operation</li> <li>No twisting/pinching</li> <li>Automatic/hands-free preferred</li> </ul> |
| <b>Waterspout – Height</b>           | <ul style="list-style-type: none"> <li>≤915 mm from finished floor</li> </ul>                      | <ul style="list-style-type: none"> <li></li> </ul>  |
| <b>Waterspout – Location</b>         | <ul style="list-style-type: none"> <li>≤125 mm from front edge</li> </ul>                          | <ul style="list-style-type: none"> <li></li> </ul>  |
| <b>Waterspout – Flow</b>             | <ul style="list-style-type: none"> <li>≥100 mm high</li> </ul>                                     | <ul style="list-style-type: none"> <li>Angle: ≤30° if &lt;75 mm from front, ≤15° if 75–125 mm from front</li> </ul>                       |
| <b>Visual Contrast</b>               | <ul style="list-style-type: none"> <li>≥70% with adjacent surfaces</li> </ul>                      | <ul style="list-style-type: none"> <li>For easy identification</li> </ul>   |

## 2.11 Seating, Tables and Work Surfaces

### Rationale

Accessible seating, tables and work surfaces are essential for providing comfort and functionality to all individuals, including those with disabilities. Proper design ensures that these elements accommodate a wide range of users, promoting independence and inclusion.

### Application

This section applies to all seating, tables and work surfaces in both interior and exterior spaces, including but not limited to:

- Rest areas and accessible routes
- Dining facilities and food courts
- Waiting areas and lobbies
- Office and administrative environments
- Outdoor public areas (e.g., plazas, parks, transit stops)

### Design Requirements

#### Benches and Seats (Interior and Exterior)

Accessible seating provided in both interior and exterior environments must meet the following:

- Seat height: Between 450 mm and 500 mm above the finished floor/ground
- Seat depth: Between 460 mm and 510 mm, with a minimum seat width of 500 mm
- Back support: Extend 455 mm above the seat surface or affix to a wall for stability (see Figure 40)
- Armrests: At least one armrest provided, positioned between 220 mm and 300 mm above the seat surface. The armrest should be located opposite the transfer side; no armrest required on transfer side
- Clear floor space: At least 810 mm x 1370 mm adjacent to at least one seat/bench for mobility device transfer
- Stability: Benches and seats must be securely fixed and stable
- Visibility: Provide 70% colour contrast between seat surface and adjacent surroundings to assist with visibility
- Placement: Locate benches outside the clear width of accessible routes so they do not obstruct pedestrian travel

Note: For exterior benches provided as part of site furniture, see Section 4.7 Street Furniture for additional requirements related to durability, placement and environmental conditions.

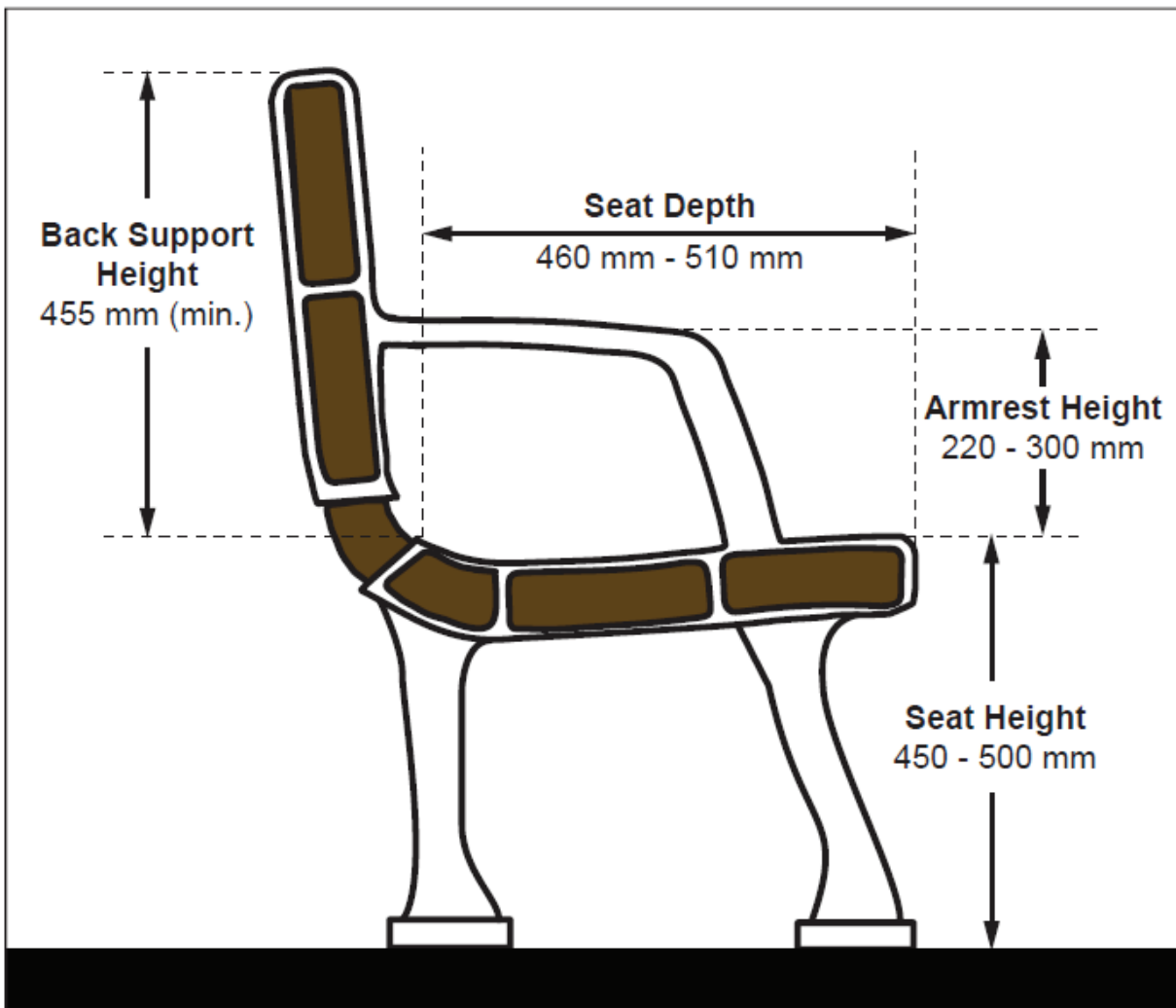

Figure 41: Typical Accessible Bench Dimensions – Section View

## Tables and Work Surfaces

Accessible tables and work surfaces must meet the following:

- Height: Between 730 mm and 865 mm above finished floor (see Figure 41a)
- Knee clearance: Minimum 915 mm wide by 685 mm high by 480 mm deep (see Figure 41a)
- Toe clearance: Minimum 350 mm high by 230 mm deep, where feasible
- Clear floor space:
  - Forward approach: 915 mm wide by 1370 mm deep (maximum 480 mm under table)
  - Side approach: 1525 mm wide by 915 mm deep (see Figure 42b)
- Surface visibility: Ensure colour contrast with adjacent surroundings

- Operability: Any hardware, attachments or mechanisms must comply with Section 5.1 Controls and Operating Mechanisms (e.g., one-hand use, no tight grasping, pinching or twisting)

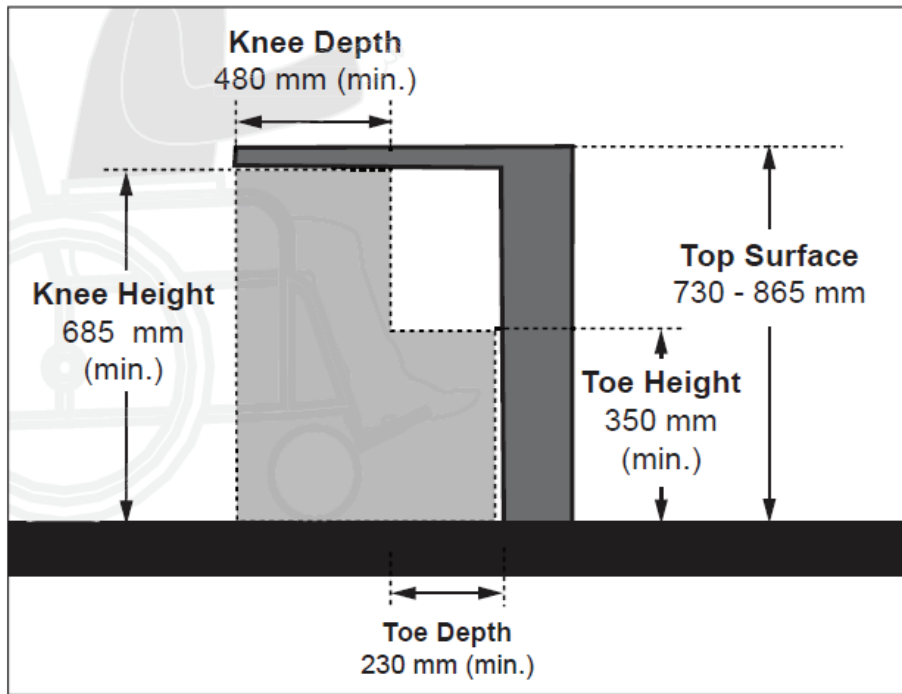

Figure 42: Knee and Toe Clearances at Tables or Work Surfaces – Elevation View

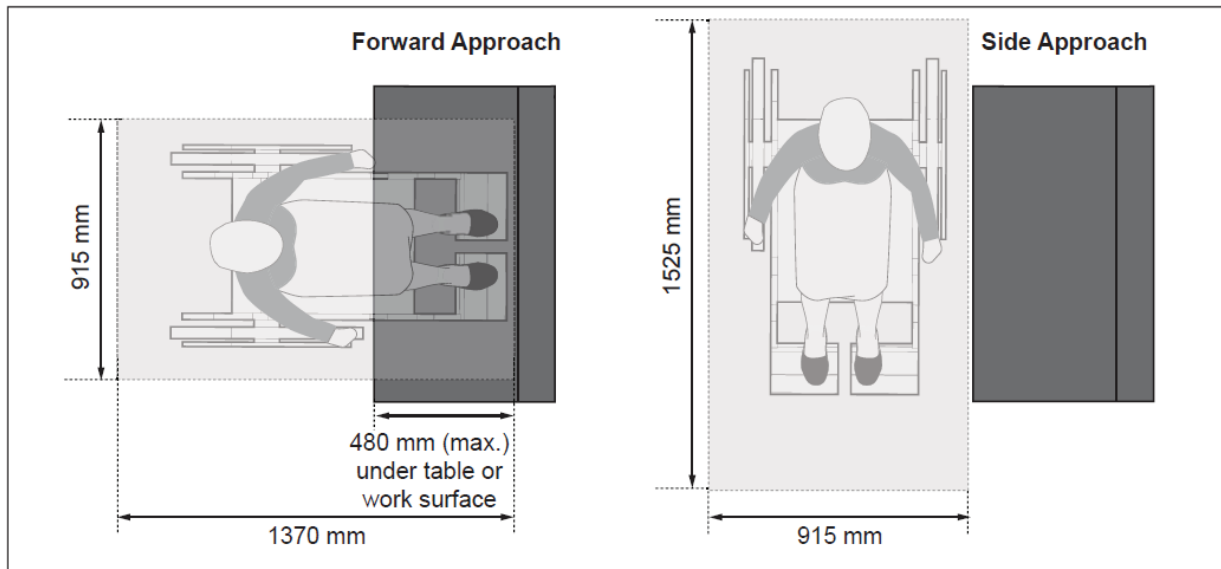

Figure 43: Clear Floor Space Requirements and Approach at Tables and Work Surfaces – Plan View

Table 15: Seating, Tables and Work Surfaces at a Glance

| Feature                                | Minimum / Recommended Dimensions   | Notes / Key Requirements  |
|--|--|---|
| <b>Benches &amp; Seats</b>             | <ul style="list-style-type: none"> <li>• Seat height: 450–500 mm AFF</li> <li>• Seat depth: 460–510 mm</li> <li>• Seat width: ≥500 mm</li> </ul> | <ul style="list-style-type: none"> <li>• Provide at least one bench/seat with adjacent clear floor space 810 × 1370 mm</li> <li>• Stable, securely fixed</li> <li>• Provide ≥70% colour contrast with surroundings</li> </ul> |
| <b>Back Support</b>                    | <ul style="list-style-type: none"> <li>• Extend ≥455 mm above seat surface</li> </ul>  | <ul style="list-style-type: none"> <li>• May be affixed to wall or free-standing back support</li> </ul>  |
| <b>Armrests</b>                        | <ul style="list-style-type: none"> <li>• Height: 220–300 mm above seat surface</li> </ul>  | <ul style="list-style-type: none"> <li>• Provide at least one armrest</li> <li>• None required on transfer side</li> </ul>  |
| <b>Clear Floor Space (for benches)</b> | <ul style="list-style-type: none"> <li>• 810 × 1370 mm minimum</li> </ul>  | <ul style="list-style-type: none"> <li>• Allows forward or parallel approach for mobility device transfer</li> </ul>  |
| <b>Tables / Work Surfaces – Height</b> | <ul style="list-style-type: none"> <li>• 730–865 mm AFF</li> </ul>   | <ul style="list-style-type: none"> <li>• Consistent across interior and exterior environments</li> </ul>  |
| <b>Knee Clearance</b>                  | <ul style="list-style-type: none"> <li>• Width: 915 mm</li> <li>• Height: 685 mm</li> <li>• Depth: 480 mm</li> </ul>                             | <ul style="list-style-type: none"> <li>• Provides space for forward approach</li> </ul>   |
| <b>Toe Clearance</b>                   | <ul style="list-style-type: none"> <li>• Height: ≥350 mm</li> <li>• Depth: ≥230 mm</li> </ul>  | <ul style="list-style-type: none"> <li>• Ensures comfortable access for mobility devices</li> </ul>   |
| <b>Clear Floor Space (for tables)</b>  | <ul style="list-style-type: none"> <li>• Forward: 915 × 1370 mm (max 480 mm under table)</li> <li>• Side: 1525 × 915 mm</li> </ul>               | <ul style="list-style-type: none"> <li>• Required at least at one accessible seating location per table grouping</li> </ul>   |
| <b>Surface Visibility</b>              | <ul style="list-style-type: none"> <li>• N/A</li> </ul>  | <ul style="list-style-type: none"> <li>• Table and bench surfaces must provide ≥70% colour/tonal contrast with adjacent surroundings</li> </ul>   |
| <b>Operability</b>                     | <ul style="list-style-type: none"> <li>• N/A</li> </ul>  | <ul style="list-style-type: none"> <li>• Any hardware or attachments must comply with Section 4.1 Controls &amp; Operating Mechanisms (usable with one hand, no tight grasping, pinching, or twisting)</li> </ul>             |

## 3.1 Entrances

### Rationale

Entrances are the first point of contact with a facility, and ensuring they are accessible is critical to providing equal access for all individuals. Accessible entrances facilitate ease of entry for everyone, including those with mobility impairments or other disabilities. By integrating accessible elements into the main entrance design, rather than separating accessible entrances, a facility fosters inclusivity and equality for all users. This approach contributes to a welcoming environment for everyone, promoting accessibility throughout the facility

### Application

This section applies to all entrances used by staff and/or the public, including any pathways leading to the entrance, the entrance components themselves, and areas between the exterior and interior environments (e.g., vestibules).

### Design Requirements

#### General

- **All entrances** intended for staff and/or public use must be accessible and comply with the requirements in this section
- At least one public entrance and one staff entrance must be equipped with a power door operator
- The main entrance must be located as close as possible to accessible parking and passenger loading zones
- In retrofit situations where it is technically infeasible to make all entrances accessible:
  - At least 50% of both staff and public entrances must comply with this section
  - The primary entrances used by staff and the public shall be accessible

#### Design and Layout

- Accessible entrances must be connected to an accessible route as defined in Section 3.3 Interior Paths of Travel
- Doors at accessible entrances must meet the criteria in Section 3.2 Doors and Doorways
- For entrances with multiple doors, only one door needs to be accessible
- For entrance vestibules:
  - Ensure there is a 2500 mm clear turning circle plus the width of the door swing (See Figure 42)

- Install power door operators on all vestibule doors
- Accessible entrances should be equipped with a power door operator and marked with the International Symbol of Accessibility

## Signage and Identification

Entrances must be equipped with signage that:

- Identifies an accessible entrance
- If an entrance is not accessible, signage should direct users to the nearest accessible entrance
- Complies with Section 5.9 Signage and Wayfinding

## Other Access Points

- If there is direct access from an enclosed parking garage, at least one accessible must be available from the garage
- If the only entrance is a service entrance, it must be accessible
- For pedestrian access tunnels, walkways or pedestrian bridges, at least one accessible entrance should be available from each access point

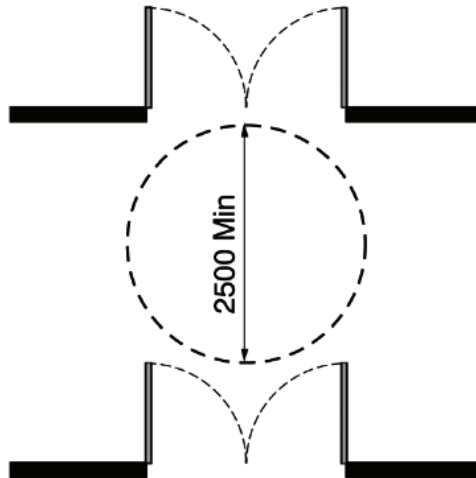

Figure 44: Entrance Vestibule

Table 16 – Entrances at a Glance

| Feature                      | Minimum / Recommended Dimensions  | Notes / Key Requirements  |
|------------------------------|---|---|
| <b>General Accessibility</b> | <ul style="list-style-type: none"> <li>All staff and public entrances</li> </ul>  | <ul style="list-style-type: none"> <li>Must comply with this section</li> </ul>   |
| <b>Power Door Operators</b>  | <ul style="list-style-type: none"> <li>At least 1 public + 1 staff entrance</li> </ul>  | <ul style="list-style-type: none"> <li>Main entrance and vestibule doors must have operators</li> </ul>                     |
| <b>Proximity</b>             | <ul style="list-style-type: none"> <li>Main entrance close to accessible parking &amp; loading zones</li> </ul>                                   | <ul style="list-style-type: none"> <li>Prioritize primary entrances</li> </ul>  |
| <b>Retrofit Allowance</b>    | <ul style="list-style-type: none"> <li>≥50% of staff + public entrances accessible</li> </ul>   | <ul style="list-style-type: none"> <li>Primary staff + public entrances must be accessible</li> </ul>                       |
| <b>Accessible Route</b>      | <ul style="list-style-type: none"> <li>Must connect to Section 3.3 Interior Paths of Travel</li> </ul>  | <ul style="list-style-type: none"> <li>Includes pathways leading to entrances</li> </ul>                                    |
| <b>Doors</b>                 | <ul style="list-style-type: none"> <li>Must comply with Section 3.2 Doors &amp; Doorways</li> </ul>   | <ul style="list-style-type: none"> <li>Only one door in a set must be accessible</li> </ul>                                 |
| <b>Vestibules</b>            | <ul style="list-style-type: none"> <li>2500 mm clear turning circle + door swing</li> </ul>   | <ul style="list-style-type: none"> <li>Power operators required on all vestibule doors</li> </ul>                           |
| <b>Signage</b>               | <ul style="list-style-type: none"> <li>International Symbol of Accessibility</li> </ul>   | <ul style="list-style-type: none"> <li>Non-accessible entrances must provide directional signage per Section 5.9</li> </ul> |
| <b>Other Access Points</b>   | <ul style="list-style-type: none"> <li>At least 1 accessible route from parking garages, service entrances, tunnels, walkways, bridges</li> </ul> | <ul style="list-style-type: none"> <li>Service-only entrances must also be accessible</li> </ul>                            |

## 3.2 Doors and Doorways

### Rationale

Accessible doors are key to ensuring equal access for everyone, including individuals using wheelchairs, mobility aids, strollers or those carrying items. By designing doors that can be operated independently, we foster autonomy and dignity for all users. Where possible, eliminating doors altogether should be considered when physical or acoustic privacy is not required, simplifying the design and enhancing accessibility.

### Application

This section applies to all interior and exterior doors intended for staff and/or public use that connect accessible paths of travel. It also covers single doors, double doors and other entry points. If it is technically infeasible to make all doors accessible in a retrofit situation, at least one door per accessible space must comply with this section.

This section also applies to doors required under Section 5.6 Fire and Life Safety Systems.

**Prohibited:** Frameless glass doors and/or sidelights must not be used (except for where they are specifically required, such as a squash court).

**Exceptions:** Doors that do not require full user passage, such as shallow closets, may have a clear opening reduced to 510 mm minimum.

**Note:** Where physical or acoustic privacy is not required, it is important to consider the possibility of eliminating doors altogether.

### Design Requirements

#### Clear Width

- Doors and doorways should have a clear opening of at least 950 mm minimum, measured between the face of the door and the opposite door stop when the door is open at 90 degrees
- If it is technically infeasible to provide the required clear width, a minimum of 860 mm is acceptable in retrofit situations
- For double-leaf doors, one active leaf must provide a clear width suitable for all users, including those using mobility devices. This door should be clearly identified as the primary door
- If there is a projection into the clear width between 860 mm and 2030 mm above the floor, it must not extend more than 100 mm

## Approach Clearances at Doors

- Ensure adequate clear floor space in front of doors to allow independent access for all users, including those using mobility devices. The required space will vary based on the type of door, approach (side or front) and whether the door is pushed or pulled
- For doors without a power door operator, clear space must be provided beside the latch, as described in Table 17
- The required clear space beside the latch must be unobstructed for the full height of the door
- The minimum space between two hinged or pivoted doors in series must be 1525 mm, plus the width of any door swinging into the space
- Where doors in a series do not align, a turn circle of at least 1525 mm must be provided within the vestibule area, clear of any door swing. (See figure 48)
- **Exception:** Clear space is not required on the inactive side of a door, such as in closets where access is provided from only one side

**Table 17: Manoeuvring Space at Doors**

| Context  | Floor space required (in mm) |               |                    |
|--|------------------------------|---------------|--------------------|
|  | Depth                        | Width         | Space Beside Latch |
| <b>Side-hinged door - Front approach (Figure 4.1.6.3)</b>  |                              |               |                    |
| Pull side  | 1525                         | 1600<br>*1525 | 600                |
| Push side  | 1370                         | 1250<br>*1220 | 300                |
| <b>Side-hinged door - Latch-side approach (Figure 4.1.6.2)</b>   |                              |               |                    |
| Pull side  | 1370<br>*1220                | 1600<br>*1525 | 600                |
| Push side  | 1370<br>*1100                | 1525          | 600                |
| <b>Side-hinged door - Hinge-side approach (Figure 4.1.6.1)</b>   |                              |               |                    |
| Pull side  | 2440<br>*1525                | 2440<br>*1525 | 600                |
| Push side  | 1370<br>*1100                | 1830          | 450                |
| <b>Sliding door (Figure 4.1.6.4)</b>   |                              |               |                    |
| Front Approach   | 1370                         | 1550          | 300                |
| Side Approach  | 1370<br>*1100                | 2150          | 600                |
| Note: In retrofit situations where it is technically infeasible to provide the required clearances at doors, the clearances may be reduced as shown by the asterisk (*). |                              |               |                    |

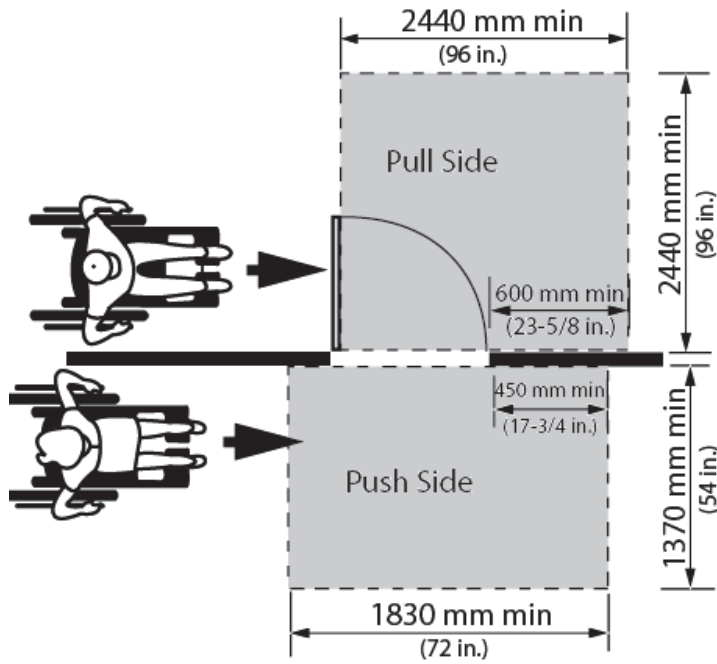

Figure 45: Hinge Side Approach at Hinged Doors

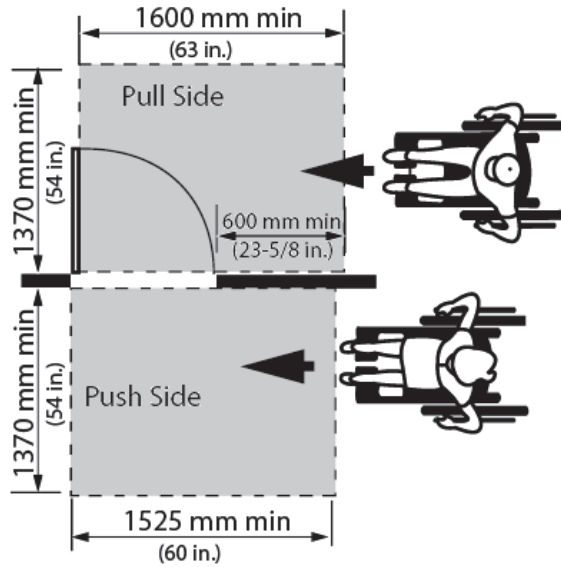

Figure 46: Latch Side Approach at Hinged Doors

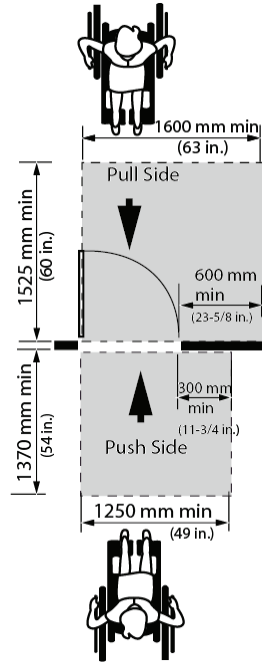

Figure 47: Front Approach at Hinged Doors

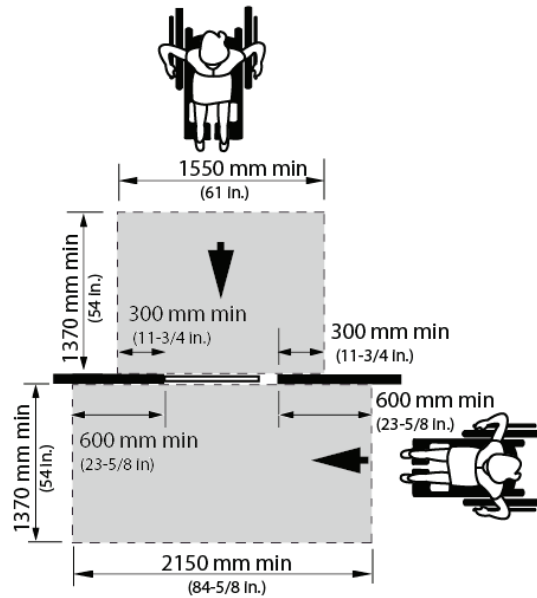

Figure 48: Front and Side Approach at Sliding Doors

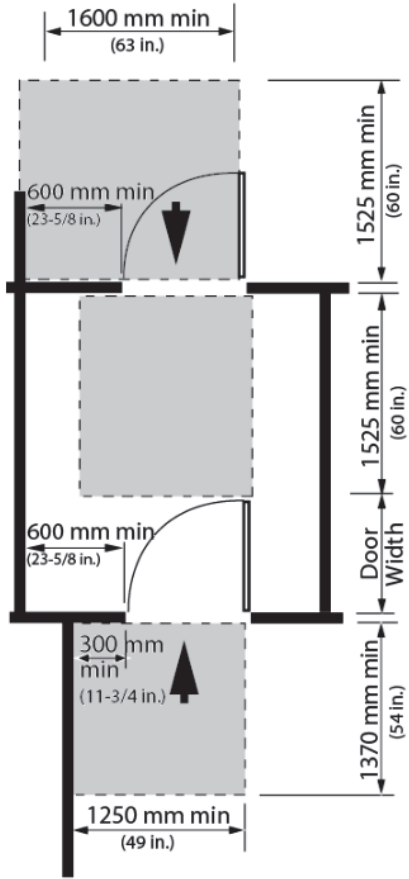

Figure 49: Manoeuvring Space at Doors in Series

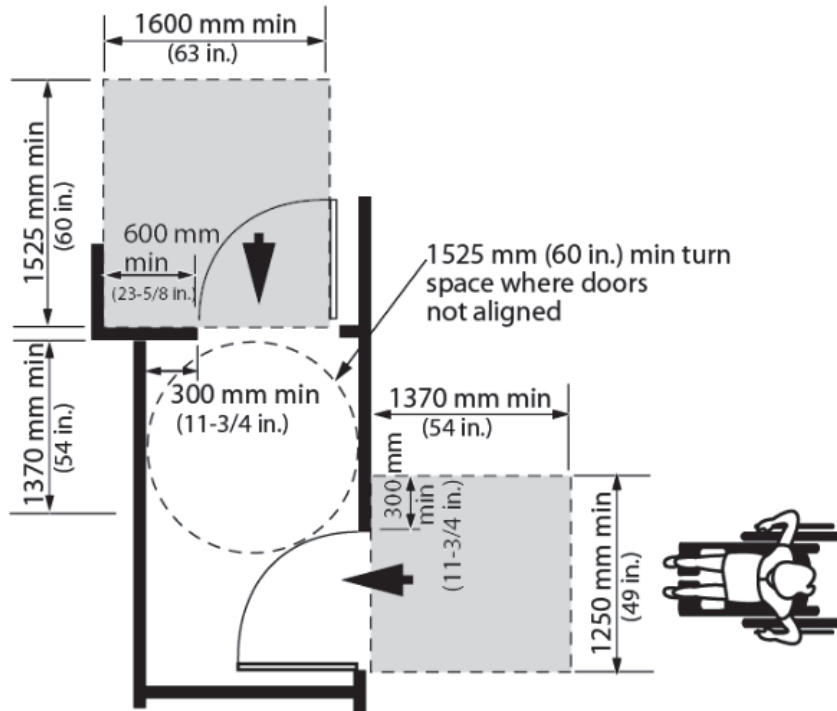

Figure 50: Manoeuvring Space at Doors in Series

## Thresholds

- Threshold at doorways should be no higher than 13 mm
- If the transition is over 6 mm, provide a bevel at a maximum slope of 1:2 (50%)

## Door Hardware

- Door hardware must be operable with a closed fist
- Hardware should not require fine finger control, pinching or wrist twisting
- The hardware should be mounted 900 mm to 1100 mm from the floor and provide at least 70% colour contrast (where possible) to the door
- Kick plates should be installed on doors in high-use areas to protect the push side from damage and make doors easier to open
- Panic hardware (push door release) should be installed on emergency exit doors

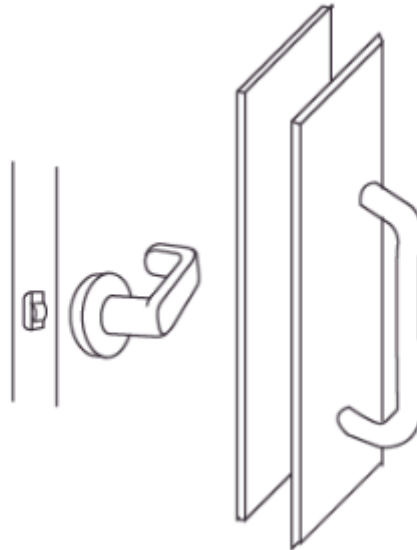

Figure 51: Examples of Accessible Hardware

## Colour Contrast of Doors and Frames

- Doors and their frames should have a minimum 70% colour contrast (where possible) to the adjacent walls and surfaces to improve visibility for individuals with low vision

## Operating Force and Closers

- The maximum opening force for pushing or pulling open a door should not exceed:
  - 38 N (8.5 lb.) for exterior hinged doors
  - 22 N (4.6 lb.) for interior hinged doors
  - 22 N (4.6 lb.) for sliding or folding doors

- Door closers must be adjusted to use the least amount of pressure possible, but not exceed the maximum opening forces listed
- The sweep period of closers should be adjusted so that the door takes at least three (3) seconds to move from a 90-degree open position to a position of 12 degrees from the latch

## Vision Panels

When used, vision panels at doors must:

- Have a minimum width of 75 mm
- Have the bottom edge of the panel (sill) at a maximum height of 900 mm A.F.F.
- Have the vertical edge closest to the latch located no more than 250 mm from the latch side of the door

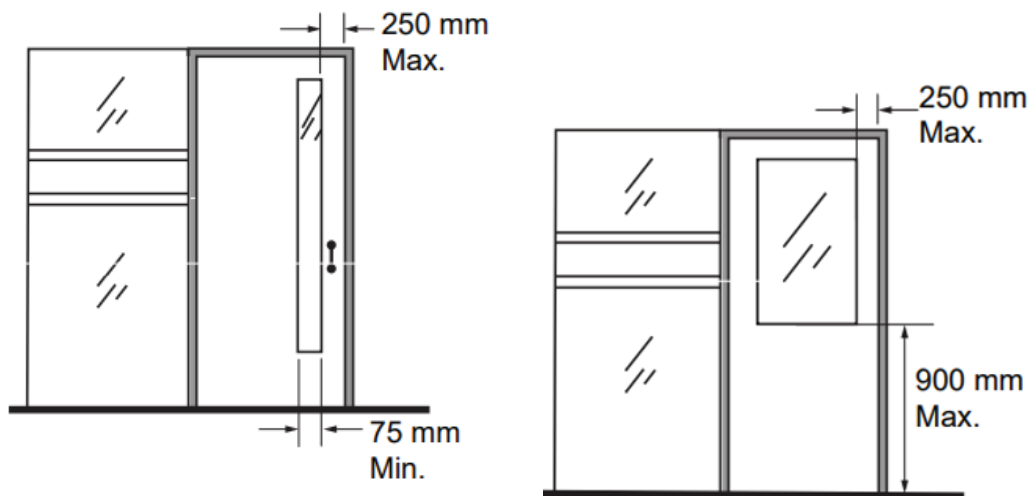

Figure 52: Vision panels

## Glass Doors and Vision Strips

For fully glazed doors, sidelights or panels, vision strips are required to increase visibility for individuals with low vision.

Vision strips must:

- Be located at:
  - Etched or patterned glazed screens
  - Fully glazed transparent doors
  - Sidelights/panels with widths greater than 300 mm
- Have two continuous opaque strips (can incorporate a decal or logo):
  - Located at 1350 mm to 1500 mm A.F.F and at 750 mm to 950 mm A.F.F

- Span across the full length of the glazed area
- Minimum of 50 mm wide
- Provide a minimum 70% colour/tonal contrast to the background of the surface

## Automatic Doors

When automatic doors are provided, they must:

- Have sensors placed to detect users approaching (if using pressure mats, ensure they can detect individuals using mobility devices)
- Open and close safely and smoothly, with mechanisms to prevent collisions or entrapment
- Ensure the door remains fully open for at least five seconds and close at a speed that allows safe passage
- Allow for partial opening or closing of the doors

## Power Door Operators

Power door operators increase the level of accessibility of a building, enabling all to navigate through. Power operators should be provided at the following locations:

- Building entrances, including public, staff and main entrances
- Along accessible paths, except for doors with electromagnetic hold-open devices
- All accessible washrooms (both multiple occupancy and universal washrooms) and change rooms
- 50% of each type of public meeting room in a facility, rounded up to the nearest whole number
- 10% of all staff utilized meeting rooms
- Doors entering public accessed reception areas
- Doors leading into an area of refuge

## Placement

Where power-assisted doors are provided, they must:

- Be clearly marked with International Symbol of Accessibility
- Require a maximum of 66 N to stop door movement
- Open fully in no less than three (3) seconds
- Remain open for at least five (5) seconds

Power door operators must be:

- Clearly visible on the push and pull side of the door and located on the latch side of the door
- Located at least 600 mm from any inside corner

- Where the door opens towards the user, the controls must be located not less than 600 mm and not more than 1525 mm beyond the door swing
- Incorporate controls that are:
  - Minimum 150 mm in diameter when circular, located with its centre between 1000 - 1100 mm A.F.F. or
  - Minimum 150 mm wide by a minimum 915 mm long when it is a vertical extended power door operator
  - Ensure colour contrast between the activation device and mounting surface (where possible)
- Where exterior doors swing open into a pedestrian area, incorporate safety guards that project a minimum of 300 mm beyond both sides of the open door (See Figure 51)

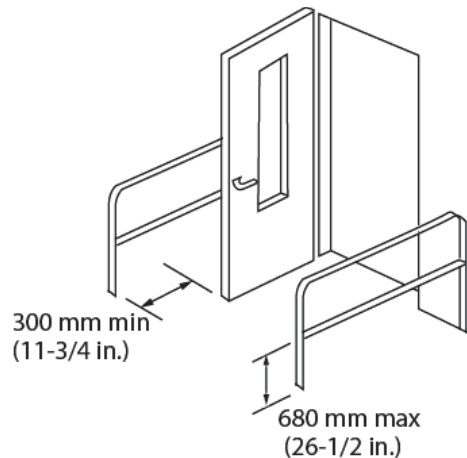

**Figure 53: Detectable Safety Guards**

## Revolving Doors and Turnstiles

- Revolving doors or turnstiles must have an adjacent accessible gate or door that meets a minimum clear width of 860 mm
- The accessible gate or door must be clearly marked with the International Symbol of Accessibility
- Automatic revolving doors should have mechanisms to slow or stop the door to avoid accidents caused by entrapment
- The revolving door must be large enough to accommodate a person using a mobility device and a support person

Table 18 – Doors and Doorways at a Glance

| Feature                             | Minimum / Recommended Dimensions   | Notes / Key Requirements   |
|-------------------------------------|--|--|
| <b>Clear Width</b>                  | <ul style="list-style-type: none"> <li>Preferred: <math>\geq 950</math> mm clear opening at <math>90^\circ</math> Retrofit min.: 860 mm</li> </ul>                                 | <ul style="list-style-type: none"> <li>For double doors, one active leaf must provide full clear width</li> <li>Projections 860–2030 mm A.F.F. must not extend <math>&gt;100</math> mm</li> </ul>  |
| <b>Thresholds</b>                   | <ul style="list-style-type: none"> <li>Max 13 mm height Bevel slope <math>\leq 1:2</math> if <math>&gt;6</math> mm</li> </ul>  | <ul style="list-style-type: none"> <li>Flush preferred</li> <li>Ensure no tripping hazards</li> </ul>  |
| <b>Approach Clearances</b>          | <ul style="list-style-type: none"> <li>Varies by approach/push/pull (see Table 17) Vestibule: <math>\geq 1525</math> mm clear + door swing</li> </ul>                              | <ul style="list-style-type: none"> <li>Retrofit allowances marked with * in Table 17</li> <li>Turning circle required if non-aligned doors</li> </ul>  |
| <b>Series Doors (Vestibules)</b>    | <ul style="list-style-type: none"> <li><math>\geq 1525</math> mm clear between doors + door swing</li> </ul>   | <ul style="list-style-type: none"> <li>Turning circle of <math>\geq 1525</math> mm if doors do not align</li> </ul>  |
| <b>Door Hardware</b>                | <ul style="list-style-type: none"> <li>Mount height: 900–1100 mm A.F.F.</li> </ul>   | <ul style="list-style-type: none"> <li>Operable with closed fist</li> <li>No twisting/pinching</li> <li><math>\geq 70\%</math> colour contrast (where possible)</li> <li>Kick plates at high-use doors</li> <li>Panic bars at exits</li> </ul> |
| <b>Operating Force</b>              | <ul style="list-style-type: none"> <li>Exterior hinged: <math>\leq 38</math> N</li> <li>Interior hinged/sliding: <math>\leq 22</math> N</li> </ul>                                 | <ul style="list-style-type: none"> <li>Closers: door must take <math>\geq 3</math> sec. to close from <math>90^\circ</math> to <math>12^\circ</math></li> </ul>  |
| <b>Vision Panels</b>                | <ul style="list-style-type: none"> <li>Width <math>\geq 75</math> mm Sill <math>\leq 900</math> mm A.F.F.</li> </ul>   | <ul style="list-style-type: none"> <li>Must be <math>\leq 250</math> mm from latch edge</li> </ul>   |
| <b>Glazed Doors / Vision Strips</b> | <ul style="list-style-type: none"> <li>Two opaque strips 50 mm wide</li> <li>Located at 750–950 mm &amp; 1350–1500 mm A.F.F.</li> </ul>  | <ul style="list-style-type: none"> <li>Continuous across glazed area</li> <li><math>\geq 70\%</math> tonal contrast</li> </ul>   |
| <b>Automatic Doors</b>              | <ul style="list-style-type: none"> <li>Open <math>\geq 5</math> sec</li> <li>Close slowly/safely</li> </ul>  | <ul style="list-style-type: none"> <li>Sensors must detect mobility devices</li> <li>Partial opening allowed</li> </ul>  |
| <b>Power Door Operators</b>         | <ul style="list-style-type: none"> <li>Activation devices: 150 mm <math>\varnothing</math> circular or 150 × 915 mm vertical bar</li> <li>Centre at 1000–1100 mm A.F.F.</li> </ul> | <ul style="list-style-type: none"> <li>Must be located 600 mm from corners, colour-contrasted, clearly marked with ISA</li> <li>Exterior swing doors require 300 mm safety guards</li> </ul>   |

| <b>Feature</b>                      | <b>Minimum / Recommended Dimensions</b>  | <b>Notes / Key Requirements</b>   |
|-------------------------------------|--|---|
| <b>Revolving Doors / Turnstiles</b> | <ul style="list-style-type: none"><li>• Adjacent accessible gate/door <math>\geq 860</math> mm clear width</li></ul> | <ul style="list-style-type: none"><li>• Must be ISA-marked</li><li>• Revolving doors must slow/stop to avoid entrapment</li></ul> |

## 3.3 Interior Accessible Routes

### Rationale

Interior accessible routes are essential to ensuring equal access for everyone. They provide a continuous, unobstructed route that allows users with mobility devices, strollers, or those travelling in pairs to independently navigate through buildings. These paths should ensure safe, easy access to key areas such as restrooms, workstations, meeting rooms, and public spaces, while fostering inclusivity in interior design.

### Application

The scope of this section applies to interior aisles, corridors, hallways and other pedestrian circulation paths within a facility. It also applies to connections between buildings such as walkways or pedestrian bridges, unless identified as exceptions.

For paths involving changes in elevation, such as ramps or stairs, accessible routes may include elements like ramps, elevators or other assistive elevating devices.

### Exceptions

The following areas do not require accessible paths of travel:

- Service rooms
- Elevator machine rooms
- Janitor rooms
- Service spaces
- Crawl spaces
- Attic or roof spaces
- High-hazard industrial occupancies
- Portions of floors with fixed seating in assembly occupancies (unless directly related to spaces designated for mobility device use)
- Suite of residential occupancies

## Design Guidelines

### General Features

- Ensure ground surfaces are firm, stable and slip-resistant
- Provide headroom clearance of at least 2100 mm
  - Where clearance is less than 2100 mm, provide guards to protect users from potential hazards
- Maintain a lighting level of 50 lux (5 foot-candles), measured at ground level (refer to Section 5.8 Lighting)
- Where possible, provide colour contrast of at least 70% to distinguish the edges of interior accessible paths of travel for improved wayfinding
- Install signage and wayfinding cues along accessible routes, including entrances and exits, with clear visual information that contrasts with its background
- Rest areas should be provided at intervals of no more than 30 metres along interior accessible routes

### Clear Width

Accessible paths must have clear widths, from obstructions, protrusions and overhead objects that allow safe passage, as follows:

- **Primary accessible path:** 1830 mm (Figure 54)
- **Secondary accessible path:** 1370 mm (Figure 55)
- **Other routes:** 1100 mm (Figure 56)
- **Between furniture or workstations:** 920 mm

Ensure clear space beside doors, as specified in Section 3.2 Doors and Doorways

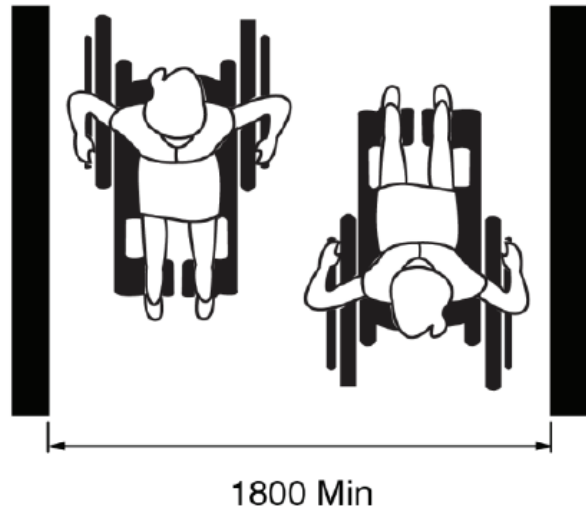

Figure 54: Primary Accessible Path

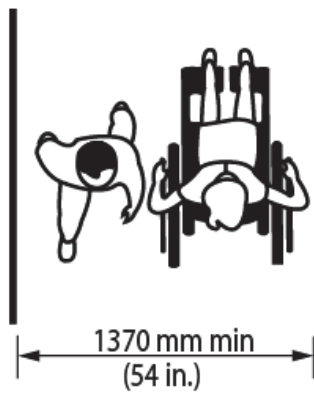

Figure 55: Secondary Accessible Path

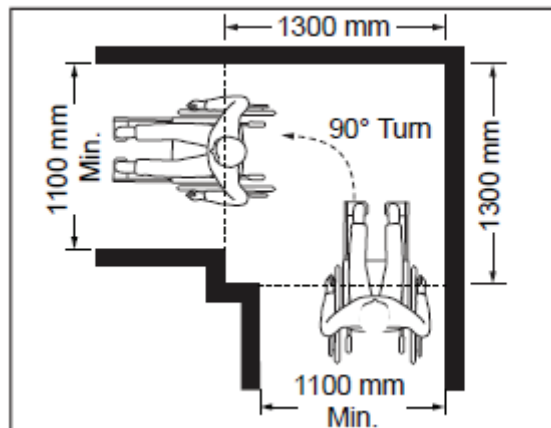

Figure 56: Minimum Width of Other Routes

## Clear turning spaces

Interior accessible paths should include clear turning spaces:

- For 90 degree turns (Figure 57) are:
  - 1300 mm in diameter (minimum)
  - 1500 mm in diameter (preferred)
- For 180 degree turns:
  - Are 2000 mm in the direction of travel and at least 1500 mm wide (Figure 58 and Figure 59)
  - Are 1220 mm around an obstacle that is less than 1220 mm wide (Figure 60)
- For 360 degree turns and dead-end areas:
  - Minimum 2500 mm in diameter (Figure 61)



**Figure 57: Space Required for a 90° Turn**

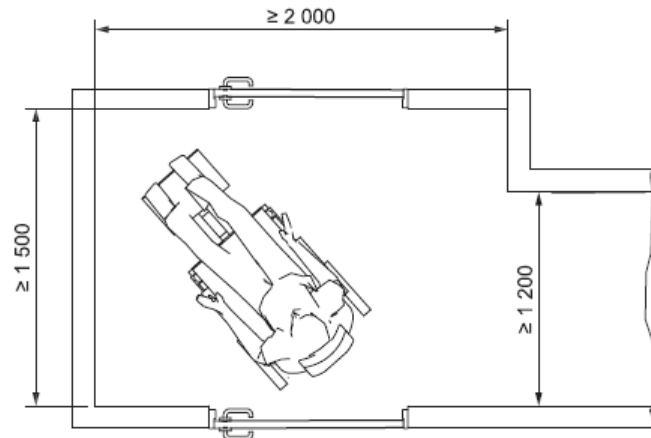

**Figure 58: Space Required for a 180° Turn in a Corridor**

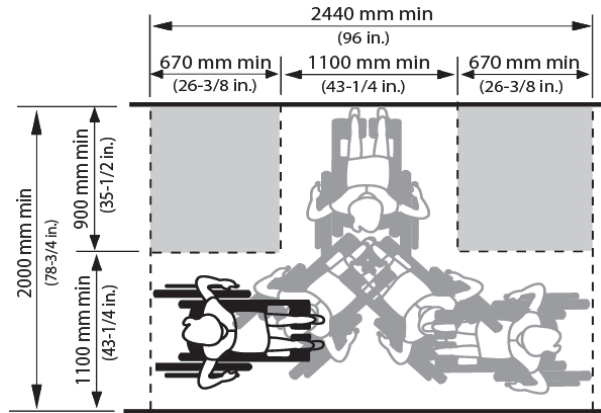

**Figure 59: 180° Degree Turning Space**

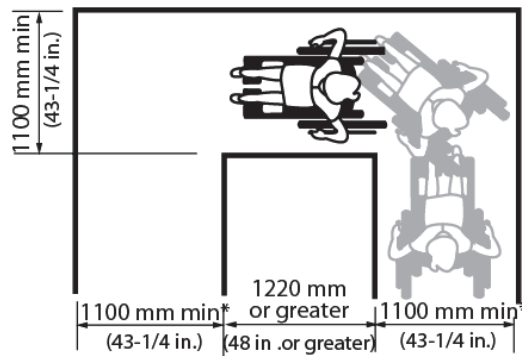

**Figure 60: Turn Around an Obstacle Greater than 1200 mm Wide**

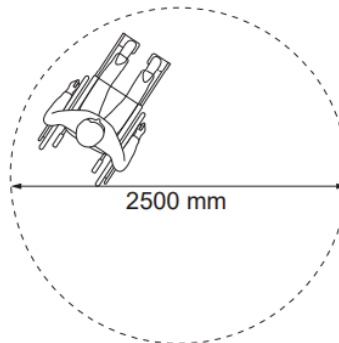

**Figure 61: 360° Turning Space**

## Passing Areas

Passing areas should be:

- Unobstructed
- 1800 mm by 1800 mm in size
- Located at:
  - The beginning and end of corridors

- 30 m intervals along corridors

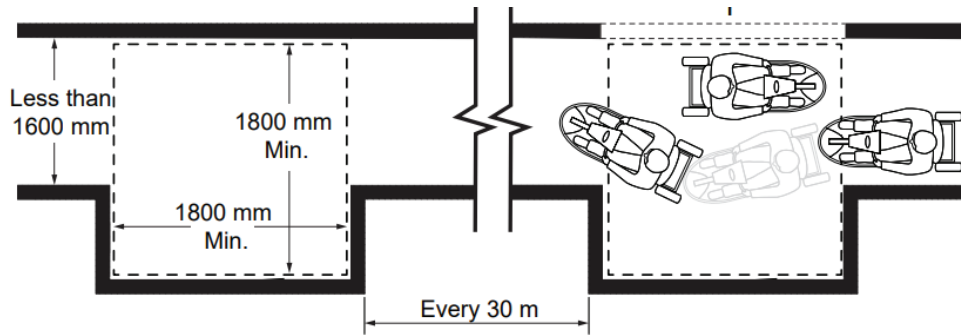

Figure 62: Passing Areas

## Running and cross slopes

The slopes of interior accessible paths must comply with the following:

- **Running slope:** Maximum 1:20 (5%)
- **Cross slope:** Maximum 1:50 (2%)
- **Ramps:** Paths with a running slope greater than 1:20 (5%) must be designed as ramps and meet criteria in Section 2.3 Ramps



Figure 63: Running Slope

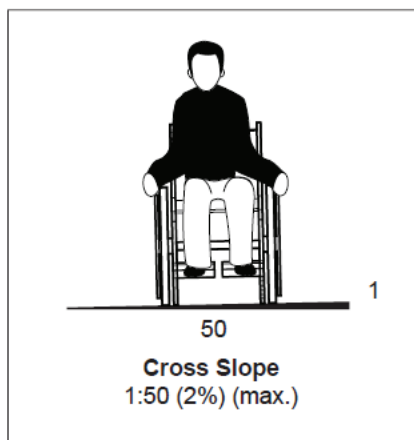

**Figure 64: Cross Slope**

**Table 19 – Interior Paths of Travel at a Glance**

| Feature                      | Minimum / Recommended Dimensions  | Notes / Key Requirements  |
|------------------------------|---|---|
| <b>Surface &amp; Safety</b>  | <ul style="list-style-type: none"> <li>Firm, stable, slip-resistant</li> </ul>  | <ul style="list-style-type: none"> <li>Lighting <math>\geq 50</math> lux at ground</li> <li>70% contrast at path edges</li> <li>Headroom <math>\geq 2100</math> mm (guards required if less)</li> </ul> |
| <b>Clear Widths</b>          | <ul style="list-style-type: none"> <li>Primary path: 1830 mm</li> <li>Secondary path: 1370 mm</li> <li>Other routes: 1100 mm</li> <li>Between furniture/workstations: 920 mm</li> </ul>   | <ul style="list-style-type: none"> <li>Must remain free of obstructions/protrusions</li> <li>Clearances beside doors per Section 3.2</li> </ul>   |
| <b>Turning Spaces</b>        | <ul style="list-style-type: none"> <li>90° turns: 1300 mm <math>\varnothing</math> (min)</li> <li>1500 mm <math>\varnothing</math> (preferred)</li> <li>180° turns: 2000 mm long <math>\times</math> 1500 mm wide</li> <li>Around narrow obstacle: 1220 mm <math>\varnothing</math></li> <li>360°/dead end: 2500 mm <math>\varnothing</math></li> </ul> | <ul style="list-style-type: none"> <li>Turning spaces must be level, clear of obstacles</li> </ul>  |
| <b>Passing Areas</b>         | <ul style="list-style-type: none"> <li>1800 mm <math>\times</math> 1800 mm</li> </ul>   | <ul style="list-style-type: none"> <li>At corridor ends, and at 30 m intervals</li> </ul>   |
| <b>Slopes</b>                | <ul style="list-style-type: none"> <li>Running slope: <math>\leq 1:20</math> (5%)</li> <li>Cross slope: <math>\leq 1:50</math> (2%)</li> </ul>  | <ul style="list-style-type: none"> <li>Paths <math>&gt; 1:20</math> must meet ramp requirements (Section 2.3)</li> </ul>  |
| <b>Wayfinding &amp; Rest</b> | <ul style="list-style-type: none"> <li>Rest areas every <math>\leq 30</math> m</li> <li>Clear signage/wayfinding</li> </ul>   | <ul style="list-style-type: none"> <li>Visual contrast, consistent cues</li> <li>Signage per Section 5.9</li> </ul>   |

## 3.4 Millwork, Storage and Shelving

### Rationale

Millwork includes fixed storage such as cabinets, closets, shelves and drawers. Designs must address lower reach ranges and sightlines for children and persons using mobility devices and include visual contrast for low-vision users.

### Application

If fixed or built-in storage units, such as cabinets, closets, shelves and drawers are provided, at least one of each type must be accessible.

Self-service shelving or display units must be on an *accessible route* complying with Section 3.3 Interior Accessible Routes.

### Requirements

#### Reach and Mounting Heights

- Provide clear floor space at least 810 mm by 1370 mm for a forward or parallel approach, complying with Section 2.1 Space and Reach Requirements
- Where provided, mount collapsible coat hooks or closet rods at 1100-1200 mm A.F.F.
- Provide shelves between 230 mm and 1100 mm A.F.F. for accessible use
  - Upper storage shelves (not intended for accessible use) may be installed up to 1370 mm AFF as shown in Figure 65)
- In closets without accessible doors where the user's reach is offset 255-535 mm, set rods or shelves at 1200 mm max A.F.F.

#### Hardware and Operability

- Provide touch latches and U-shaped pulls or equivalent easy-grip hardware
- Operable parts must comply with Section 5.1 Controls and Operating Mechanisms and be usable with one hand without tight grasping, pinching or twisting
- Do not locate hooks above benches
- Ensure door hardware is mounted between 900-1100 A.F.F.

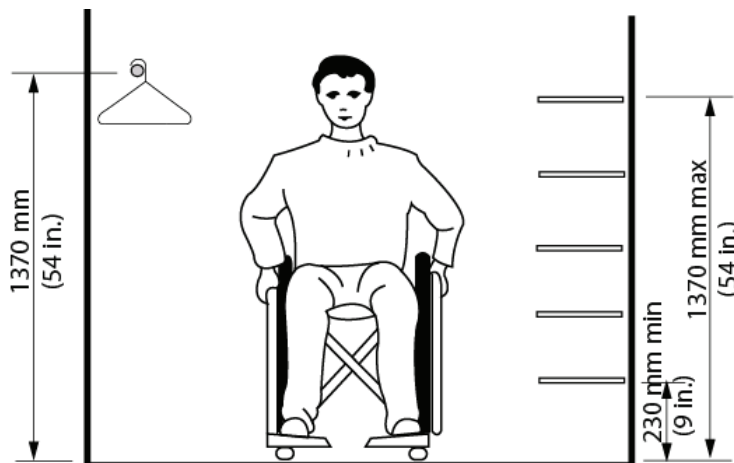

Figure 65: Reach Limits for Storage

Table 55: Millwork, Storage and Shelving – At a Glance

| Feature  | Minimum/Recommended Dimensions   | Notes / Key Requirements   |
|--|--|--|
| <b>Clear floor space</b>                         | <ul style="list-style-type: none"> <li>810 × 1370 mm minimum</li> </ul>        | <ul style="list-style-type: none"> <li>Forward or parallel approach</li> <li>Must comply with Section 2.1 Space and Reach Requirements</li> </ul>  |
| <b>Coat hooks / closet rods</b>                  | <ul style="list-style-type: none"> <li>1100–1200 mm A.F.F.</li> </ul>          | <ul style="list-style-type: none"> <li>Must be collapsible</li> <li>Do not locate hooks above benches</li> </ul>   |
| <b>Shelves (accessible band)</b>                 | <ul style="list-style-type: none"> <li>230–1100 mm A.F.F.</li> </ul>           | <ul style="list-style-type: none"> <li>At least one accessible shelf per storage type</li> </ul>   |
| <b>Closets with offset reach (255–535 mm)</b>    | <ul style="list-style-type: none"> <li>Rods/shelves ≤1200 mm A.F.F.</li> </ul> | <ul style="list-style-type: none"> <li>Applies where closet doors or obstructions limit access</li> </ul>  |
| <b>Hardware</b>                                  | <ul style="list-style-type: none"> <li>N/A</li> </ul>                          | <ul style="list-style-type: none"> <li>Touch latches or U-shaped pulls</li> <li>Operable one-handed without tight grasping, pinching, or twisting</li> <li>Must comply with Section 5.1 Controls and Operating Mechanisms</li> </ul> |
| <b>Accessible route to self-service shelving</b> | <ul style="list-style-type: none"> <li>N/A</li> </ul>                          | <ul style="list-style-type: none"> <li>Must be located on an accessible route per Section 3.3 Interior Accessible Routes</li> </ul>  |

## 3.5 Windows and Glazing

### Rationale

Windows should provide clear views for seated and standing users and be easy and safe to operate. Poorly placed or hard-to-use windows can create barriers for people using mobility devices, people of shorter stature, or those with limited dexterity. Safety markings on large, glazed surfaces reduce the risk of accidental collisions, especially for people with low vision.

### Application

Applies to all windows, glazed screens, sidelights, and vision panels in doors that are intended for viewing or ventilation. Frameless glass doors and sidelights are not permitted.

### Design requirements

#### Sill height

Windows must:

- Have sills mounted at a height of 760 mm maximum A.F.F. to allow clear views from a seated position
- Have lower edge of glazing that aligns with the sill height to provide an unrestricted view

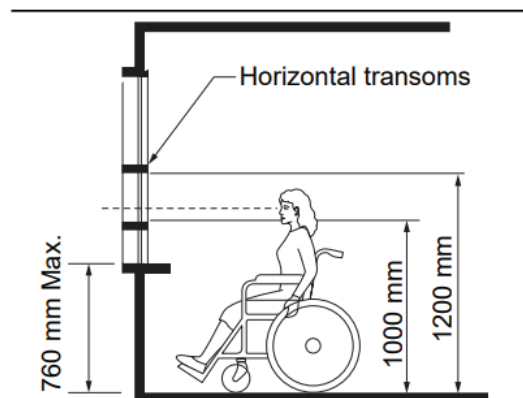

Figure 66: Window Sill Height

#### Transoms and Sightlines

Where horizontal transoms are provided at windows, they should:

- Avoid horizontal transoms within common eye level (1060 mm and 1220 mm A.F.F.)
- Maintain unobstructed sightlines where glazing is intended for viewing
- Have colour/brightness contrast from adjacent surfaces

## Window Hardware

- Mount handles, pulls latches and locks between 400 mm and 1200 mm A.F.F.
- Ensure operability with one hand, without tight grasping, pinching or twisting

## Vision Strips

To ensure safety and accessibility, vision strips must be applied to all large, glazed surfaces where people could accidentally walk into them, including:

- Fully glazed transparent doors
- Fully glazed transparent sidelights and panels with widths greater than 300 mm
- Glazed screens and partitions in circulation areas (e.g., atriums, lobbies, corridors)

Vision strips must:

- Consist of two continuous opaque strips (can incorporate a decal or logo)
- Be located at 1350 mm to 1500 mm A.F.F and at 750 mm to 950 mm A.F.F
- Extend across the full length of the glazed area
- Be at least 50 mm wide
- Provide a minimum 70% colour/tonal contrast with the background surface

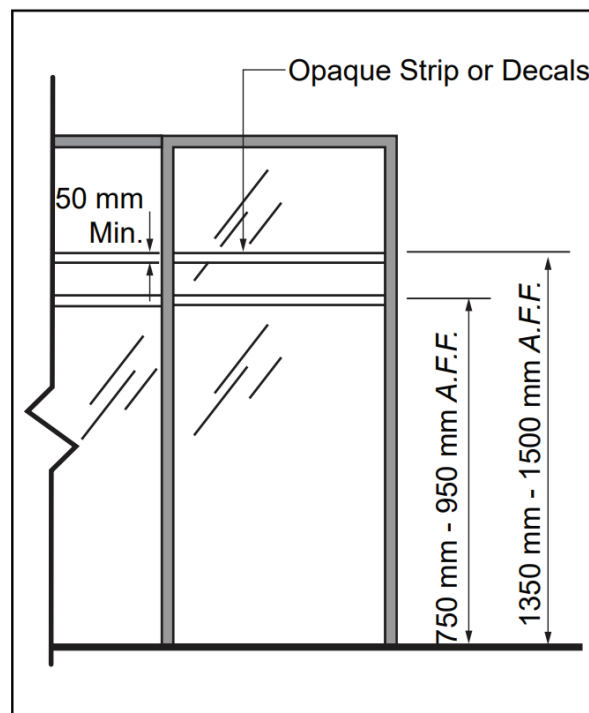

**Figure 67: Vision Strips**

Table 56: Windows and Glazing – At a Glance

| Feature                                | Minimum / Recommended Dimensions   | Notes / Key Requirements   |
|--|--|--|
| <b>Sill Height &amp; Views</b>         | <ul style="list-style-type: none"> <li>Sill ≤760 mm A.F.F.</li> </ul>  | <ul style="list-style-type: none"> <li>Allows clear views from seated position</li> <li>Glazing must align with sill for unobstructed sightlines</li> </ul>  |
| <b>Transoms &amp; Sightlines</b>       | <ul style="list-style-type: none"> <li>Avoid transoms between 1060–1220 mm A.F.F.</li> </ul>   | <ul style="list-style-type: none"> <li>Maintain unobstructed views</li> <li>Provide colour/brightness contrast from adjacent surfaces</li> </ul>   |
| <b>Hardware &amp; Operability</b>      | <ul style="list-style-type: none"> <li>400–1200 mm A.F.F.</li> </ul>   | <ul style="list-style-type: none"> <li>Handles, pulls, latches operable with one hand</li> <li>No tight grasping, pinching, twisting</li> </ul>  |
| <b>Vision Strips (safety markings)</b> | <ul style="list-style-type: none"> <li>Two continuous opaque strips</li> <li>Located at 750–950 mm A.F.F. and 1350–1500 mm A.F.F.</li> <li>Minimum 50 mm wide</li> </ul> | <ul style="list-style-type: none"> <li>Required on fully glazed doors, sidelights (&gt;300 mm wide), glazed screens/partitions in circulation areas</li> <li>Must span full glazed area length</li> <li>Provide ≥70% tonal/colour contrast with background</li> <li>May incorporate decals or logos if full opacity/contrast maintained</li> </ul> |

## 3.6 Elevating Devices

### Rationale

Elevating devices are essential for providing accessible vertical transportation within buildings, ensuring that people with mobility impairments, including those using wheelchairs, scooters, or strollers, can move between floors. Proper design of these devices, including elevators, lifts, and escalators, is crucial to allow independent access for everyone. Ensuring the device is equipped with tactile, audible, and visual cues helps people with varying disabilities navigate safely and independently.

### Application

This section applies to all elevating devices in facilities, including:

- Elevators
- Platform lifts
- Inclined lifts
- Moving walkways
- Escalators

All passenger elevating devices must comply with the current Ontario building Code (OBC) and other applicable requirements identified in the most up-to-date versions of:

- CAN / CSA B44: Safety Code for Elevators and Escalators
- CAN / CSA B355: Lifts for Persons with Physical Disabilities
- CAN / CSA B651: Accessible Design for the Built Environment

Additionally, the Technical Standards and Safety Authority (TSSA) legislation will govern the installation and maintenance of elevating devices within Ontario.

### Exceptions

- Freight elevators do not need to comply unless they are used as combination passenger and freight elevators
- When retrofitting existing buildings, structural or physical constraints may be considered, and accessibility requirements should be reviewed on a case-by-case basis in consultation with Facilities & Property Management staff

## Requirements

### General features

- Accessible elevating devices must be located on an accessible route as per Section 3.3 Interior Accessible Routes
- Identification: All elevating devices must be identified with accessible signage, complying with Section 5.8 Signage and Wayfinding
- Automatic Levelling: Elevators must feature automatic levelling to maintain floor alignment within  $\pm 13$  mm
- Doors: Power-operated horizontally sliding car and landing doors must be provided

### Approach and access to the lift

- Tactile Features: Elevating device entrances should have tactile features, such as raised Arabic numerals and Braille floor designations on both jambs of the door. These should be a minimum of 50 mm high and raised at least 0.75 mm, positioned at  $1500 \pm 25$  mm from the floor
- Colour Contrast: The lift entrance door should contrast with the surrounding wall finishes to ensure visibility and assist in wayfinding
- Tactile Walking Surface Indicators (TWSIs): For larger buildings or wide halls, install TWSIs to identify lift entrances. In simpler buildings, provide a distinguishable floor surface in front of the lift entrance (1500 mm by 1500 mm minimum)
- Manoeuvring Space: The manoeuvring space in front of lift entrances must be at least 1500 mm by 1500 mm, except in exceptional cases, where a reduced space of 1200 mm by 1200 mm may be considered (Figure 66)

### Exceptional Considerations for Existing Buildings

- The minimum manoeuvring space may be reduced but must not be less than 1200 mm by 1200 mm
- **New TSSA Update:** The minimum distance to any adjacent corner or obstruction must be 2000 mm to allow safe manoeuvring

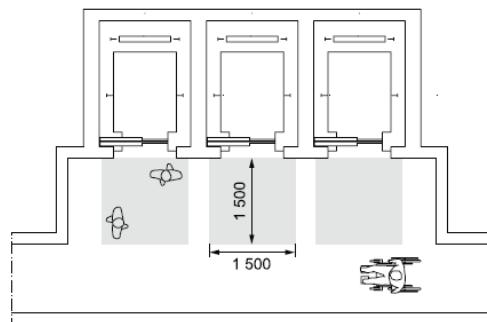

Figure 68: Manoeuvring space in front of a group of lifts

## Elevator Entrance

- Clear Width of Car Entrance:
  - Wheelchair-use: 950 mm minimum door width, 1100 mm wall-to-wall inside width, 1400 mm car length
  - Stretcher-use: 950 mm door width, 1100 mm wall-to-wall inside width, 2100 mm car length
  - For other facilities such as arenas or libraries, the car must be wider (e.g., 1065 mm door width, 1725 mm wall-to-wall inside width, 1525 mm car length)
- Elevator Car Dimensions: Refer to Table 57 for detailed specifications on different elevator types

**Table 57: Minimum Dimensions for Elevator Car and Door Clear Width**

| Elevator Type                                | Minimum Door Width (mm) | Door Location                         | Wall-to-Wall Inside Width (mm) | Door-to-Wall Inside Length (mm) |
|--|-------------------------|---------------------------------------|--------------------------------|---------------------------------|
| Wheelchair-use                               | 950                     | Centered – Narrow side                | 1100                           | 1400                            |
| Stretcher-use                                | 950                     | Centered – Narrow side                | 1100                           | 2100                            |
| Wheelchair-use<br>Doors on adjacent sides,   | 950                     | Two doors-adjacent sides              | 1400                           | 1600                            |
| High- Use Facilities                         | 1065                    | Side (Off-Center)                     | 1725                           | 1525                            |
| Arenas, libraries or entertainment complexes | 1065                    | Side (Off-Center)                     | 2030                           | 1525                            |
| Exceptional Situation – Retrofitting         | 950                     | one entrance or two on opposite sides | 1100                           | 1370                            |

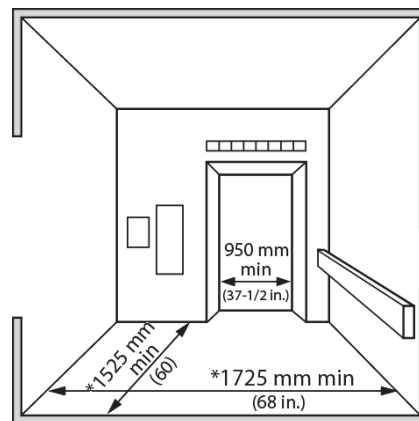

**Figure 69: Elevator Car Dimensions**

## Equipment in the car

- Handrails: Provide handrails on non-access walls at a height of 800 to 950 mm above the floor, preferably  $850 \pm 25$  mm, with a space of 40 to 45 mm between the rails and the wall
  - In retrofit situations, at least one handrail must be provided on the car's wall where the operating panel is located
- Seating: Where a foldable seat is provided, it must have:
  - A top height from the floor between 500 mm and 520 mm
  - A depth between 400 mm and 500 mm and a width of 500 mm to 600 mm
  - It should support a weight of up to 150 kg
- Floor and Wall Surfaces: Internal walls should be matte and non-reflective, with contrasting colours. The floor must be slip-resistant, and both the floor of the lift and the landing floors should have similar characteristics

## Lighting

- Lighting Level: Internal lighting must be uniformly distributed with a minimum illumination of 100 lux at the floor level and 200 lux on control devices. Avoid using spotlights to reduce glare

## Emergency Communication

- Alarm System: The car must have a two-way communication system for emergency situations that allows communication to a rescue service
  - The system must ensure both voice communication and visual feedback (green and yellow symbols) and provide text display for floor levels
  - The highest operable portion of the two-way communication system must be a maximum of 1200 mm above the floor and the symbol must be a minimum of 38 mm high raised at least 0.75 mm
- Handsets: The system must include a handset with a cord length of at least 735 mm, and the receiver must comply with CSA Standard T515

## Control Devices and Signals

- Button Design: Elevator control buttons should be tactile and provide visual contrast against the wall. They must be accompanied by Braille labels and have a minimum of 16 mm characters for easy reading
- Audible Signals: The system must provide a voice message indicating the current floor, direction of travel, and door operation status. In addition, visual and audible feedback should confirm when a button has been pressed

- Touchscreens: While allowed, touchscreens must include tactile control options for accessibility and should not be the only form of control

## Stopping/Levelling Accuracy

- The car should stop with an accuracy of  $\pm 10$  mm and the levelling accuracy should be within  $\pm 20$  mm

## Car Controls

Upon entering an elevator, the car controls should be easily accessible from a wheelchair.

- Car Position Indicator:
  - An indicator must be installed inside the car to display its position within the hoistway. This indicator will be illuminated to show the landing at which the car is either stopped or passing
  - Indication characters must be on a contrasting colour background and have a minimum of 16 mm height to ensure visibility for users with low vision
- Emergency Controls:
  - Emergency car controls and door-operating buttons must be grouped together at the bottom of the control panel
  - The centreline of the alarm button and the emergency stop switch must be not less than 890 mm above the floor, ensuring easy access for all users
  - The centreline of the highest floor button must be no higher than 1200 mm above the floor
- Floor Register Buttons:
  - Floor register buttons must:
    - Be a minimum of 19 mm in size and may be raised, flush, or recessed. The depth of flush or recessed buttons must not exceed 10 mm when operated
    - Be provided with visual and momentary audible indicators to show when each call is registered. These indicators must be extinguished when the call is answered
- Braille and Raised Markings:
  - All car control buttons must be designated with Grade 2 Braille characters and raised standard alphabet characters for letters, Arabic numerals for numbers, and standard symbols
  - Markings must be a minimum of 16 mm high and raised a minimum of 0.75 mm, placed immediately to the left of the buttons to which they apply

- **Exception:** For mechanical call buttons, the raised markings may be on the buttons themselves
- **Button Placement:**
  - Controls should be placed at a minimum distance of 400 mm (preferably 700 mm) from any corner to ensure users have adequate access space and avoid obstructions

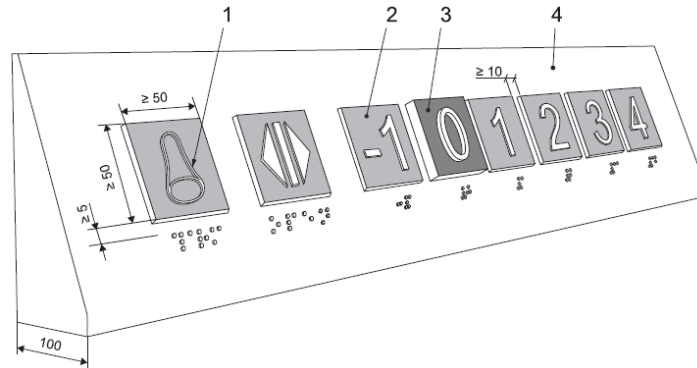

**Key**

1. Alarm bell as tactile symbol in yellow colour
2. Acquire 50 mm by 50 mm push button with visual contrast to the panel and the raised tactile character/symbol
3. Ground floor button with higher rise and different colour
4. Inclined surface

**Figure 70: Example of a Horizontal Arrangement of Square Push Buttons with Tactile Characters**

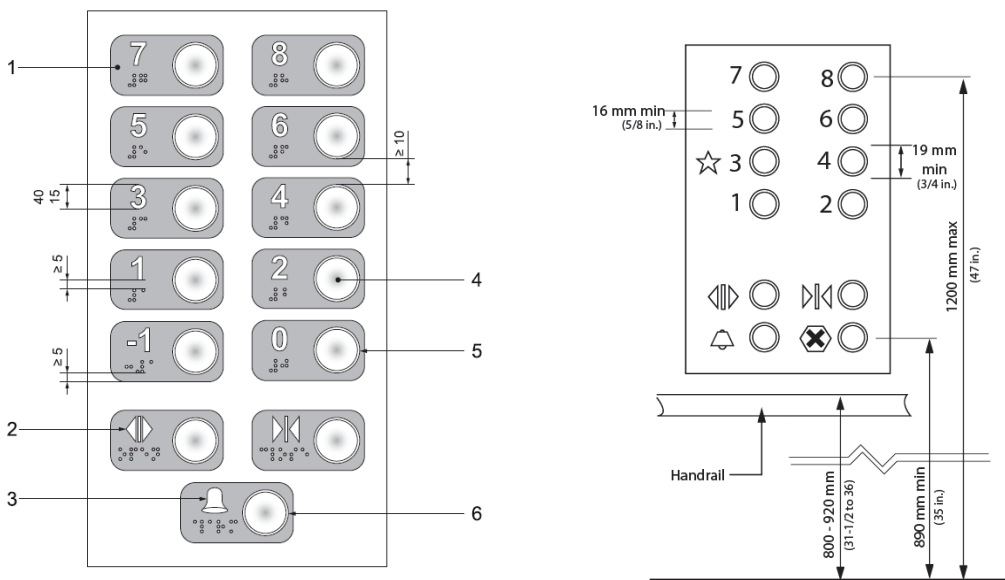

## Key

1. Visual contrast to the faceplate
2. Tactile symbols with visual contrast to the background
3. Alarm bell as tactile symbol in yellow colour
4. Round push button with visual contrast between the button and the background
5. Ring around the button that provides operating feedback (i.e. lights up when pushed)
6. Yellow ring around the button

**Figure 71: Examples of Vertical Arrangement of Round Push Buttons with Tactile Characters**

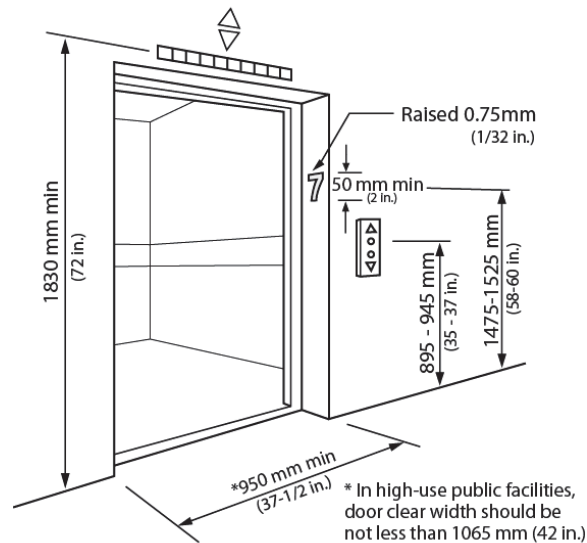

**Figure 72: Elevator Entry**

## Platform Lifts

Platform lifts should only be considered when installing ramps or elevators is not feasible, typically in retrofit scenarios. It is essential that platform lifts provide independent access without the need for assistance.

### Requirements

- Platform lifts must be located on an accessible route and comply with Section 3.3 Interior Paths of Travel
- Platform lifts must adhere to CSA B355 (latest edition), providing unassisted entry and exit. Tactile features and Braille signage must be provided
- Signage: Platform lifts must be clearly identified using signage that complies with Section 5.9 Signage and Wayfinding

- Lift Dimensions: Platform lifts should have a minimum size of 1100 mm by 1400 mm for manual and powered wheelchairs. Where space is constrained, smaller dimensions (e.g., 800 mm by 1250 mm) may be considered for vertical lifts
- Safety Features: Safety wheel guards must be included along all exposed edges of the platform
- Platform lifts must be linked to an emergency communication system and equipped with a two-way communication system
- Controls: Platform lift controls must be fully operable with tactile symbols, and the highest operable portion of any emergency communication system should be no more than 1200 mm from the platform floor

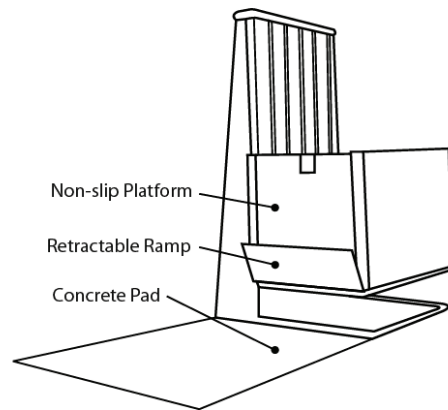

**Figure 73: Vertical Platform Lift**

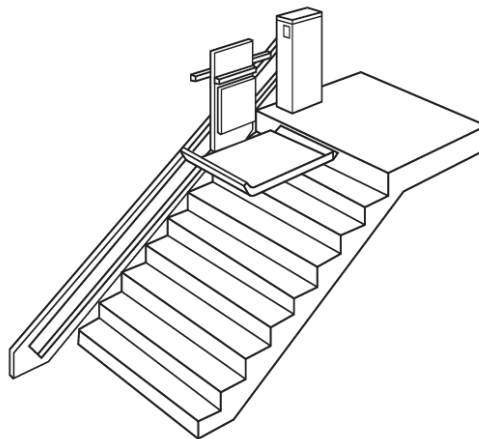

**Figure 74: Inclined Platform Stair-Lift**

# Escalators

## Rationale

Boarding and disembarking from an escalator can present challenges for individuals with limited agility or timing difficulties. Furthermore, the lack of contrast on the edges of steps may make it difficult for users, especially those with vision impairments, to see the position or assess the speed of the escalator.

To improve safety and accessibility, detectable warning surfaces should be placed in front of the escalator to alert pedestrians, particularly those with vision impairments. Additionally, contrasting colour strips should be placed on the edges of the steps to enhance visibility and aid in safe navigation.

## Application

This section applies to all escalators provided within a facility.

Where escalators are provided, an **alternate accessible route** must also be available nearby to provide access for individuals who are unable to use the escalator.

- In facilities where an escalator or inclined moving walkway offers access to floors above or below the entrance level, an interior barrier-free path of travel must also be provided to these floors
- The route from the escalator or inclined moving walkway to the barrier-free path must be clearly identified with appropriate signage
- In buildings with a moving walkway serving areas on the same floor level, a barrier-free path of travel must be available between the areas connected by the walkway

## Requirements

- Tread Edges and Nosing:
  - Escalator installations must include high-definition colour contrast on tread edges and nosings to improve visibility for all users
- Warning Surfaces:
  - Detectable warning surfaces in compliance with Section 2.8 Tactile Walking Surface Indicators must be installed at both the head and foot of the escalator to alert users of potential changes in elevation
- Tread Surface:
  - The surface of escalator treads must have a matte finish to minimize reflected glare, ensuring better visibility and reducing discomfort for those with visual impairments
- Lighting:
  - Lighting above escalators must provide a minimum of 200 lux (18.4 ft-candles) of evenly distributed, low-glare light to improve visibility and safety during use

## TSSA Compliance

- Escalators must comply with the requirements of the TSSA as outlined in the ASME A17.1/B44-2019 (Safety Code for Elevators and Escalators), which covers critical safety aspects like:
  - Emergency Communication Systems: Escalators should be equipped with a two-way communication system to connect users to emergency services in case of a malfunction or incident.
  - Emergency Stop Buttons: Escalators must be equipped with emergency stop buttons that can be easily activated by users in the event of an emergency

**Table 58: Elevating Devices – At a Glance**

| Feature                        | Minimum / Recommended Dimensions  | Notes / Key Requirements   |
|--------------------------------|---|--|
| <b>General Compliance</b>      | <ul style="list-style-type: none"> <li>• N/A</li> </ul>   | <ul style="list-style-type: none"> <li>• Must comply with OBC, CSA B44, CSA B355, CSA B651 and TSSA regulations</li> </ul>   |
| <b>Location &amp; Access</b>   | <ul style="list-style-type: none"> <li>• Manoeuvring space: 1500 × 1500 mm in front of entrances</li> <li>• Retrofit allowance: 1200 × 1200 mm (minimum)</li> </ul>   | <ul style="list-style-type: none"> <li>• Must be on an accessible route</li> <li>• Entrances should contrast with walls</li> <li>• Tactile/Braille floor designations at 1500 ± 25 mm AFF</li> </ul> |
| <b>Doors</b>                   | <ul style="list-style-type: none"> <li>• Clear opening: 950 mm minimum</li> <li>• Power-operated horizontally sliding</li> </ul>  | <ul style="list-style-type: none"> <li>• Automatic levelling ± 13 mm</li> </ul>  |
| <b>Elevator Car Dimensions</b> | <ul style="list-style-type: none"> <li>• Wheelchair-use: 950 mm door, 1100 mm width, 1400 mm length</li> <li>• Stretcher-use: 950 mm door, 1100 mm width, 2100 mm length</li> <li>• High use: 1065 mm door, 1725 mm width, 1525 mm length</li> <li>• Arenas/libraries: 1065 mm door, 2030 mm width, 1525 mm length</li> </ul> | <ul style="list-style-type: none"> <li>• See Table 7 for detailed specs</li> <li>• Retrofit minimum 1100 × 1370 mm</li> </ul>  |
| <b>Handrails</b>               | <ul style="list-style-type: none"> <li>• Mounted 800–950 mm AFF (preferred 850 ± 25 mm)</li> </ul>  | <ul style="list-style-type: none"> <li>• At least one handrail required in retrofit</li> <li>• 40–45 mm wall clearance</li> </ul>  |

| Feature                            | Minimum / Recommended Dimensions   | Notes / Key Requirements  |
|------------------------------------|--|---|
| <b>Foldable Seat (if provided)</b> | <ul style="list-style-type: none"> <li>• Height: 500–520 mm</li> <li>• Depth: 400–500 mm</li> <li>• Width: 500–600 mm</li> <li>• Load: 150 kg</li> </ul>   | <ul style="list-style-type: none"> <li>• Optional but must allow secure independent use</li> </ul>  |
| <b>Lighting</b>                    | <ul style="list-style-type: none"> <li>• 100 lux at floor</li> <li>• 200 lux at controls</li> </ul>  | <ul style="list-style-type: none"> <li>• Uniform, non-glare distribution</li> </ul>   |
| <b>Emergency Communication</b>     | <ul style="list-style-type: none"> <li>• Controls ≤1200 mm AFF</li> <li>• Symbols ≥38 mm high, raised 0.75 mm</li> <li>• Handset cord ≥735 mm</li> </ul>   | <ul style="list-style-type: none"> <li>• Two-way voice + visual + text; must comply with CSA T515</li> </ul>  |
| <b>Control Devices</b>             | <ul style="list-style-type: none"> <li>• Buttons: ≥19 mm, with Braille &amp; raised characters</li> <li>• Highest floor button ≤1200 mm AFF</li> <li>• Alarm/emergency stop ≥890 mm AFF</li> </ul> | <ul style="list-style-type: none"> <li>• Provide tactile + visual + audible feedback</li> <li>• Avoid touchscreen-only systems</li> </ul>   |
| <b>Platform Lifts</b>              | <ul style="list-style-type: none"> <li>• Preferred min: 1100 × 1400 mm</li> <li>• Retrofit: 800 × 1250 mm</li> </ul>   | <ul style="list-style-type: none"> <li>• CSA B355 compliant</li> <li>• Provide independent entry/exit; emergency communication required</li> </ul>  |
| <b>Escalators</b>                  | <ul style="list-style-type: none"> <li>• Detectable warning surfaces at head &amp; foot</li> <li>• Step edges with high contrast nosings</li> <li>• Lighting ≥200 lux</li> </ul>                   | <ul style="list-style-type: none"> <li>• Must have alternate accessible route</li> <li>• Comply with TSSA/ASME A17.1/B44</li> <li>• Provide emergency stop buttons and 2-way communication</li> </ul> |

## 3.7 Service Counters

### Rationale

Service counters are key points of interaction. To ensure equitable access, counters should provide:

- Multiple heights to accommodate users of varying stature, mobility, and seated positions
- Accessible writing surfaces and speaking ports
- Assistive listening technology for individuals who are deaf, hard of hearing, or have speech impairments
- Visual, tactile, and audio cues to assist users with vision impairments

### Application

This section applies to service counters used by the public and staff, including:

- Reception desks
- Information desks or kiosks
- Food service counters
- Check-out counters
- Teller counters
- Security counters

Where a single queuing line serves multiple counters, each counter must comply with this section.

### Requirements

#### General

- Located on an accessible route
- At least one accessible section per service type

#### Design and Layout

Furniture, fixtures and equipment at service counters should be usable by all individuals. Counters for information, reception or service must incorporate at least one accessible section that:

- Counter height: 730 mm - 865 mm above finished floor or ground

- Clear floor space:
  - Front approach: 900 mm wide x 1500 mm long minimum (Figure 73)
  - Side approach: 900 mm wide x 2200 mm long minimum
- Knee space: Minimum 685 mm high x 480 mm deep x 810 mm wide
- Speaking ports: at least one no higher than 1060 mm above the finished floor or ground
- Multiple queuing lines: accessible counters clearly identified by signage

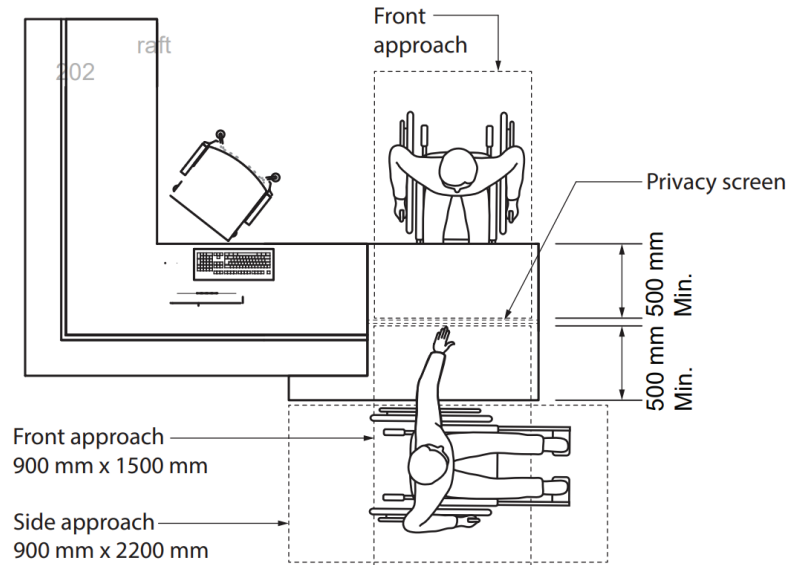

**Figure 75: Clear Floor Space**



**Figure 76: Knee and Toe Space**

## Signage and Visual Cues

- Clear identification of accessible counters
- Signage indicating type of accessibility device available (if one is) or how to request accommodation
- Surface contrast: minimum 70% colour/tonal contrast with adjacent surfaces
- Lighting: minimum 50 lux at floor level for visual communication, lipreading or other communication

## Communications and Information Systems

Where possible, provide:

- At least one type of assistive listening device at each counter
- Speech Transfer Intercom System with volume controls for staff and customers
  - This can be in a counter system or speaking port
- Adjustable microphones or telephones with voice/speech amplification
- Two-way communication systems (e.g., Ubi Duo) for persons who are deaf, deafened or hard of hearing

**Table 59: Service Counters at a Glance**

| <b>Feature</b>              | <b>Minimum / Recommended Dimensions</b>   | <b>Notes / Key Requirements</b>   |
|-----------------------------|---|---|
| <b>Counter Height</b>       | <ul style="list-style-type: none"> <li>• 730–865 mm above floor</li> </ul>                              | <ul style="list-style-type: none"> <li>• At least one accessible counter per service type</li> <li>• Multiple heights encouraged for universal use</li> </ul> |
| <b>Clear Floor Space</b>    | <ul style="list-style-type: none"> <li>• Front: 900 × 1500 mm</li> <li>• Side: 900 × 2200 mm</li> </ul> | <ul style="list-style-type: none"> <li>• Must allow both front and side approaches</li> <li>• Connect directly to accessible route</li> </ul>                 |
| <b>Knee Space</b>           | <ul style="list-style-type: none"> <li>• 685 mm high × 480 mm deep × 810 mm wide</li> </ul>             | <ul style="list-style-type: none"> <li>• Provide unobstructed space under counter for seated users</li> </ul>   |
| <b>Speaking Port Height</b> | <ul style="list-style-type: none"> <li>• ≤ 1060 mm above floor</li> </ul>                               | <ul style="list-style-type: none"> <li>• Include at least one accessible communication port</li> </ul>  |

| Feature  | Minimum / Recommended Dimensions  | Notes / Key Requirements  |
|--|---|---|
| <b>Approach &amp; Access</b>                       | <ul style="list-style-type: none"> <li>On accessible route</li> </ul>                       | <ul style="list-style-type: none"> <li>Counters should be recessed or designed to allow front and side access without obstruction</li> </ul>  |
| <b>Signage</b>                                     | <ul style="list-style-type: none"> <li>Mounted per Section 5.8</li> </ul>                   | <ul style="list-style-type: none"> <li>Clearly identify accessible counters</li> <li>Minimize visual clutter where assistive systems are integrated</li> </ul>  |
| <b>Surface Contrast</b>                            | <ul style="list-style-type: none"> <li><math>\geq 70\%</math> luminance contrast</li> </ul> | <ul style="list-style-type: none"> <li>Between counter surface and surroundings to aid visibility</li> </ul>  |
| <b>Lighting Level</b>                              | <ul style="list-style-type: none"> <li><math>\geq 150</math> lux at counter</li> </ul>      | <ul style="list-style-type: none"> <li>Provide even, glare-free lighting to support visual communication</li> </ul>   |
| <b>Assistive Listening / Communication Systems</b> | <ul style="list-style-type: none"> <li>Where possible</li> </ul>                            | <ul style="list-style-type: none"> <li>Provide at least one assistive listening device or equivalent technology per counter, such as adjustable microphones, amplified telephones, or two-way communication systems (e.g., UbiDuo)</li> </ul> |
| <b>Furniture &amp; Fixtures</b>                    | <ul style="list-style-type: none"> <li>N/A</li> </ul>                                       | <ul style="list-style-type: none"> <li>Must not obstruct accessible routes</li> <li>Moveable elements should maintain clear width and approach spaces</li> </ul>  |

## 3.8 Washrooms

### Section summary

This section outlines the accessible design requirements for:

- Multi-Stall Washrooms
- Ambulatory Water Closet Stalls and Enclosures
- Accessible Water Closet Stalls and Enclosures
- Single-Use Washrooms
- Universal Washrooms
- Grab Bars
- Lavatories
- Washroom Amenities
- Urinals

### Rationale

Accessible washrooms support independence, dignity and inclusion for all users – including individuals with disabilities, caregivers and families. These facilities must accommodate a wide range of physical, sensory and cognitive needs while ensuring safety, comfort and usability. Accessible washrooms must be designed for independent use, clear identification and equitable access for everyone.

### Application

This section applies to all washrooms in City facilities including but not limited to:

- Multi-stall washrooms
- Single-user washrooms
- Universal washrooms
- Change rooms with washroom features

These requirements also apply to new construction and major renovations where feasible. Portable washrooms are included when provided for public use.

Accessible washrooms must:

- Be located within 45m of public areas

- Be connected to accessible routes per Section 2.2 Interior Accessible Routes
- Be identified with clear, high-contrast signage compliant with Section 5.9 Signage and Wayfinding

## Design Requirements

### General Features

- Accessible washrooms must be located along an accessible path of travel
- Directional signage is required when washrooms are not immediately visible (see Section 5.9 Signage and Wayfinding)
- Provide a clear turning diameter of 1500 mm minimum (preferred 1700 mm)
- Floor surfaces must be slip-resistant with a maximum slope of 1:50 (2%)
- Public washrooms should open to accessible corridors to allow after-hours access where feasible

### Types of Washrooms

Washrooms should meet the needs of a diverse and growing population of people with disabilities. To meet this need, the City utilizes a variety of washroom types and designs:

- Multi-stall washrooms
  - Ambulatory water closet stalls
  - Accessible water closet stalls
- Universal washrooms
- Single-user washrooms
  - Both multi-stall and single occupancy

## Multi-stall washrooms

### Quantity Requirements

The minimum number of accessible water closets required per washroom is based on the total number of water closets provided. Refer to Table 1 for minimum requirements:

**Table 60: Minimum Number of Accessible Water Closets**

| Number of water closets per washroom | Minimum number of accessible water closets per washroom             |
|--------------------------------------|---|
| 1-3                                  | 0, (if a universal washroom is within 45 m) or 1 (if none provided) |
| 4-9                                  | 1   |
| 10-16                                | 2   |
| 17-20                                | 3   |
| 21-30                                | 4   |
| Over 30                              | 5 plus 1 per additional 10  |

**Note:** Additional accessible water closets should be considered in locations where a higher proportion of seniors, older adults or persons using mobility devices is anticipated such as health care facilities, seniors centres and recreation and community centres.

### Accessible Stalls - General Requirements

- At least one accessible stall per multi-stall washroom
- Maintain a minimum clearance of 1400 mm between the outside wall of the stall and any wall-mounted fixture or obstruction
- Provide clear floor space of 1500 mm by 1500 mm in front of the accessible stall
- Provide a clear transfer space of 900 by 1500 mm adjacent to the water closet, within the same stall, unobstructed by doors, fixtures or partitions
- Ensure lighting is evenly distributed with a minimum of 200 lux
- Provide clear signage indicating accessible features (e.g., Braille, tactile elements, International Symbol of Accessibility)

#### Stall Doors

- Provide a minimum clear width of 850 mm (900 mm preferred)
- Maintain 1700 mm clearance between the inside face of an in-swinging door and adjacent water closet wall
- Doors must swing outward unless 920 by 1500 mm clear floor space is available inside
- Doors must be self-closing with spring or gravity hinges

- Provide door hardware operable with one hand (e.g., lever or pull handle) and mounted 750-850 mm A.F.F.
- Operable with one hand, without tight grasping, pinching or twisting

Note: Wherever possible, consider the use of privacy walls or specialized configuration of entrance vestibules to avoid the need for doors and power door operators. Entrances without doors are easier for everyone to use. Where entrances are door-less, provide identification signage on both sides of the entrance openings.

## Water Closets

- Seat height: 430-485 mm A.F.F.
- Centreline from wall: 460-480 mm
- Transfer space: 900 mm wide by 1500 mm deep minimum (on at least one side)
- Flush controls: closed-fist operable and with a force not exceeding 22.2 N
- Install coat hook mounted at 1200 mm maximum A.F.F.

## Ambulatory Water Closet Stalls

- Stall width: 920-940 mm
- Stall depth: Minimum 1500 mm (Figure 54)
- Doors must swing outward and close automatically
- Equip with L-shaped grab bars on both sides of the water closet
- Provide a coat hook mounted at 1200 mm maximum height

## Grab Bars

- Must withstand 1.3kN in all directions
- Grasping surface: 30-40 mm diameter
- Horizontal bar:
  - 840-920 mm A.F.F, mounted behind water closet
  - Ensure length of 600 mm (minimum)
- L-shaped bar:
  - Mount vertical component 150 mm from front of water closet, horizontal component 850 mm A.F.F.
  - Ensure length of 760 mm (minimum) for both vertical and horizontal components
- Fold down grab bars:
  - Mount on the wall behind the water closet

- Locate on transfer space side(s) (e.g., both sides where a clear transfer space is provided on each side of the water closet)
- Ensure length of 760 mm (minimum)
- Mount with centerline between 390 mm and 410 mm from centerline of water closet
- Mount with the horizontal component at 750 mm high from floor level
- Ensure force required to pull down grab bar is no more than 22 Newtons

## Lavatories

- At least one accessible lavatory in each washroom
- Top of lavatory: 820-850 mm A.F.F.
- Clear space beneath lavatory: 735 mm high by 920 mm wide
- Toe clearance 350 mm deep minimum
- Faucet controls: lever or automatic, operable with a closed fist
- Ensure faucet controls, soap dispensers, hand dryers or paper towel dispensers within reach range (see Section 2.1)
- Ensure all fixtures have colour/tonal contrast from the surrounding environment
- Ensure water pipes are covered or insulated below lavatories

## Urinals

- At least one accessible urinal per washroom
- Rim height: maximum 430 mm (or floor-mounted unit)
- Install grab bars on both sides of urinal
- Centreline indicator with high colour contrast
- Provide clear floor space that:
  - Is 810 mm by 1370 mm for a front approach
  - Is located perpendicular to, and centred on, the urinal and unobstructed by privacy screens
  - Has no step in front of it
- Where privacy screens are provided
  - Provide clearance of 920 mm (minimum) between screens
  - Ensure a clearance of 50 mm (minimum) from the grab bars
  - Ensure colour contrast between screens and surrounding surfaces
  - Ensure the vertical outer edge provides a high colour contrast

Where a washroom contains more than two urinals, one urinal shall be provided specifically for children that is:

- Installed with the rim no higher than 430 mm from the finished floor OR floor-mounted, with the rim level at the finished floor

### **Accessible Water Closet Stalls**

- Install a sign with the International Symbol of Accessibility
- Provide a clear turning space of 1500 mm diameter minimum
- Mount a coat hook at 1200 mm maximum height, on a side wall and projecting 50 mm maximum from mounting surface

### **Single-Use Washrooms**

Single-use washrooms, also known as single-occupancy or individual washrooms, are restrooms designed for use by one person. Single-use washrooms are often labeled “gender-neutral” or “all-gender,” making them inclusive spaces for individuals regardless of identity.

There are three types of single-use washrooms:

#### 1. Multi-stall washrooms

Multi-stall washrooms are designed to be gender-inclusive. Features include:

- Floor-to-ceiling enclosures for water closets, creating individual water closets as opposed to stalls with partial dividers
- Shared sinks and mirrors outside of the stalls
- Marked as gender-neutral with appropriate signage

#### 2. Single-use washrooms

Private, single-occupancy facilities that anyone can use, regardless of gender. Features include

- Water closet and lavatory
- Lockable door
- Marked as gender-neutral with appropriate signage

#### 3. Universal washrooms

Large, fully enclosed washrooms that anyone can use, regardless of gender but are designed to accommodate people with disabilities and others who may need additional space or assistance. Features include (but are not limited to):

- Barrier-free water closet and sink
- Turning space to accommodate a wheeled mobility device
- Automatic doors

- Emergency response systems
- Space for an adult-sized change table

### **Quantity**

- At least one single-use washroom must be provided in all public buildings
- The quantity of single-use washrooms should consider the use and occupancy of a facility and the needs of all individuals on every floor, level or storey, as well as throughout the facility

Universal washrooms are considered single-use washrooms and will be utilized to meet any single-use washroom strategy for a facility.

Note: while every universal washroom is considered a single-use washroom, not every single-use washroom meets the criteria of a universal washroom.

### **Location**

Single-use washrooms should be:

- Located in the same vicinity as other washrooms (e.g., men's and women's multi-stall washrooms, universal washrooms, etc.)
- Distributed throughout a building as appropriate to the building design and operation
- Located in publicly accessed areas so that individuals are provided with independent, equitable and dignified access to single-use washrooms

## **Technical requirements**

### **Single-Use Washrooms**

- In multi-stall single-use washrooms, provide floor-to-ceiling partitions and doors each stall, with separate lighting, sprinklers and exhaust systems
- Provide clear turning circle of 1500 mm minimum
- Signage to indicate gender-neutral use and accessibility and meet the requirements of Section 5.9 Signage and Wayfinding
- Include toilet with floor-to-ceiling partitions and lockable door
- Door hardware operable with closed fist

### **Universal Washrooms**

Universal washrooms benefit people with attendants of opposite gender, families and people who prefer alternatives to multi-stall washrooms.

#### **Location and Quantity**

- Must be located within 45 m from other washrooms

- The Minimum number of universal washrooms per building should meet the following criteria:

**Table 61: Minimum Number of Universal Washrooms**

| <b>Number of storeys in Building</b> | <b>Minimum number of Universal Washrooms per Building</b>                   |
|--------------------------------------|---|
| 1 to 3                               | 1   |
| 4 to 6                               | 2   |
| Over 6                               | 3 plus 1 for each additional increment of 3 storeys in excess of 6 storeys. |

#### **Clear floor space**

- Minimum 2500 mm turning circle, clear of obstruction
  - In a retrofit situation where providing the required turning space is technically infeasible, the turning space may be reduced to 2130 mm with priority given to allow enough clear space between the toilet and the lavatory
- Minimum 900 mm x 1500 mm clear transfer space on one side of the water closet

#### **Doors**

- Equipped with a power operator that coordinates with an automatic locking system
- Is operable using a closed fist and with a force of 22N maximum
- Is located between 900 mm to 1000 mm A.F.F.
- Has a power locking mechanism that can be locked from the inside and released from the outside, in case of emergency
- Has related signage indicating the door locking/unlocking procedures, installed next to the locking/unlocking controls:
  - Sign on the inside that is illuminated with the word “LOCKED” when the door is locked
  - Sign on the outside that is illuminated with the words “IN USE” when the door is locked

#### **Fixtures**

- Provide one accessible lavatory with other washroom amenities including but not limited to mirror, soap dispenser, paper towel dispenser, automatic hand dryer (preferred), coat hook, and toilet paper dispenser as identified in this section
- Provide motion sensor for automatic illumination of interior
- Install audible and visual fire alarm systems
- Meet the requirements in this section related to:
  - Grab bars

- Accessible water closets
- Lavatories
- Ensure drains are installed out of the path of travel

**Park washrooms:** Where there is no connection to a central monitoring location, localized visual and audible alarms shall be provided.

#### **Adult Change Table**

- Provide space for adult-sized change table (810 mm wide by 1830 mm long minimum) in each universal washroom (Figure 67)
- Provide a reinforced wall to permit the future installation of the change table and carry a load of 1.33kN
- Where installed:
  - Have an adjustable surface height range from 450 mm A.F.F. to 900 mm A.F.F.
  - Be wall mounted and is a fold-down table that does not encroach into a clear floor space
  - Have operable portions or controls that are not higher than 1100 mm
  - Have an electrical power source for plug-in hydraulic power assisted models

**Exception:** Where another universal washroom with an adult-sized change table is provided on the same floor level within 45m.

**Exception:** A fixed adult change table may be installed in a park washroom building.

#### **Emergency Call System**

- Must consist of visual and audible signal devices both inside and outside of the washroom that are activated by a push control device inside the washroom
- Provide an emergency sign that:
  - Is posted above the operable portions or controls of the emergency button
  - Contains the words “IN THE EVENT OF AN EMERGENCY PUSH EMERGENCY BUTTON AND AUDIBLE AND VISUAL SIGNAL WILL ACTIVATE” in letters at least 25 mm high with a 5 mm stroke and that is posted above the emergency button
- Must be linked to a centrally monitored switchboard for facilities that have the capacity

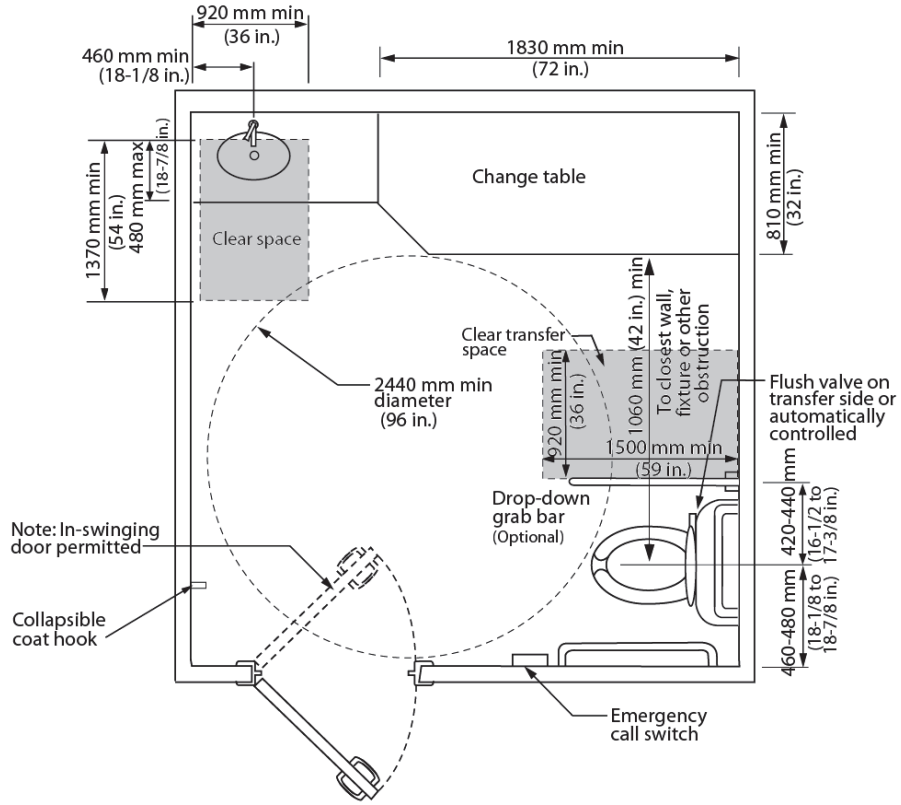

**Figure 77: Universal Washroom**

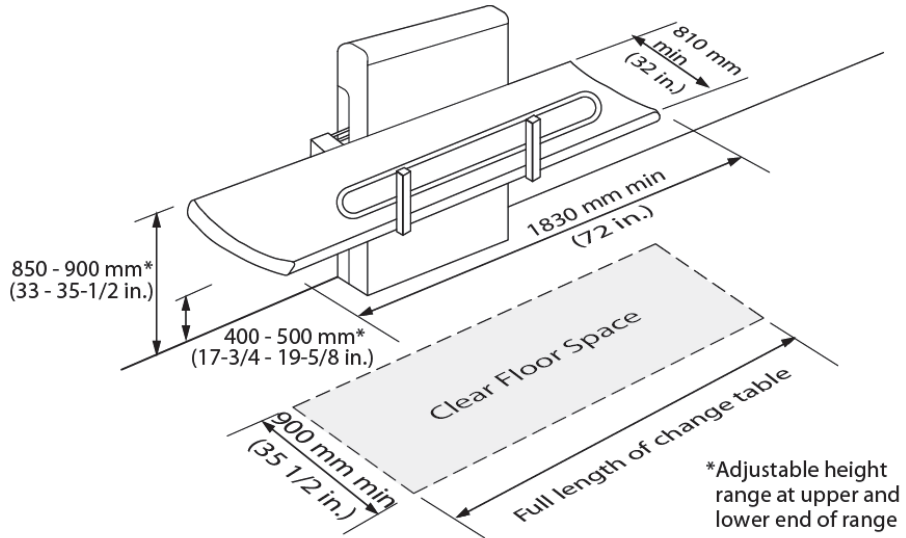

**Figure 78: Adult Change Table**

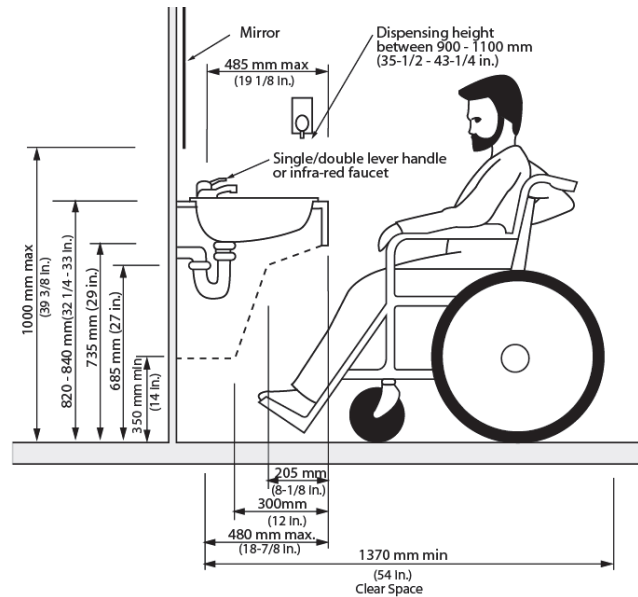

**Figure 79: Lavatory Criteria**

## Shelves

When providing shelves, ensure that it:

- Is mounted 1200 mm maximum A.F.F. and locate in a manner it will not create an obstruction
- Is located not more than 200 mm above the surface of the lavatory
- Projects no more than 100 mm from the wall

## Washroom Amenities

Washroom amenities include, but are not limited to, hand dryers, paper towel dispensers, soap dispensers, waste bins, mirrors and changing stations and tables.

Where provided

- Wall-mounted amenities must not project more than 100 mm from the wall along an accessible path of travel
- Provide colour-contrasted finishes between amenities and mounting surfaces to improve visibility
- Operating controls and dispensing mechanisms must be:
  - Mounted 900-1100 mm above the finished floor
  - Automatic, push button or operable with one hand without tight grasping, pinching or twisting of the wrist
  - Operable with less than 22 Newtons (5 pounds) of force
- Provide minimum clear floor space of

- 915 mm wide by 1370 mm for a front approach
- 1525 mm wide by 915 mm for a side approach

## Mirrors

- Mount above lavatories with the bottom edge no higher than 1000 mm above the finished floor, or angle mirrors to the vertical so they are usable from both seated and standing positions
- Where full-length mirrors are provided, ensure they are not located where reflections could overlap with the path of travel or create confusion for users

## Signage

- Install Braille and tactile signage with International Symbol of Accessibility at all accessible washrooms
- Mount signage 1370–1525 mm AFF to centreline
- High contrast letters 13–19 mm high
- Directional signs provided where washrooms are not visible

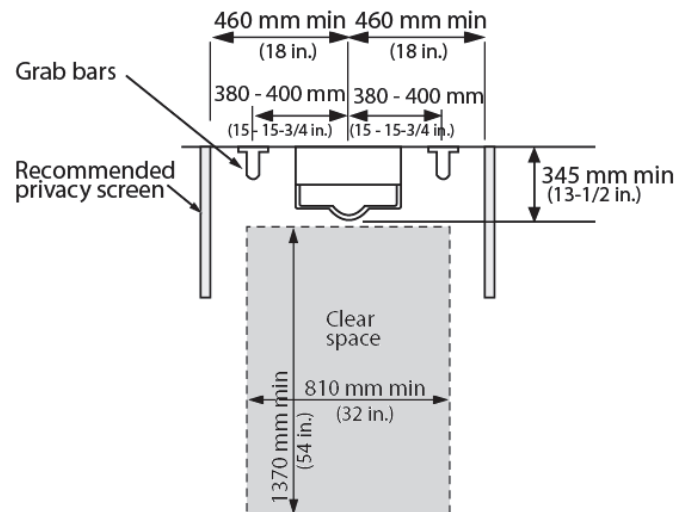

**Figure 80: Urinal top view**

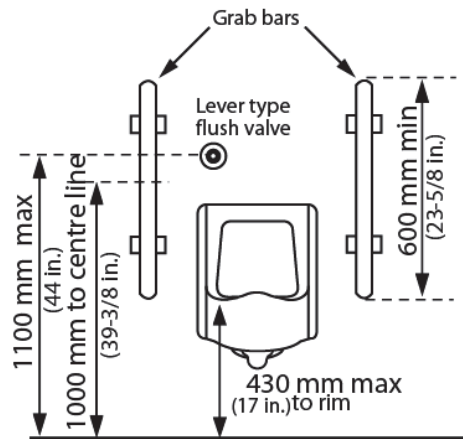

Figure 81: Urinal front view

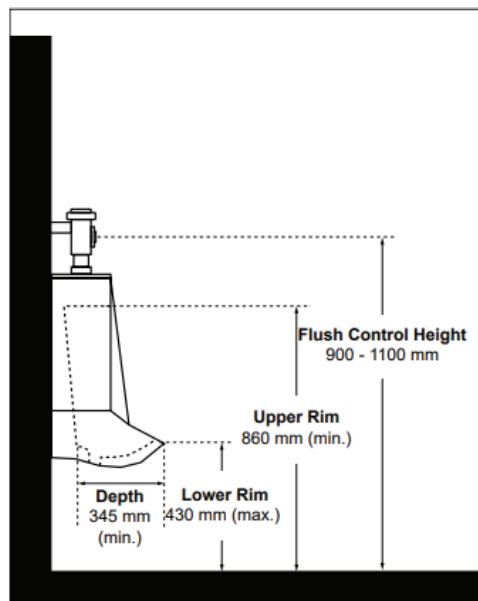

Figure 82: Urinal – Side Elevation

## Technical Notes

- Measurements are to be taken to the **finished surfaces** unless otherwise noted.
- All clear floor spaces are **unobstructed** by doors, fixtures, or other elements.
- Turning spaces may **overlap** with clear floor spaces or accessible routes.
- Where existing site constraints make full compliance technically infeasible, **equivalent facilitation** must be demonstrated through an accessibility review.
- **Slip-resistant flooring** must have a minimum static coefficient of friction of 0.8 (wet and dry).

- **Power door operators** for universal washrooms must meet CAN/CSA B651 and OBC 3.8.3.3 requirements for activation force, timing, and door control signage.
- **Grab bars** shall be designed and installed to withstand a load of **1.3 kN** applied in any direction.
- All **emergency call systems** must provide both **audible and visual** alerts and connect to a monitored location or local alarm as applicable.
- **Lighting** levels must achieve **200 lux minimum** in all washroom areas, with glare minimized through diffused or indirect fixtures.
- **Finishes** must provide minimum **70 % colour contrast** between fixtures and surrounding surfaces for improved visibility.

## Cross-References

This section should be read in conjunction with:

- **Section 2.2 – Ground and Floor Surfaces** – slip resistance, drainage, and thresholds
- **Section 2.4 – Stairs and Tactile Warnings** – applicable where stairs are adjacent to washrooms
- **Section 2.5 – Handrails** – grab bar design and mounting principles
- **Section 2.1 – Space and Reach Requirements** – reach ranges and clear floor areas
- **Section 3.2 – Entrances and Doors** – power-assisted and manual door operation
- **Section 3.3 – Interior Accessible Routes** – path connections to washrooms
- **Section 4.1 – Parking and Loading Zones** – proximity of accessible parking to entrances
- **Section 5.8 – Lighting** – illumination levels and fixture types
- **Section 5.9 – Signage and Wayfinding** – identification, tactile, and Braille signage requirements

**Table 62: Washrooms At a Glance**

| Feature                         | Minimum / Recommended Dimensions   | Notes / Key Requirements   |
|---------------------------------|--|--|
| Turning Space                   | <ul style="list-style-type: none"> <li>• 1500 mm diameter (min)</li> <li>• 1700 mm diameter (preferred)</li> </ul> | <ul style="list-style-type: none"> <li>• Clear of obstructions</li> </ul>                |
| Accessible Stall Transfer Space | <ul style="list-style-type: none"> <li>• 900 × 1500 mm</li> </ul>  | <ul style="list-style-type: none"> <li>• Within stall</li> <li>• Unobstructed</li> </ul> |

| Feature                                 | Minimum / Recommended Dimensions   | Notes / Key Requirements  |
|---|--|---|
| <b>Accessible Stall Clearance</b>       | <ul style="list-style-type: none"> <li>• 1400 mm between stall wall and fixtures</li> </ul>            | <ul style="list-style-type: none"> <li>• For manoeuvring</li> </ul>   |
| <b>Stall Door Width</b>                 | <ul style="list-style-type: none"> <li>• <math>\geq 850</math> mm (900 mm preferred)</li> </ul>        | <ul style="list-style-type: none"> <li>• Swing out unless <math>920 \times 1500</math> mm space inside</li> </ul>               |
| <b>Water Closet Seat Height</b>         | <ul style="list-style-type: none"> <li>• 430 – 485 mm AFF</li> </ul>                                   | <ul style="list-style-type: none"> <li>• Centreline 460 – 480 mm from wall</li> </ul>   |
| <b>Ambulatory Stall</b>                 | <ul style="list-style-type: none"> <li>• 920 – 940 mm wide <math>\times</math> 1500 mm deep</li> </ul> | <ul style="list-style-type: none"> <li>• L-shaped grab bars both sides</li> </ul>   |
| <b>Grab Bars</b>                        | <ul style="list-style-type: none"> <li>• 30 – 40 mm diameter</li> <li>• 840 – 920 mm AFF</li> </ul>    | <ul style="list-style-type: none"> <li>• Withstand 1.3 kN load</li> </ul>   |
| <b>Lavatory Height</b>                  | <ul style="list-style-type: none"> <li>• 820 – 850 mm AFF</li> </ul>                                   | <ul style="list-style-type: none"> <li>• 735 mm high clearance underneath</li> </ul>  |
| <b>Urinal Rim Height</b>                | <ul style="list-style-type: none"> <li>• <math>\leq 430</math> mm AFF</li> </ul>                       | <ul style="list-style-type: none"> <li>• Grab bars both sides</li> <li>• <math>810 \times 1370</math> mm clear space</li> </ul> |
| <b>Universal Washroom Turning Space</b> | <ul style="list-style-type: none"> <li>• 2500 mm diameter (clear) (2130 mm retrofit min)</li> </ul>    | <ul style="list-style-type: none"> <li>• May overlap with route</li> </ul>  |
| <b>Universal Washroom Door</b>          | <ul style="list-style-type: none"> <li>• Power-operated with 22 N max force</li> </ul>                 | <ul style="list-style-type: none"> <li>• Lock releasable from outside in emergency</li> </ul>                                   |
| <b>Adult Change Table Space</b>         | <ul style="list-style-type: none"> <li>• <math>810 \times 1830</math> mm (min)</li> </ul>              | <ul style="list-style-type: none"> <li>• Adjustable 450 – 900 mm AFF</li> <li>• Fold-down preferred</li> </ul>                  |
| <b>Emergency Call System</b>            | <ul style="list-style-type: none"> <li>• Visual + audible signals</li> </ul>                           | <ul style="list-style-type: none"> <li>• Linked to monitored station or local alarm</li> </ul>                                  |
| <b>Amenities Controls</b>               | <ul style="list-style-type: none"> <li>• 900 – 1100 mm AFF</li> </ul>                                  | <ul style="list-style-type: none"> <li>• Automatic or push-button</li> <li>• <math>\leq 22</math> N force</li> </ul>            |

| Feature                 | Minimum / Recommended Dimensions  | Notes / Key Requirements   |
|-------------------------|---|--|
| <b>Mirror Height</b>    | <ul style="list-style-type: none"> <li>• Bottom edge <math>\leq</math> 1000 mm AFF</li> </ul> | <ul style="list-style-type: none"> <li>• Usable from seated and standing positions</li> </ul>          |
| <b>Lighting Level</b>   | <ul style="list-style-type: none"> <li>• <math>\geq</math> 200 lux uniform</li> </ul>         | <ul style="list-style-type: none"> <li>• Diffused and glare-free</li> </ul>                            |
| <b>Signage Mounting</b> | <ul style="list-style-type: none"> <li>• 1370 – 1525 mm AFF to centreline</li> </ul>          | <ul style="list-style-type: none"> <li>• Braille, tactile, high-contrast letters 13 – 19 mm</li> </ul> |

## 3.9 Showers

### Rationale

Accessible showers remove barriers for individuals with disabilities and anyone who may have difficulty stepping over thresholds. Roll-in or curb-less shower stalls provide safe, easy access for people using wheelchairs or other mobility devices.

Safety features such as grab bars, non-slip flooring, and colour-contrasting fixtures support all users. Optional features such as hand-held shower heads, foldable or fixed shower seats, and recessed soap holders improve comfort, usability, and independence.

### Application

- At least one accessible shower is required where showers are provided
- In facilities with more than seven showers, additional accessible showers must be provided based on facility size (see Table 4.2.9)
- If two or more shower stalls are provided, at least one should be left-handed and at least one right-handed

**Table 63: Required Number of Showers**

| Number of Showers | Required Number Accessible           |
|-------------------|--------------------------------------|
| 1 – 7             | 1                                    |
| Over 7            | 2 + 1 for every 7 additional showers |

### Requirements

#### General Requirements

- Accessible showers must be on an accessible route (Section 3.3 Interior Accessible Routes)
- Minimum dimensions: 1525 mm wide × 920 mm deep
- Entrance clear floor space: Minimum 920 mm depth, same width as shower (fixtures may project if access not restricted)
- Flooring:

- Slip-resistant
- Shower recess gradient: 1 in 50 (2%) – 1 in 60 (1.67%) toward drain
- Area outside shower: 1 in 70 (1.43%) – 1 in 80 (1.25%) toward shower
- Threshold:
  - None, or bevel 13 mm maximum
- Water containment:
  - Trench-style drain with colour contrast, or equivalent measures

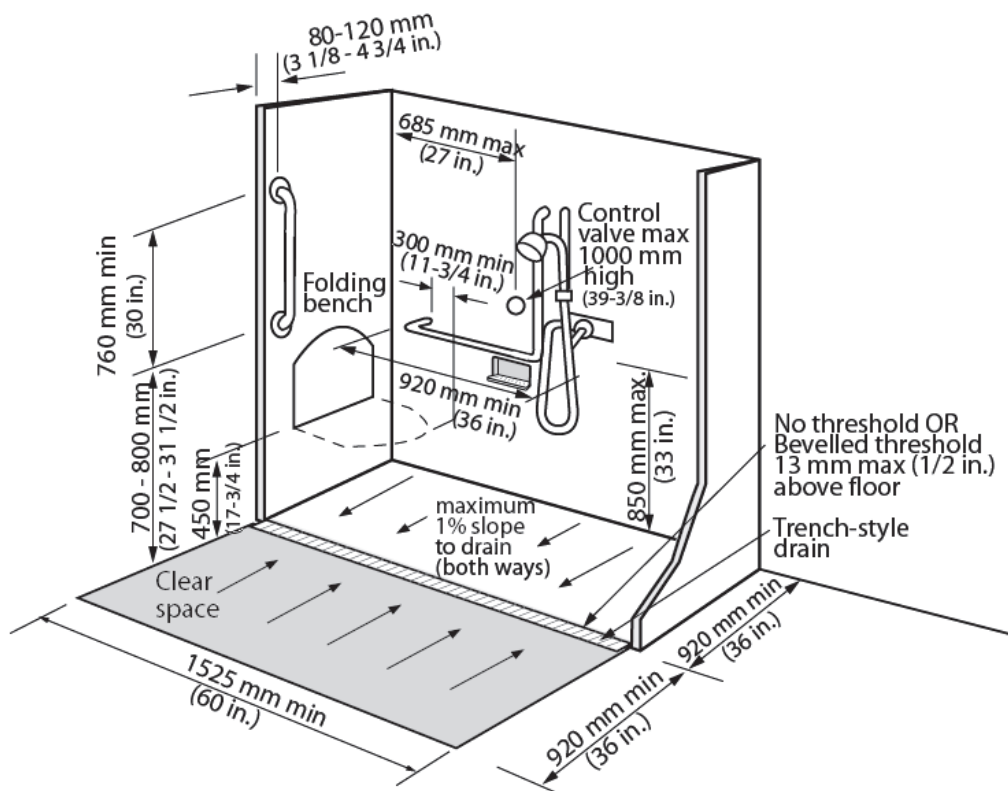

**Figure 83: Shower Stall**

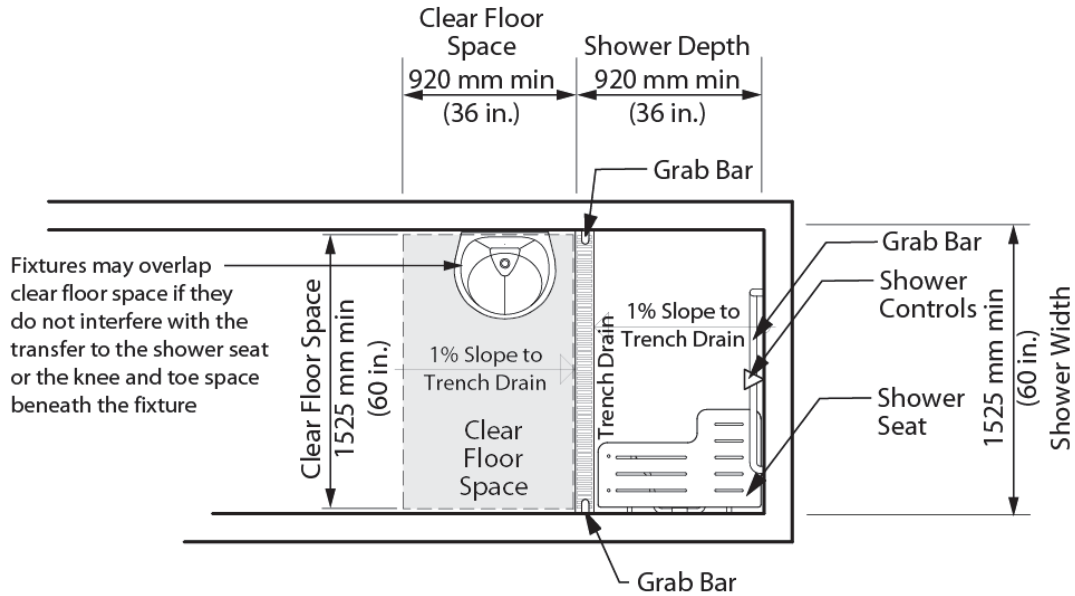

**Figure 84: Plan View of Accessible Shower**

## Seats

- Types: folding wall-mounted or fixed water-resistant seat
- Fixed seat dimensions:
  - Minimum width of 450 mm, minimum depth of 400 mm
  - Height 430 – 485 mm
  - Minimum load capacity of 1.33 kN (300 lbs)
  - Located no more than 500 mm from shower controls
- Folding seat features:
  - Folds upwards, self-draining, slip-resistant
  - Rounded corners: radius 10–15 mm, top edges 2–3 mm
  - Top surface 400–480 mm above floor, not more than 40 mm from wall
  - Fastenings withstand 1.1 kN in any direction
  - Preferably height-adjustable

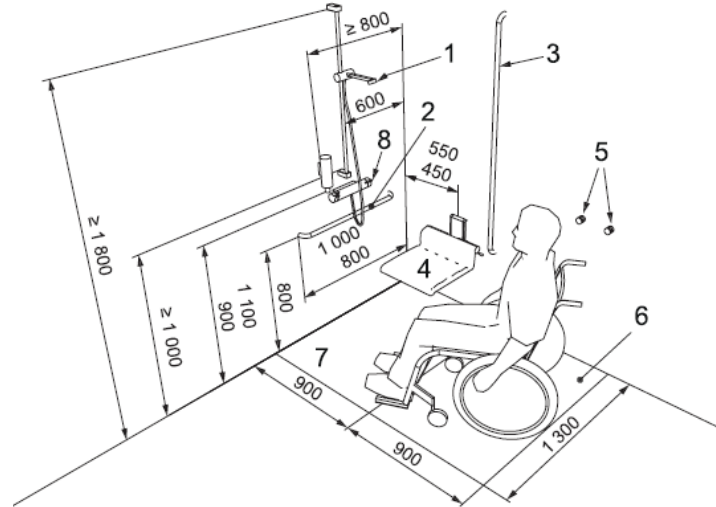

### Key

1. Hand-held shower head, adjustable in height
2. Horizontal grab rail
3. Vertical grab rail
4. Foldable shower seat with a height of the sitting surface between 400 mm and 480 mm
5. Towel hooks
6. Transfer area
7. Wet showering area with gradient 1 in 50 to 1 in 60
8. Shower controls

**Figure 85: Example of an Accessible Shower**

### Grab Bars

- L-shaped grab bar:
  - Between shower head and controls
  - Horizontal: 850 mm above floor, minimum 920 mm long
  - Vertical: minimum 760 mm long, overlaps seat at least 300 mm
- Vertical grab bars:
  - On each end wall, 760 mm long minimum
  - 80–120 mm from front edge
  - Mount height: 700–800 mm above floor

### Shower Controls

- Controls must be operable with one hand without tight grasping, pinching, or twisting of the wrist

- Maximum operating force: 22 Newtons for user controls, including manual pull stations and typical pushbuttons
- Push-button surfaces must be:
  - Minimum 13 mm diameter and not recessed for general controls
- Valve: thermostatic or pressure-equalizing, maximum 1000 mm above floor
- Controls for other devices (soap, taps): 900–1100 mm above floor
- Shower head:
  - Hand-held and fixed options
  - Hose 1525 mm minimum
  - Reachable from seated position
  - On/off control accessible from seat
- Alternative (vandalism-prone areas):
  - Two fixed-height shower heads (lower 1400 mm, upper 1825 mm)
  - Valve to direct water between heads

## Enclosures

- Shower curtains or doors must not obstruct circulation, controls, or transfers

## Combined Shower & Toilet

- Maneuvering areas may overlap (Figure 70)

## Individual Shower Rooms

- Clear space: minimum of 1300 × 900 mm on clear side of foldable seat
- Existing buildings exception: minimum of 1200 × 800 mm if constrained

## Additional Features

- Fully recessed niche reachable from seat
- Screening (curtain or door) must maintain entry space
- Shower wheelchairs may replace foldable seats

**Table 64: Shower Furniture - at a Glance**

| Element     | Requirement / Recommendation   | Notes / Application  |
|-------------|--|--|
| Shower Type | <ul style="list-style-type: none"> <li>• Roll-in or curb-less</li> </ul> | <ul style="list-style-type: none"> <li>• Eliminates threshold hazards</li> </ul> |

| Element                              | Requirement / Recommendation  | Notes / Application   |
|--------------------------------------|---|---|
|                                      |   | <ul style="list-style-type: none"> <li>• Essential for mobility device users</li> </ul>   |
| <b>Shower Width</b>                  | <ul style="list-style-type: none"> <li>• 1525 mm</li> </ul>   | <ul style="list-style-type: none"> <li>• Minimum clear width</li> </ul>   |
| <b>Shower Depth</b>                  | <ul style="list-style-type: none"> <li>• 920 mm</li> </ul>  | <ul style="list-style-type: none"> <li>• Minimum clear depth</li> </ul>   |
| <b>Clear Floor Space at Entrance</b> | <ul style="list-style-type: none"> <li>• Same width as shower, depth 920 mm</li> </ul>                      | <ul style="list-style-type: none"> <li>• Fixtures may project if access not restricted</li> </ul>   |
| <b>Threshold</b>                     | <ul style="list-style-type: none"> <li>• None or bevelled <math>\leq 13</math> mm</li> </ul>                | <ul style="list-style-type: none"> <li>• Prevents tripping, supports wheelchair entry</li> </ul>  |
| <b>Floor Slope (Shower)</b>          | <ul style="list-style-type: none"> <li>• 1:50 – 1:60</li> </ul>   | <ul style="list-style-type: none"> <li>• Drains water towards trench or floor drain</li> </ul>  |
| <b>Floor Slope (Outside)</b>         | <ul style="list-style-type: none"> <li>• 1:70 – 1:80</li> </ul>   | <ul style="list-style-type: none"> <li>• Drains towards shower recess</li> </ul>  |
| <b>Foldable Seat Dimensions</b>      | <ul style="list-style-type: none"> <li>• Width 450 mm, Depth 400 mm</li> </ul>                              | <ul style="list-style-type: none"> <li>• Mounted 430–485 mm above floor, stable, slip-resistant, water-resistant</li> </ul>                   |
| <b>Seat Load Capacity</b>            | <ul style="list-style-type: none"> <li>• <math>\geq 300</math> lbs (1.33 kN)</li> </ul>                     | <ul style="list-style-type: none"> <li>• Ensures safety for all users</li> </ul>  |
| <b>Grab Bars – Horizontal</b>        | <ul style="list-style-type: none"> <li>• <math>\geq 920</math> mm</li> </ul>                                | <ul style="list-style-type: none"> <li>• Overlaps seat by 300 mm, mounted 850 mm above floor</li> </ul>                                       |
| <b>Grab Bars – Vertical</b>          | <ul style="list-style-type: none"> <li>• <math>\geq 760</math> mm</li> </ul>                                | <ul style="list-style-type: none"> <li>• Mounted 80–120 mm from front edge, conforms to horizontal bar placement</li> </ul>                   |
| <b>Showerhead</b>                    | <ul style="list-style-type: none"> <li>• Hand-held or adjustable, hose <math>\geq 1525</math> mm</li> </ul> | <ul style="list-style-type: none"> <li>• On/off control reachable from seated position</li> </ul>   |
| <b>Shower Controls</b>               | <ul style="list-style-type: none"> <li>• Pressure-equalizing or thermostatic valve</li> </ul>               | <ul style="list-style-type: none"> <li>• Located within reach from seated position, above grab bar, <math>\leq 1000</math> mm high</li> </ul> |

| <b>Element</b>                          | <b>Requirement / Recommendation</b>   | <b>Notes / Application</b>  |
|---|---|---|
| <b>Accessories</b>                      | <ul style="list-style-type: none"> <li>• Soap holders, towel hooks, taps</li> </ul>       | <ul style="list-style-type: none"> <li>• Fully recessed or reachable from seated position</li> </ul>  |
| <b>Enclosures</b>                       | <ul style="list-style-type: none"> <li>• Curtain or door system</li> </ul>                | <ul style="list-style-type: none"> <li>• Must not obstruct controls, circulation, or manoeuvring</li> </ul>                                     |
| <b>Individual Shower Room Clearance</b> | <ul style="list-style-type: none"> <li>• Clear side of seat 1300 × 900 mm</li> </ul>      | <ul style="list-style-type: none"> <li>• Maneuvering space 1500 × 1500 mm</li> <li>• Exceptions for existing buildings 1200 × 800 mm</li> </ul> |
| <b>Colour Contrast</b>                  | <ul style="list-style-type: none"> <li>• Grab bars, seat, drain, showerhead</li> </ul>    | <ul style="list-style-type: none"> <li>• Supports users with low or no vision</li> </ul>  |
| <b>Safety / Slip Resistance</b>         | <ul style="list-style-type: none"> <li>• Non-slip flooring, self-draining seat</li> </ul> | <ul style="list-style-type: none"> <li>• Optional mats</li> <li>• Ensures safety for all users</li> </ul>                                       |

## 3.10 Change Rooms

### Rationale

Accessible and universal change rooms ensure equitable access to facilities. Universal change rooms allow for a person to be assisted by an attendant of the opposite sex or a parent assisting a child. Accessible change rooms provide space and elements for individuals with mobility devices. Multiple-occupancy change rooms accommodate larger groups while providing accessible elements. Handrails along circulation routes from change rooms to pool, gymnasium, or activity areas benefit all users

### Application

This section applies to change rooms, which may also be referred to as dressing / locker rooms or fitting areas, used by the public or employees. These spaces share common elements and design features. Typically, change rooms are provided in arenas, pools, fitness centres and related recreation and community centres.

### Requirements

#### Location and Quantity

- Provide at least one universal change room wherever team or gender-specific change rooms are available
- In multiple-occupancy change rooms with individual changing stalls, ensure at least 10% of stalls, but never fewer than one, are accessible
- Position universal change rooms and accessible changing stalls centrally within the facility, along an accessible route
- Where change rooms are not accessible, provide directional signage to guide users to the nearest accessible change room on the same floor
- Accessible change rooms must display the international symbol of accessibility

#### Universal Change Rooms

Universal change rooms are accessible, gender-neutral, single-use spaces that accommodate for privacy and assistance from persons of the opposite gender.

- Provide at least one universal change room wherever team or gender-specific change rooms exist
- Locate centrally along an accessible route

- Ensure clear turning circle between 1700 mm (minimum) to 2500 mm (preferred) to allow a person using a wheelchair or mobility device to make a 180-degree turn
- Provide an entrance door with a clear width of 860 mm minimum when door is in an open position and equip with power door operators
- Provide slip-resistant flooring with adequate drainage
- Install a full-length mirror at 460 mm wide by 1370 mm high, visible from bench and standing
- Ensure bench, grab bars, and accessories comply with the Amenities section
- Where showers or washrooms are part of the universal change room, apply accessibility requirements from Sections 3.7 Washrooms and 3.8 Showers
- Provide lighting in accordance with Section 5.8 Lighting

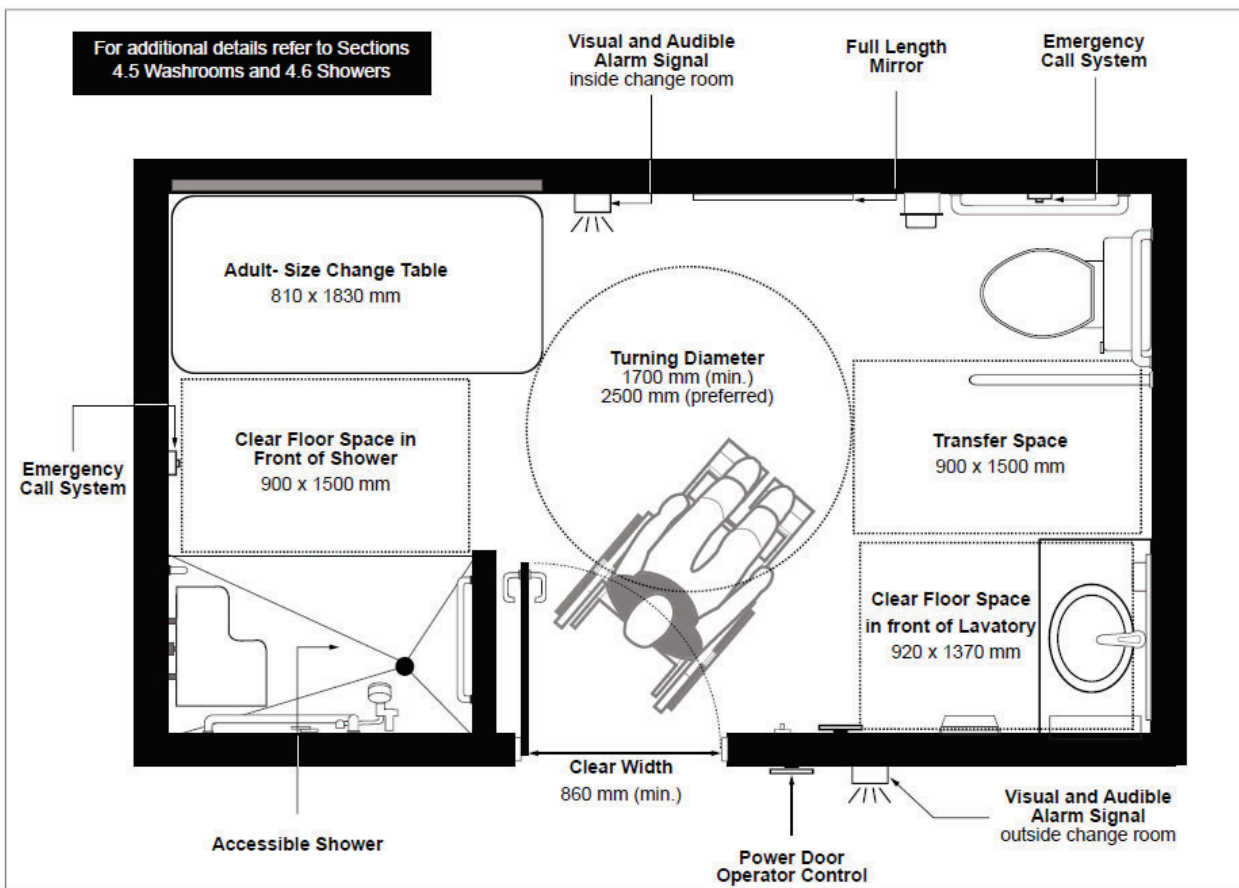

Figure 86: Universal Change Room

## Accessible Change Rooms / Private Accessible Change Rooms

- Provide at least one private accessible change room in each cluster of change rooms at pools, gymnasiums, and other applicable facilities
- Locate along an accessible route
- Ensure clear turning circle between 1700 mm (minimum) to 2500 mm (preferred) to allow a person using a wheelchair or mobility device to make a 180-degree turn
- Provide a bench 1830 mm long by 810 mm wide, mounted with top surface between 450 to 500 mm high, designed to carry a minimum load of 1.33kN (300 lb)
- Provide collapsible coat hooks, maximum 50 mm projection, at least two hooks mounted no higher than 1200 mm above floor
- Provide slip-resistant flooring with adequate drainage and bench surface
- Provide full-length mirror minimum 460 mm wide by 1370 mm high, visible from seated and standing positions
- Provide lighting in accordance with Section 5.8 Lighting
- Provide an entrance door or stall door with a clear width of 860 mm minimum when door is in an open position
  - Include a locking mechanism that can be locked from the inside and released from the outside, in case of an emergency
  - Include spring hinges or gravity hinges in the case of a stall door, so that door closes automatically, where the door swings outwards
- Ensure bench, grab bars, and accessories comply with the Amenities section
- Install a full-length mirror at 460 mm wide by 1370 mm high, visible from bench and standing

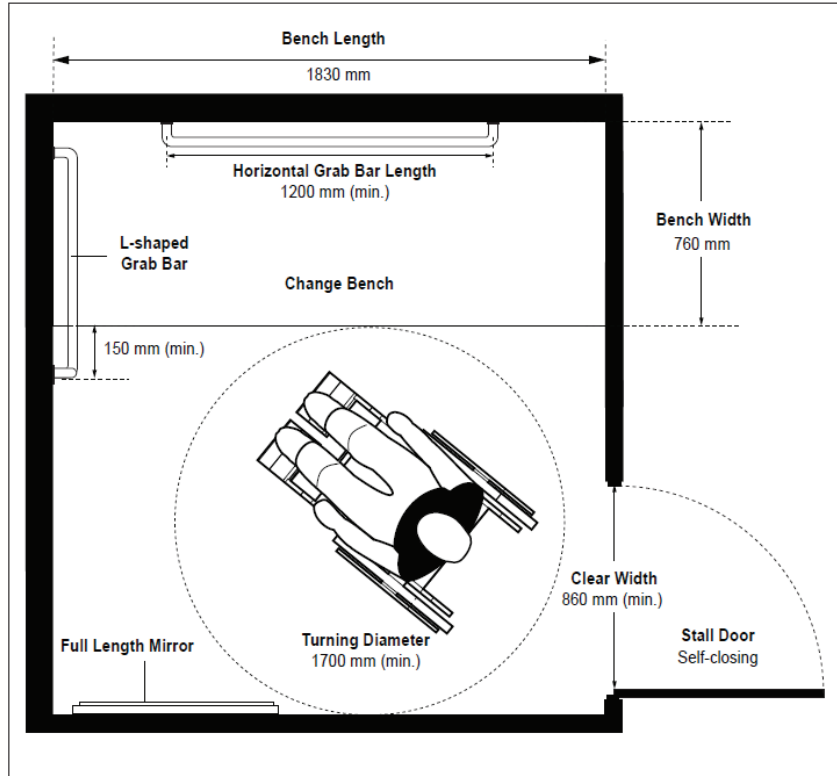

Figure 87: Accessible Changing Stall – Plan View

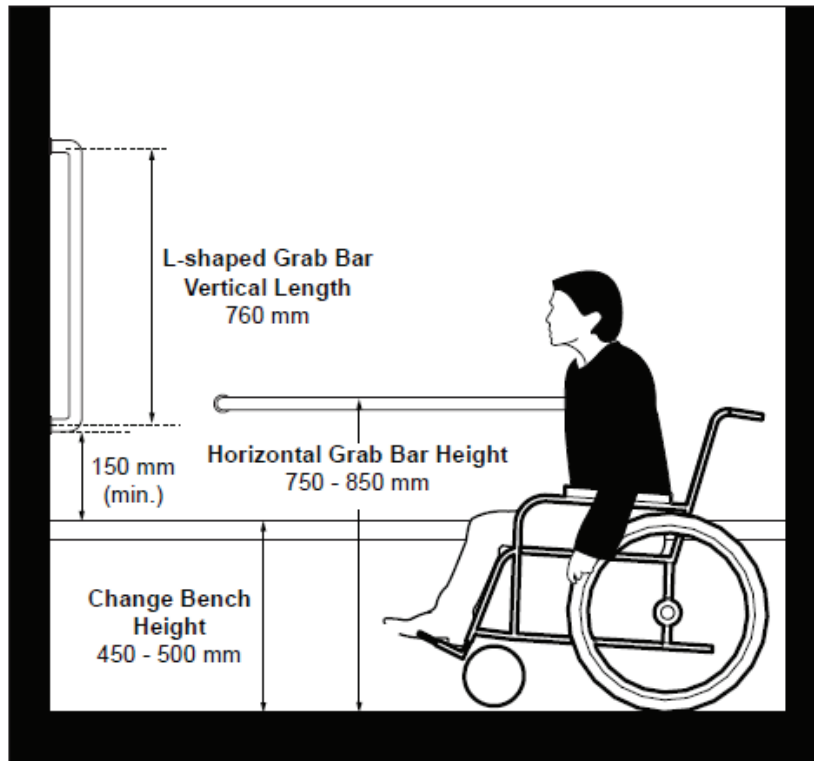

Figure 88: Accessible Changing Stall – Elevation View

## Multiple-Occupancy Change Rooms

- Ensure the entrance to the change room provides a clear width of 860 mm for doors and circulation
- Where doors are provided at the entrance, equip with power door operators
- Provide a consistent accessible path of travel 1100 mm wide throughout the space for circulation
- Ensure a clear turning diameter of 1700 mm (minimum) in the circulation area to allow users of mobility aids to make a 180-degree turn
- Ensure the floor surface is slip-resistant and allows adequate drainage
- Where washroom facilities are provided as part of a change room, provide accessibility design requirements in accordance with Section 3.7 Washrooms
- Where shower facilities are provided as part of a change room, provide accessibility design requirements in accordance with Section 3.8 Showers
- Where changing stalls are provided, ensure at least one accessible changing stall is provided in accordance with this section
- Provide lighting in accordance with Section 5.8 Lighting

## Change Room Amenities

Change room amenities typically include, but are not limited to: benches, lockers, showers, washrooms, and related features (e.g., vanity counters with no lavatories).

### Permanent Benches

Where permanent benches are provided:

- Provide seat height of 450 to 500 mm above finished floor to allow users of mobility aids to transfer
- Ensure seat depth between 510 mm and 610 mm, with back support, unless seat surface is permanently positioned against a wall
- Provide high colour contrast finishes to assist with distinguishing bench surfaces from surroundings

### Lockers

Where lockers are provided inside change rooms:

- Ensure at least 10% of the total number of lockers, but never less than one (both full and half height) is designated as accessible
- Ensure accessible lockers are evenly dispersed throughout the change room
- Identify accessible lockers clearly with signage (e.g., International Symbol of Accessibility)

- Provide clear floor space in front of accessible lockers:
  - 915 mm wide by 1370 mm deep to allow a forward approach
  - 1525 mm wide by 915 mm deep to allow a side approach
- Mount bottom shelf between 400 mm and 1200 mm high from floor in each accessible locker
- Ensure locking mechanism is mounted between 900 mm and 1100 mm above floor
- Ensure identification/number signage for all lockers:
  - Mounted no higher than 1500 mm (centre)
  - Lettering or number print size between 13 mm and 19 mm high, with either raised or recessed lettering
  - High colour contrast with the background

### Coat Hooks

Where coat hooks are provided:

- Ensure at least 10% of coat hooks are collapsible with maximum 50 mm projection and mounted 1200 mm high (maximum)

Note: Where family or childcare needs exist, facilities may include baby change tables and child-sized toilets. These should be accessible and located along accessible routes.

**Table 65: Change Rooms at a Glance**

| <b>Feature / Element</b>   | <b>Universal Change Room</b>   | <b>Accessible / Private Change Room</b>   | <b>Multiple-Occupancy Change Room</b>  |
|----------------------------|--|---|--|
| <b>Use / Purpose</b>       | <ul style="list-style-type: none"> <li>• Gender-neutral, single-use</li> <li>• Accommodates privacy &amp; assistance from opposite sex / parent assisting child</li> </ul> | <ul style="list-style-type: none"> <li>• Private accessible space for individual use</li> <li>• Mobility device friendly</li> </ul> | <ul style="list-style-type: none"> <li>• Group use</li> <li>• Accessible elements integrated</li> </ul>  |
| <b>Quantity / Location</b> | <ul style="list-style-type: none"> <li>• At least 1 wherever team/gender-specific change rooms exist</li> <li>• Centrally located along accessible route</li> </ul>        | <ul style="list-style-type: none"> <li>• At least 1 per cluster of change rooms</li> <li>• Along accessible route</li> </ul>        | <ul style="list-style-type: none"> <li>• Ensure at least 1 accessible stall per cluster</li> <li>• Doors &amp; circulation along accessible route</li> </ul> |
| <b>Door Width / Entry</b>  | <ul style="list-style-type: none"> <li>• 860 mm minimum clear width</li> <li>• Power door operators</li> </ul>   | <ul style="list-style-type: none"> <li>• 860 mm minimum clear width</li> </ul>  | <ul style="list-style-type: none"> <li>• 860 mm clear width</li> <li>• Power door operators where doors provided</li> </ul>                                  |

| Feature / Element                | Universal Change Room   | Accessible / Private Change Room  | Multiple-Occupancy Change Room  |
|----------------------------------|---|---|---|
|                                  |   | <ul style="list-style-type: none"> <li>• Locking mechanism inside, emergency release outside</li> <li>• Spring/gravity hinges</li> </ul>  |   |
| <b>Turning Circle / Diameter</b> | <ul style="list-style-type: none"> <li>• 1700 mm minimum</li> <li>• 2500 mm preferred for 180° wheelchair turn</li> </ul>   | <ul style="list-style-type: none"> <li>• 1700 mm minimum</li> <li>• 2500 mm preferred for 180° wheelchair turn</li> </ul>   | <ul style="list-style-type: none"> <li>• 1700 mm minimum in circulation</li> <li>• 1100 mm accessible path throughout</li> </ul>  |
| <b>Flooring</b>                  | <ul style="list-style-type: none"> <li>• Slip-resistant with adequate drainage</li> </ul>   | <ul style="list-style-type: none"> <li>• Slip-resistant flooring with adequate drainage &amp; bench surface</li> </ul>  | <ul style="list-style-type: none"> <li>• Slip-resistant flooring with adequate drainage</li> </ul>  |
| <b>Bench</b>                     | <ul style="list-style-type: none"> <li>• Refer to Amenities section</li> <li>• Compliant with height/contrast standards</li> </ul>  | <ul style="list-style-type: none"> <li>• 1830 mm long × 810 mm wide</li> <li>• 450–500 mm height</li> <li>• Designed for 1.33 kN (300 lb)</li> </ul>  | <ul style="list-style-type: none"> <li>• As per Amenities</li> <li>• Permanent benches compliant with accessibility standards</li> </ul>  |
| <b>Mirrors</b>                   | <ul style="list-style-type: none"> <li>• Full-length 460 mm × 1370 mm</li> <li>• Visible from bench &amp; standing</li> </ul>   | <ul style="list-style-type: none"> <li>• Full-length 460 mm × 1370 mm</li> <li>• Visible from bench &amp; standing</li> </ul>   | <ul style="list-style-type: none"> <li>• Not specific</li> <li>• Follow Amenities section if provided</li> </ul>  |
| <b>Coat Hooks</b>                | <ul style="list-style-type: none"> <li>• Ensure at least 10% of coat hooks are collapsible</li> <li>• Maximum 50 mm projection</li> <li>• Mounted 1200 mm high (maximum)</li> </ul> | <ul style="list-style-type: none"> <li>• 2 collapsible hooks</li> <li>• Max 50 mm projection</li> <li>• Mounted 1200 mm high (maximum)</li> </ul>   | <ul style="list-style-type: none"> <li>• Ensure at least 10% of coat hooks are collapsible</li> <li>• Maximum 50 mm projection</li> <li>• Mounted 1200 mm high (maximum)</li> </ul> |
| <b>Lockers</b>                   | <ul style="list-style-type: none"> <li>• Refer to Amenities section if provided</li> </ul>  | <ul style="list-style-type: none"> <li>• At least 10% accessible</li> <li>• Evenly dispersed</li> <li>• Clear floor space; shelf 400–1200 mm</li> <li>• Lock 900–1100 mm</li> <li>• Signage ≤1500 mm</li> </ul> | <ul style="list-style-type: none"> <li>• Same as Accessible / Private if lockers provided</li> </ul>  |

| <b>Feature / Element</b>   | <b>Universal Change Room</b>  | <b>Accessible / Private Change Room</b>  | <b>Multiple-Occupancy Change Room</b>   |
|----------------------------|---|--|---|
| <b>Showers / Washrooms</b> | <ul style="list-style-type: none"> <li>Apply Sections 3.7 / 3.8 if part of room</li> </ul>                        | <ul style="list-style-type: none"> <li>Apply Sections 3.7 / 3.8 if part of room</li> </ul> | <ul style="list-style-type: none"> <li>Apply Sections 3.7 / 3.8 if part of room</li> </ul>  |
| <b>Lighting</b>            | <ul style="list-style-type: none"> <li>Section 5.8</li> </ul>   | <ul style="list-style-type: none"> <li>Section 5.8</li> </ul>                              | <ul style="list-style-type: none"> <li>Section 5.8</li> </ul>   |
| <b>Signage</b>             | <ul style="list-style-type: none"> <li>International Symbol of Accessibility</li> <li>Unisex pictogram</li> </ul> | <ul style="list-style-type: none"> <li>International Symbol of Accessibility</li> </ul>    | <ul style="list-style-type: none"> <li>International Symbol of Accessibility</li> </ul>   |
| <b>Optional / Family</b>   | <ul style="list-style-type: none"> <li>N/A</li> </ul>   | <ul style="list-style-type: none"> <li>N/A</li> </ul>                                      | <ul style="list-style-type: none"> <li>Where family/childcare needs exist</li> <li>Baby change tables &amp; child-sized toilets</li> <li>Accessible &amp; along accessible route</li> </ul> |

## 4.1 Parking and Passenger Loading Zones

### Off-Street Parking

#### Rationale

Accessible off-street parking provides safe, convenient, and clearly identifiable parking for people with disabilities, older adults, caregivers, and others with reduced mobility. Properly designed off-street parking ensures safe entry and exit from vehicles, accessible routes to building entrances, and integration with pedestrian pathways.

#### Application

This section applies to all new construction or redevelopment of surface parking lots, structured parking facilities, and private or public off-street parking areas accessible to the public.

#### Requirements

##### Types of off-street accessible parking spaces

Accessible parking spaces should meet the needs of a diverse and growing population of accessible parking permit holders. To meet this need, spaces should allow larger-sized personal vehicles to park and provide additional space when a vehicle is parked next to a wall or obstruction. Accessible parking spaces must be located perpendicular or parallel to the drive aisle.

There are three types of off-street accessible parking spaces:

- Type A Parking: Van Accessible
- Type B Parking: Car Accessible
- Type C Parking: Courtesy/Limited Mobility and Caregiver Parking

Accessible parking spaces must be:

- Type A minimum width 3400 mm
- Type B minimum width 2600 mm
- Type C minimum width 3400 mm
  - When needed – public facing facilities
- Minimum length of 5200 mm
- Minimum height clearance 2750 mm for exterior and 2590 mm for interior

**Table 66: Types of Accessible Parking Spaces**

| Type          | Description                          | Minimum Width | Minimum length | Notes   |
|---------------|--------------------------------------|---------------|----------------|---|
| <b>Type A</b> | Standard accessible parking space    | 3400 mm       | 5200 mm        | Meets minimum legislative requirements  |
| <b>Type B</b> | Van-accessible space                 | 2600 mm       | 5200 mm        | Identified for van-accessible vehicles, meets legislation   |
| <b>Type C</b> | Limited mobility / caregiver parking | 3400 mm       | 5200 mm        | Not legislated, designed for users who need proximity to entrances or assistance with children/companions |

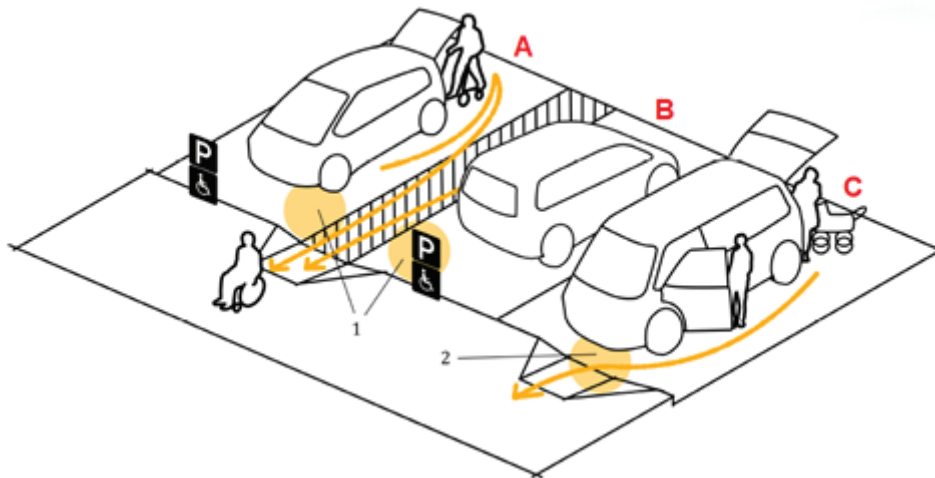

Key

1. Type A and B accessible parking spaces, sharing access route to pathway
2. Type C designated parking space for Courtesy/Limited Mobility and Caregiver parking

**Figure 89: Examples of Parking Spaces with Shared Access Aisle**

## Amount

Accessible parking spaces should be provided in proportion to the total amount of parking spaces available and meet the following criteria:

**Table 67 – Required Number of Type A, B, and C Parking Spaces  
(Based on facility type, additional spaces may be required)**

| Total Number of Parking Spaces | Total Number of Accessible Spaces Required | Number of Type A  | Number of Type B | Number of Type C |
|--------------------------------|--|---|------------------|------------------|
| 1 – 12                         | 1  | 1   | 0                | 0                |
| 13 – 25                        | 1  | 0   | 1                | 0                |
| 26 – 50                        | 2  | 1   | 1                | 0                |
| 51 – 75                        | 3  | 1   | 2                | 0                |
| 76 – 100                       | 4  | 2   | 2                | 0                |
| 101 – 133                      | 5  | 2   | 3                | 0                |
| 134 – 166                      | 6  | 3   | 3                | 0                |
| 167 – 250                      | 7  | 3   | 4                | 0                |
| 251 – 300                      | 8  | 4   | 4                | 0                |
| 301 – 350                      | 9  | 4   | 5                | 0                |
| 351 – 400                      | 10   | 5   | 5                | 0                |
| 401 – 450                      | 11   | 5   | 6                | 0                |
| 451 – 500                      | 12   | 6   | 6                | 0                |
| 501 – 550                      | 13   | 6   | 7                | 0                |
| 551 – 600                      | 14   | 7   | 7                | 0                |
| 601 – 650                      | 15   | 7   | 8                | 0                |
| 651 – 700                      | 16   | 8   | 8                | 0                |
| 701 – 750                      | 17   | 8   | 9                | 0                |
| 751 – 800                      | 18   | 9   | 9                | 0                |
| 801 – 850                      | 19   | 9   | 10               | 0                |
| 851 – 900                      | 20   | 10  | 10               | 0                |
| 901 – 950                      | 21   | 10  | 11               | 0                |
| 951 – 1000                     | 22   | 11  | 11               | 0                |
| 1001 and over                  | 11+1% of total                             | 1. Where an even number is required, provide equal number of Type A and B<br>2. Where an odd number is required, provide equal number of Type A and B plus an additional Type B |                  | 0                |

1. Where only one (1) accessible parking space is required, a Type A accessible parking space shall be provided
2. Where an even number is required, provide an equal number of Type A and B spaces
3. Where an odd number is required, provide equal number of Type A and B plus an additional Type B space
4. There are no required Type C spaces required. The number of spaces should be dependent on the programming of the facility (for example, seniors centre, health care facilities, recreation and community centres and libraries)

In facilities with multiple accessible entrances with adjacent parking, designated parking spaces shall be dispersed and located closest to the accessible entrances.

Where more than one parking facility is provided at a site:

- The number and type of accessible parking spaces provided is calculated individually for each parking facility
- Distribution and location of accessible parking spaces will be done in a manner that provides equivalent or greater accessibility in terms of distance from an accessible entrance or user convenience

Note: Additional parking spaces should be considered in locations where a higher proportion of seniors, older adults or persons using mobility devices is anticipated such as health care facilities, seniors centres and recreation and community centres.

## Access Aisles

Access aisles should be provided to create a designated area where drivers and passengers, including persons using mobility devices, can safely move from their parked vehicle to their desired destination. Access aisles must:

- Be at least 1500 mm wide
- Be clearly marked with high tonal contrast diagonal lines
- Extend the full length of the space
- Connect to an accessible path
- Not cross a vehicular route

Where two accessible spaces are provided adjacent to each other, they may share an access aisle.

**Note: No access aisle required for Type C accessible parking spaces**

## Location

Accessible parking should be located within close proximity to an accessible entrance to ensure persons can access the building safely and efficiently.

Off-street parking should be located:

- Within 30 metres from the nearest accessible entrance
- On at least one level of a multi-storey or underground parking area

## Accessible Path of Travel

An accessible path of travel should be provided to allow for a continuous, unobstructed route providing access to elements and spaces. Accessible paths of travel must:

- Be provided from the accessible building entrance to accessible parking spaces
  - Spaces should provide a direct view of the entrance. Where a direct view is not provided, provide signage to direct to the accessible entrance

- Not enter vehicle traffic and should be as short as possible
- Where required, provide curb ramps or depressed curbs that meet Section 4.4 Curb Ramps and Depressed Curbs
- Tactile Walking Surface Indicators (TWSI) should be provided to lead persons with vision impairments to the main entrance where no other clues indicate the path to the building (see example in Figure 41 and requirements in Section 2.8 Tactile Walking Surface Indicators)

## Parallel Parking Spaces

Off-street parking should provide accessible parallel parking spaces that:

- Are at least 7250 mm in length
- Are 4600 mm wide
- In retrofit situations where it is technically infeasible to provide a 4600 mm width, the width may be reduced to match the width of adjacent spaces
- Where possible, provide a clear space of at least 2440 mm by 2440 mm at the curb level, adjacent to the passenger side
- Provide detectable warning surfaces or contrasting pavement at curb edges to assist persons with low vision

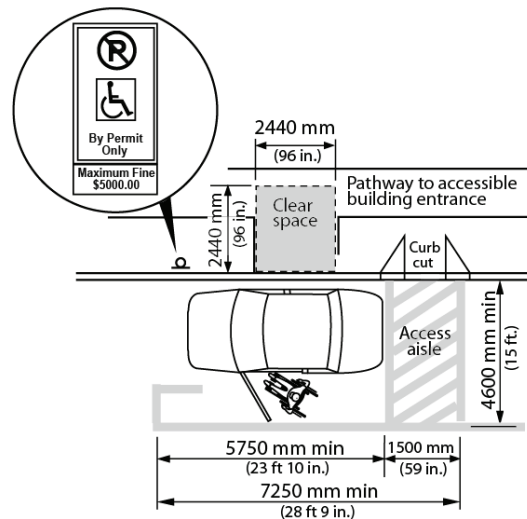

Figure 90: Side-by-side Parking Space

## Surface and Slope

A level ground surface should be provided to reduce the risk of tripping hazards and the potential discomfort experienced by persons using mobility devices or a white cane. Accessible parking spaces, access aisles and the accessible path must:

- Firm, stable and slip-resistant surface

- Maximum slope: 1:20 (5%)
- Maximum cross slope: 1:50 (2%)

## Pavement Markings

Pavement markings should be provided for accessible parking spaces and access aisles to clearly identify the designated areas. Pavement markings must:

- Be slip resistant
- Have the Dynamic Symbol of Access that has
  - Pavement markings including a 1525 x 1525 white border and symbol with a blue background field colour (Figure 24)
- Have the Courtesy/Limited Mobility and Caregiver symbol in accordance with Figure 25



**Figure 91: Dynamic Symbol of Access**

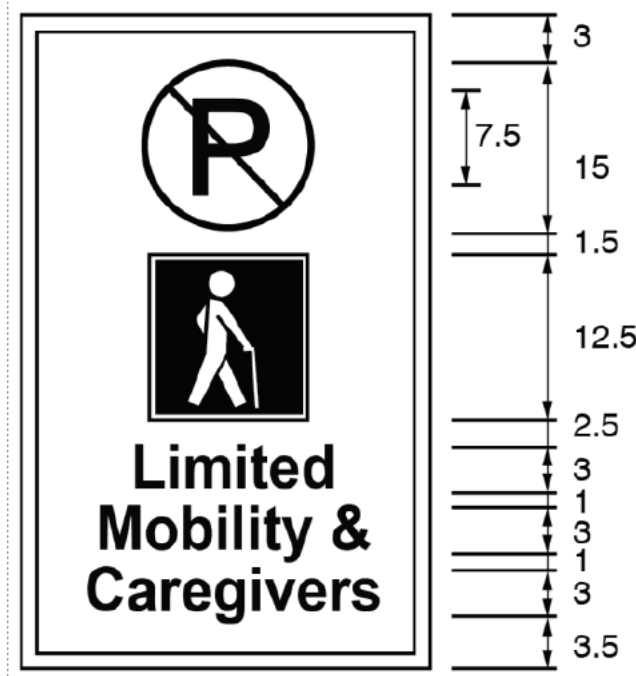
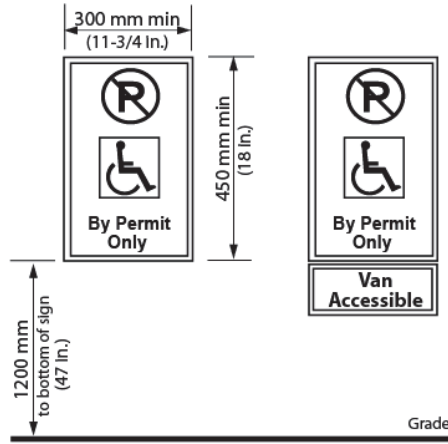

**Figure 92: Type C Accessible Parking Space (Limited Mobility and Caregivers)**

## Signage

Signage for accessible parking spaces should be clearly designated with vertical signage containing the International Symbol of Accessibility. Each accessible parking space shall be designated with signage that:

- Has the International Symbol of Access
- Is mounted vertically in a permanent manner
  - If mounted on a post, the post shall be colour contrasted with the background environment
- Is at least 300 mm wide x 450 mm high
- Is installed at a height of 1200 mm from the ground/floor surface to the bottom edge of the sign
- Type A parking spaces must include two parking signs, one indicating by Permit Only and the second indicating Van Accessible
- Type B parking spaces must include parking signage indicating by Permit Only
- Type C parking spaces must include parking signage indicating Limited Mobility and Caregivers
- For perpendicular parking, centred on the parking space
- For parallel parking, located toward the end of the parking space, on the opposite side from the access aisle

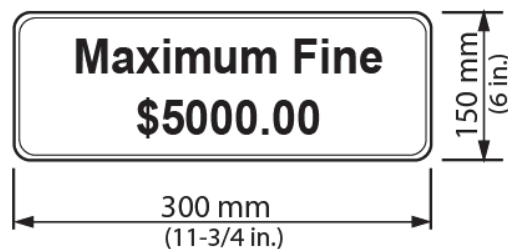

**Figure 93: Regulatory Parking Signage**



**Figure 94: Type-C Parking Signage**

A second sign to deter illegal usage of the accessible parking space is recommended to be mounted below the regulated sign outlined in figure 27, noting the maximum fine of \$5000.



**Figure 95: Second Accessible Parking Signage**

### Indoor Accessible Parking

In addition to meeting all of the off-street parking requirements above, indoor parking must also:

- Incorporate a sign at the vehicle entrance indicating the minimum overhead clearance at the parking space and along the vehicle access and egress routes

- The minimum height at the entrance to a parking facility should be a minimum of 2400 mm
- While 2400 mm is preferred, Ontario Building Code (OBC) stipulates that the minimum unobstructed height of a below grade parking structure is 2100 mm. In a retrofit situation where it is technically infeasible, use OBC dimensions
- Post signage at the vehicle entrance indicating the location of the designated accessible parking spaces. If an indoor parking facility is not accessible, suitable warnings should be provided at the entrance and alternative designated parking spaces provided outside of the building
- Locate accessible spaces near accessible entrances, elevators or ramps
- Provide accessible parking spaces on at least one level of a multi-storey or underground parking area and on the same level as the main entrance or other entrance to the building

### **Ticketing and Payment Machines**

Ticketing dispensers should be provided that:

- Are connected to an exterior accessible path of travel
- Have an adjacent clear ground space of 900 mm by 1500 mm
- Are located:
  - In close proximity to the available accessible parking spaces
  - In well-lit areas for safety and legibility of the device
- Have controls and operating mechanisms that meet the requirements of Section 5.1 Controls and Operating Mechanisms and 5.10 Self-service Kiosks

## On-Street Parking

### Rationale

Accessible on-street parking provides safe and convenient vehicle access for individuals using mobility devices, older adults, caregivers, and others with medical conditions. These spaces support safe entry and exit and facilitate a connection to accessible pathways and destinations.

### Application

This section applies to all new construction or redevelopment of on-street parking spaces.

### Consultation

When constructing new or redeveloping existing on-street parking spaces, consultation on the need, location and design of accessible on-street parking spaces must occur with:

- The public and persons with disabilities
- The Mississauga Accessibility Advisory Committee
- All relevant City staff

Accessible parallel on-street parking should:

- Be at least 7250 mm in length and 4600 mm in width
  - In retrofit situations where 4600 mm is not feasible, match the depth to adjacent parking spaces
- Provide a clear space at curb level of at least 2440 mm by 2440 mm adjacent to the passenger side

## Passenger Loading Zones

### Rationale

Accessible passenger-loading zones provide safe, short-term vehicle stopping areas for individuals using mobility aids, those with limited mobility, and people accompanied by caregivers. These zones facilitate safe boarding and alighting, including space for lifts, ramps, and required clearances

### Application

This section applies to passenger loading zones provided for:

- Personal vehicles
- Public transit vehicles
- Taxis or ride-shares
- Valet or service parking

At least one accessible passenger-loading zone must comply with these requirements where loading zones are provided.

### Requirements

#### Location

Passenger loading zones must:

- Be within 30 metres from the main or any accessible entrance
- Be near ramps if ramps are part of the entrance
- Avoid traffic routes and drive aisles
- On an accessible route complying with Section 4.2 Accessible Paths of Travel
- Include a depressed curb complying with Section 4.4 Curb Ramps and Depressed Curbs

#### Design

The design should provide space for larger vehicles to access the lay-by space and include overhead clearance from objects such as trees, signage and canopies.

Passenger loading zones must:

- Provide a vehicle pull-up space that is 3400 mm wide and 9000 mm long
- Include an access aisle adjacent and parallel to the vehicle pull-up space:
  - Minimum 2440 mm wide and 7400 mm long

- Reduced to 2000 mm wide in retrofit situations where technically infeasible
- Separate access aisle from walkway with either:
  - A curb containing a curb ramp meeting Section 4.4 Curb Ramps and Depressed Curbs
  - A detectable warning surface that complies with Section 2.8 Tactile Walking Surface Indicators
- Connect to an accessible path of travel
- Maintain a minimum vertical clearance of 3600 mm at the vehicle pull-up space and along access/egress routes
- Provide seating near boarding points on larger premises (see Section 2.7 Rest Areas)

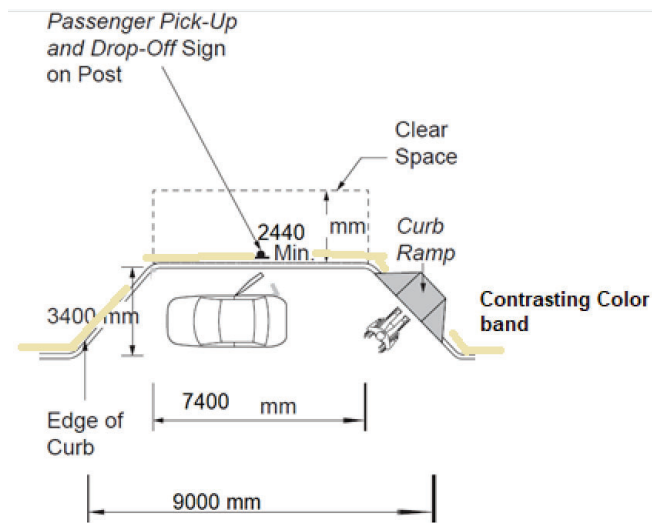

**Figure 96: Passenger Loading Zone with Curb Ramp**

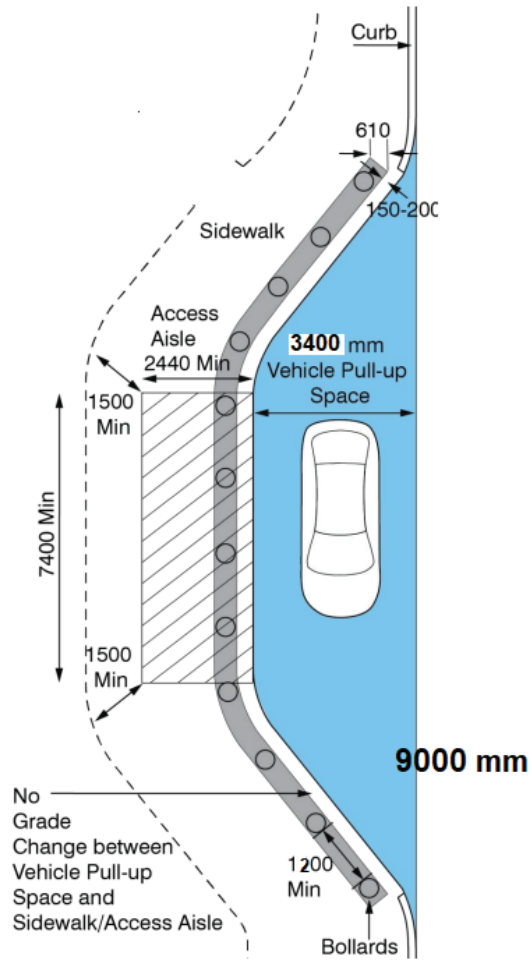

**Figure 97: Passenger Loading Zone - Depressed Curb**

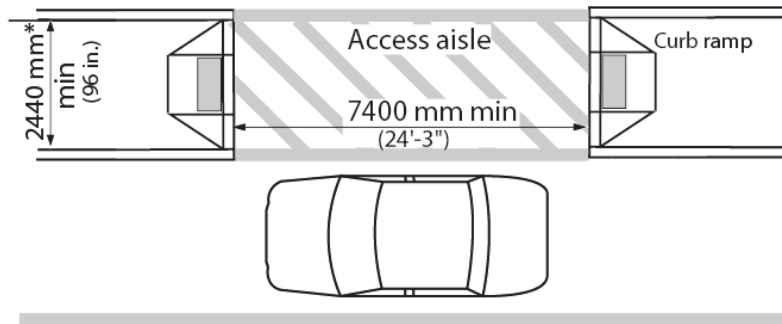

**Figure 98: Alternate Passenger Loading Zone Configuration**

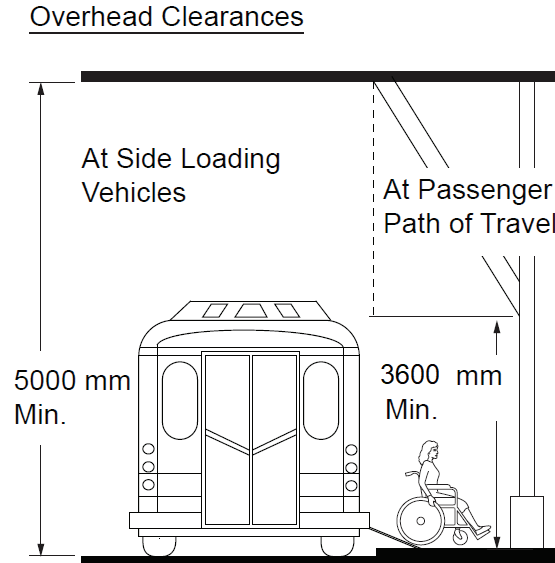

**Figure 99: Clearances at Passenger Loading Zone**

### Signage and Pavement Markings

- Diagonal pavement markings with high colour contrast to define spaces
- Exempt in locations where there is unpaved or trail surfaces such as in parking lots found in the trail systems or parks
- Vertical signage must include the International Symbol of Accessibility and indicate “passenger pick-up and drop-off only, no parking” or “designated passenger loading zone”
- Meet the criteria in Section 5.7 Signage and Wayfinding Systems

### Bollards and Tactile Attention Indicator Surfaces

Where the access aisle is not separated by a curb:

- Install TAI surfaces detectable by foot or cane
- Use high tonal/colour contrast
- Extend the full length of the space
- Comply with tactile walking surface indicator standards (see Section 2.8 Tactile Walking Surface Indicators)

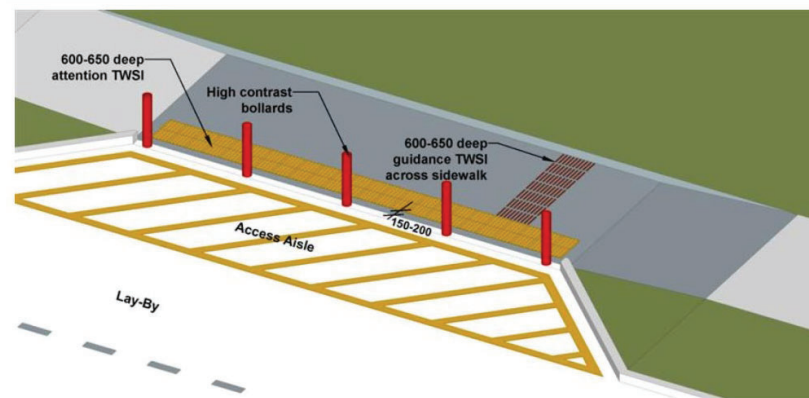

Figure 100: A Depressed Curb at a Vehicular Loading Zone

Table 68: Parking and Loading Zones at a Glance

| Element   | Key Requirements  | Minimum Dimensions   | Notes / Additional Info  | Visual Reference   |
|---|---|--|--|--|
| <b>Off-Street Parking – Type A (Van Accessible)</b>               | <ul style="list-style-type: none"> <li>Standard accessible parking space, meets legislation</li> </ul>            | <ul style="list-style-type: none"> <li>Width: 3400 mm</li> <li>Length: 5200 mm</li> <li>Height clearance:                             <ul style="list-style-type: none"> <li>Exterior: 2750 mm</li> <li>Interior: 2590 mm</li> </ul> </li> </ul> | <ul style="list-style-type: none"> <li>Must include two parking signs:                             <ul style="list-style-type: none"> <li>Permit Only</li> <li>Van Accessible</li> </ul> </li> </ul> | <ul style="list-style-type: none"> <li>Fig 42</li> <li>Fig 43</li> </ul>                                 |
| <b>Off-Street Parking – Type B</b>                                | <ul style="list-style-type: none"> <li>Van-accessible space</li> </ul>  | <ul style="list-style-type: none"> <li>Width: 2600 mm</li> <li>Length: 5200 mm</li> <li>Height clearance:                             <ul style="list-style-type: none"> <li>Exterior 2750 mm</li> <li>Interior 2590 mm</li> </ul> </li> </ul>   | <ul style="list-style-type: none"> <li>Parking signage:                             <ul style="list-style-type: none"> <li>Permit Only</li> </ul> </li> </ul>  | <ul style="list-style-type: none"> <li>Fig 42</li> <li>Fig 43</li> </ul>                                 |
| <b>Off-Street Parking – Type C (Limited Mobility / Caregiver)</b> | <ul style="list-style-type: none"> <li>Courtesy/Limited mobility or caregiver parking (not legislated)</li> </ul> | <ul style="list-style-type: none"> <li>Width: 3400 mm</li> <li>Length: 5200 mm</li> <li>Height clearance:                             <ul style="list-style-type: none"> <li>Exterior 2750 mm</li> <li>Interior</li> </ul> </li> </ul>           | <ul style="list-style-type: none"> <li>Minimums only;</li> <li>Adjust based on facility type</li> <li>Signage: Limited Mobility &amp; Caregivers</li> </ul>  | <ul style="list-style-type: none"> <li>Fig 42</li> <li>Fig 43</li> <li>Fig 46</li> <li>Fig 48</li> </ul> |

| Element                             | Key Requirements  | Minimum Dimensions   | Notes / Additional Info   | Visual Reference   |
|-------------------------------------|---|--|---|--|
|                                     |   | 2590 mm  |   |  |
| <b>Access Aisle</b>                 | <ul style="list-style-type: none"> <li>Designated area for vehicle exits and mobility device access</li> </ul>                              | <ul style="list-style-type: none"> <li>Width: 1500 mm (shared if two spaces adjacent)</li> <li>Extend full length of space</li> </ul>  | <ul style="list-style-type: none"> <li>Not required for Type C</li> </ul>   | <ul style="list-style-type: none"> <li>Fig 42</li> </ul>                 |
| <b>Accessible Path of Travel</b>    | <ul style="list-style-type: none"> <li>Continuous, unobstructed route from parking to building</li> </ul>                                   | <ul style="list-style-type: none"> <li>See Section 4.2 Exterior Accessible Paths of Travel</li> </ul>                                  | <ul style="list-style-type: none"> <li>Must avoid vehicle traffic</li> <li>Where required, provide: <ul style="list-style-type: none"> <li>Curb ramps</li> <li>Depressed curbs</li> <li>TWSI</li> </ul> </li> </ul> | <ul style="list-style-type: none"> <li>Fig 43</li> </ul>                 |
| <b>Parallel Off-Street Parking</b>  | <ul style="list-style-type: none"> <li>Accessible where parallel parking provided</li> </ul>  | <ul style="list-style-type: none"> <li>Length: 7250 mm</li> <li>Width: 4600 mm</li> <li>Clear space at curb: 2440 x 2440 mm</li> </ul> | <ul style="list-style-type: none"> <li>Width may be reduced in retrofit situations</li> </ul>   | <ul style="list-style-type: none"> <li>Fig 44</li> </ul>                 |
| <b>Surface &amp; Slope</b>          | <ul style="list-style-type: none"> <li>Firm, stable, slip-resistant</li> </ul>  | <ul style="list-style-type: none"> <li>Max slope: 1:20 (5%)</li> <li>Max cross slope: 1:50 (2%)</li> </ul>                             | <ul style="list-style-type: none"> <li>Applies to spaces, aisles, paths</li> </ul>  |  |
| <b>Pavement Markings</b>            | <ul style="list-style-type: none"> <li>Dynamic Symbol of Access</li> <li>Type C: Courtesy/Limited Mobility and Caregiver Parking</li> </ul> | <ul style="list-style-type: none"> <li>Size: 1525 x 1525 mm white border with blue background</li> </ul>                               | <ul style="list-style-type: none"> <li>Slip-resistant</li> </ul>  | <ul style="list-style-type: none"> <li>Fig 45</li> <li>Fig 46</li> </ul> |
| <b>Indoor Parking</b>               | <ul style="list-style-type: none"> <li>Overhead clearance signage</li> <li>Locate spaces near accessible entrances/elevators</li> </ul>     | <ul style="list-style-type: none"> <li>Min height at entrance: 2400 mm (preferred)</li> <li>OBC min 2100 mm</li> </ul>                 | <ul style="list-style-type: none"> <li>Provide warnings if indoor facility inaccessible</li> </ul>  |  |
| <b>Ticketing / Payment Machines</b> | <ul style="list-style-type: none"> <li>Connect to accessible path</li> <li>Clear space</li> <li>Accessible controls</li> </ul>              | <ul style="list-style-type: none"> <li>Clear space: 900 x 1500 mm</li> </ul>   | <ul style="list-style-type: none"> <li>Located near accessible spaces</li> <li>Well-lit</li> <li>Compliant controls</li> </ul>  |  |
| <b>On-Street Parking</b>            | <ul style="list-style-type: none"> <li>Parallel on-street spaces for accessible</li> </ul>  | <ul style="list-style-type: none"> <li>Length: 7250 mm</li> </ul>  | <ul style="list-style-type: none"> <li>Width may match adjacent spaces if</li> </ul>  | <ul style="list-style-type: none"> <li>Fig 46</li> </ul>                 |

| Element                                | Key Requirements   | Minimum Dimensions   | Notes / Additional Info  | Visual Reference  |
|--|--|--|--|---|
|  | vehicles   | <ul style="list-style-type: none"> <li>• Width: 4600 mm</li> <li>• Clear space at curb: 2440 x 2440 mm</li> </ul>  | infeasible   |   |
| <b>Passenger Loading Zones</b>         | <ul style="list-style-type: none"> <li>• Accessible short-term stopping for vehicles</li> </ul>  | <ul style="list-style-type: none"> <li>• Pull-up space: 3400 mm width, 9000 mm length</li> <li>• Access aisle: 2440 mm wide x 7400 mm long (retrofit 2000 mm width)</li> <li>• Vertical clearance 3600 mm</li> </ul> | <ul style="list-style-type: none"> <li>• Connect to accessible path</li> <li>• Seating near boarding points on larger premises</li> </ul>  | <ul style="list-style-type: none"> <li>• Fig 47–50</li> </ul> |
| <b>Passenger Loading Zone Markings</b> | <ul style="list-style-type: none"> <li>• Diagonal high-contrast markings</li> <li>• Vertical signage with International Symbol of Accessibility</li> </ul> |  | <ul style="list-style-type: none"> <li>• Indicate “passenger pick-up and drop-off only” or “designated passenger loading zone”</li> <li>• Use TAI surfaces if aisle not separated by curb</li> </ul> | <ul style="list-style-type: none"> <li>• Fig 51</li> </ul>    |

## 4.2 Accessible Paths of Travel

### Rationale

Exterior paths of travel provide safe, accessible, and continuous routes for all individuals, including people using mobility devices, those pushing strollers and individuals with temporary or permanent medical conditions.

These paths ensure equitable access to key site features, including:

- Arrival points and accessible parking
- Building entrances and exits
- Facilities, amenities, and elements on site
- Public transit stops and passenger drop-off points

Providing exterior accessible paths of travel follows universal design principles by supporting independence, safety and ease of navigation for all users. Accessible routes should be as direct as possible from site entrances or parking areas to main building entrances.

### Application

This section applies to:

- Pedestrian circulation serving facility entrances, exits, elements, or amenities
- Connections between a site boundary and facility entrances/exits
- Public right-of-ways (e.g., sidewalks, footpaths)
- Ramps, curb ramps and depressed curbs

### General Requirements

#### Ground Surfaces

- Firm, stable, slip-resistant, smooth, level and non-glare
- Provide proper drainage to prevent water accumulation
- Highlight changes in level using contrasting surfaces or bands

#### Headroom

- Minimum clearance of 2100 mm

## Lighting

- Minimum lighting of 50 lux (5 foot-candles) along stairs, ramps and rest areas
- Refer to Section 5.8 Lighting for additional guidance

## Visual Contrast and Wayfinding

- Provide a minimum 70% colour contrast to distinguish path edges, where feasible
- All visual information, including signage, must contrast with the background
- Where vehicle or cycle separation is required:
  - Use curbs, railings or barriers
  - Where separation is not possible, provide tactile walking surface indicators (TWSI) or other high-contrast tactile guidance
  - Provide pedestrian crossings as needed (See Section 4.4 Pedestrian Crossings and Signals)

## Stairs

- Where stairs are present, provide an immediately adjacent accessible alternative (e.g., ramp or other accessible means)

## Clear Width

- Minimum clear width: 1800 mm (See Figure 101)
  - If constricted by localized obstructions (e.g., trees, walls), minimum width may reduce to 1200 mm at the obstruction only
  - Width must return to 1800 mm before and after obstruction
- Passing Areas:
  - Minimum 1800 mm x 1800 mm
  - Located every 30 m, where feasible (See Figure 101)
- Changes in direction:
  - 45°: unobstructed maneuvering space 1500 mm × 1500 mm (See Figure 103)
  - 180° turn: minimum 2000 mm clear space (See Figures 104)
- Paths must remain free of protrusions or overhead objects (See Section 2.6 Overhanging and Protruding Objects)
- Provide a 300 mm offset and contrasting surface next to obstacles

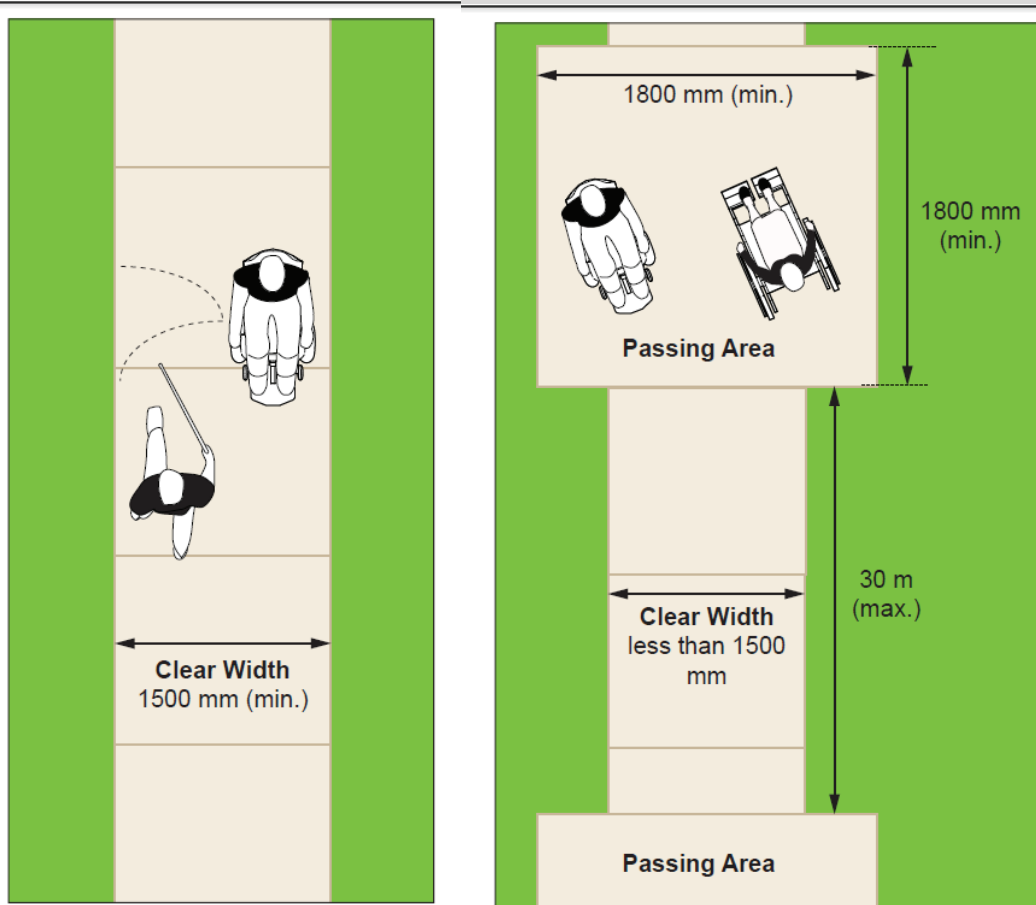
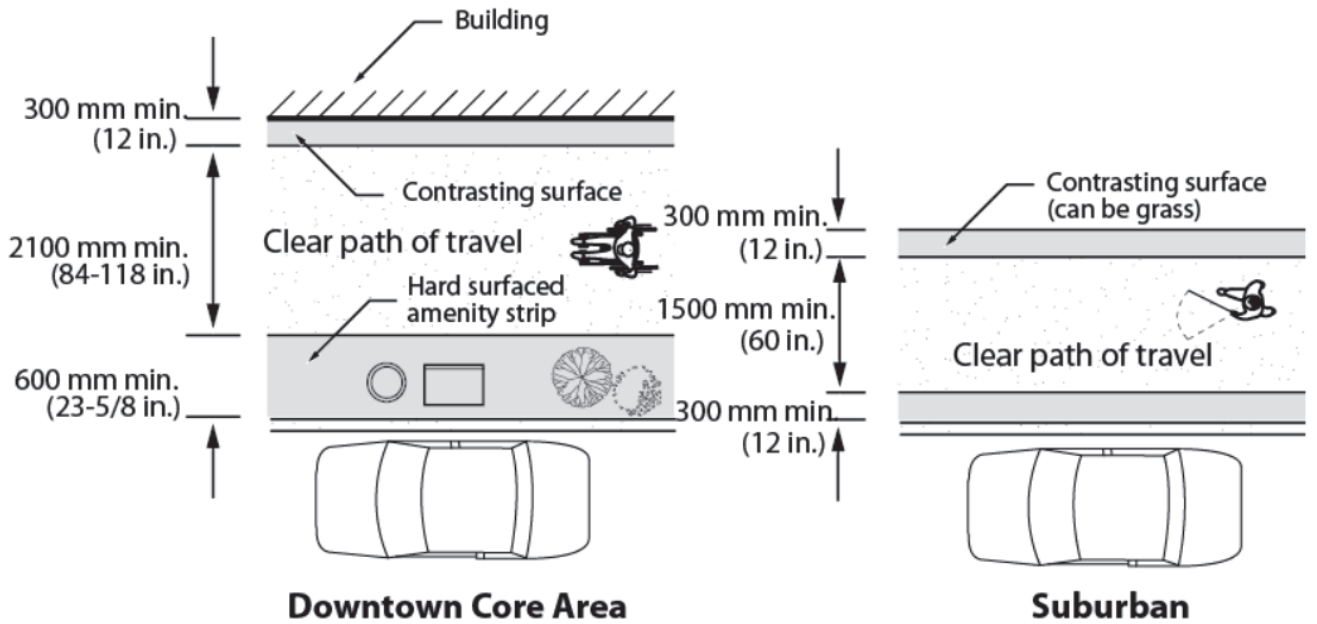

Figure 101: Clear width and passing area



**Downtown Core Area**  
**Suburban**  
 Figure 102: Typical Streetscape Configurations

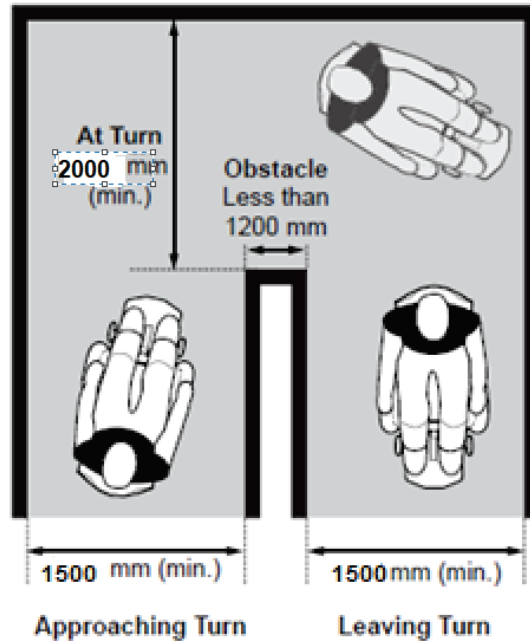

Figure 103: 180 Degree Turn Around Obstacle Less Than 1200 mm

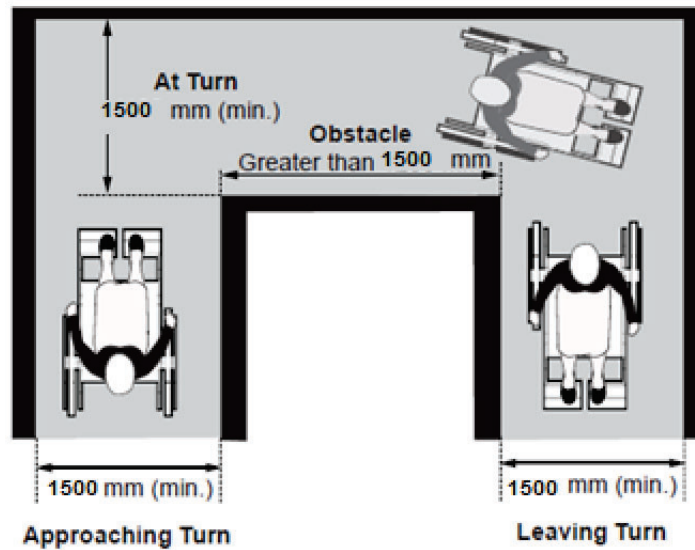

Figure104: 180 Degree Turn Around Obstacle Greater Than 1200 mm

### Slopes

Where slopes are provided on exterior paths of travel, they should be designed to have a gradual transition to allow for better control and ease of movement for people using mobility devices.

## Running Slope

- Maximum 1:20 (5%)
- On sidewalks, slope may exceed 1:20 if  $\leq$  adjacent roadway slope
- Slopes steeper than 1:20 must be designed as ramps per Section 2.3 Ramps

## Cross Slope

- Maximum 1:50 (2%)

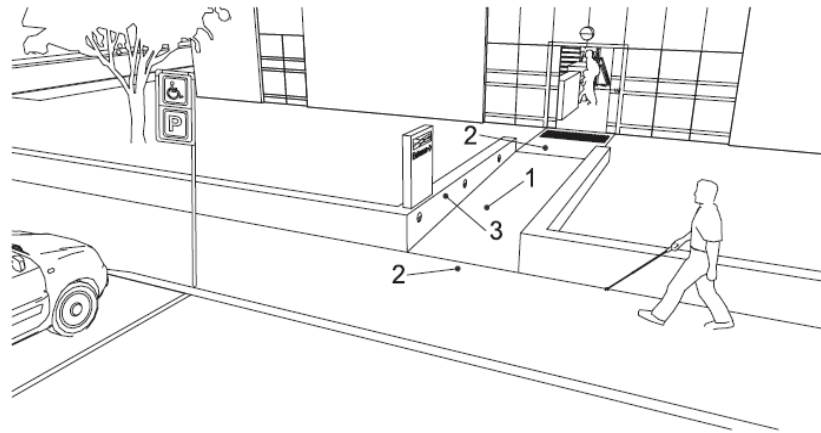

### Key

1. Sloping path for gradients steeper than 1:20 (5 %), specifications on ramps apply
2. Horizontal landing at both ends, intermediate landings per Table XXXX
3. Walls may act as tactile clues

**Figure 105: Example of a Sloping Path**

## Changes in Level

- Elevation changes must be accessible and safe
- Gradual transitions preferred for mobility device users
- Slopes must meet requirements in Table 1:

**Table 69 – Change in Level – Slope Requirements**

| Change in level (height) | Slope requirements                             |
|--------------------------|--|
| 1-5 mm                   | No bevel required                              |
| 6-13 mm                  | 1:2 bevel                                      |
| 14-74 mm                 | Maximum running slope 1:8 (12.5%) or curb ramp |

|                  |   |
|------------------|---|
| 75-200 mm        | Maximum running slope 1:10 (10%) or curb ramp |
| More than 200 mm | Ramp required                                 |

## Edge Protection

- Change in elevation <600 mm:
  - Curb or barrier minimum 75 mm height × 50 mm width, minimum 70% colour contrast
- Change in elevation >600 mm:
  - Handrails and/or guards at 1070 mm
  - Guards per Section 2.4 Stairs
  - Handrails per Section 2.5 Handrails

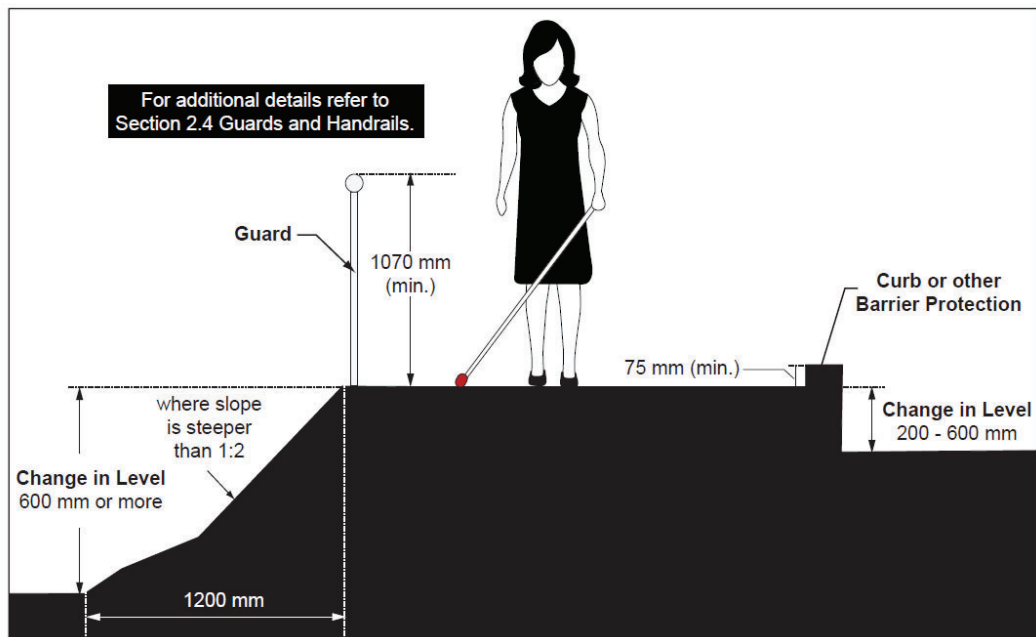
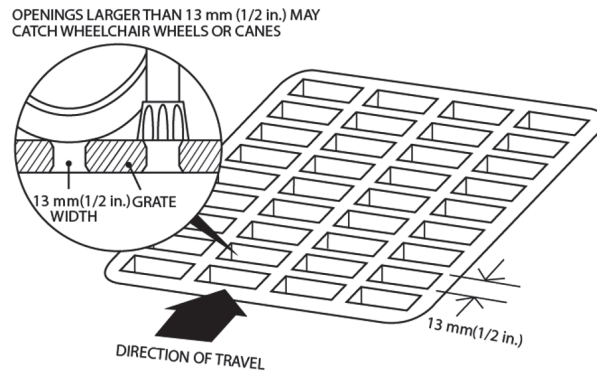

Figure 106: Edge Protection Cross-Section

## Surface Requirements

- Firm, level, stable, slip-resistant, smooth, non-glare
- Contrast with adjacent surfaces where feasible
- Highlight level changes with bands or contrasting materials
- Have openings that:
  - Are perpendicular to direction of travel

- Are maximum 13 mm wide
- Are located outside accessible path (See Figures 10–13)



**Figure 107: Dimension of grating openings (previously 4.1.2.2)**

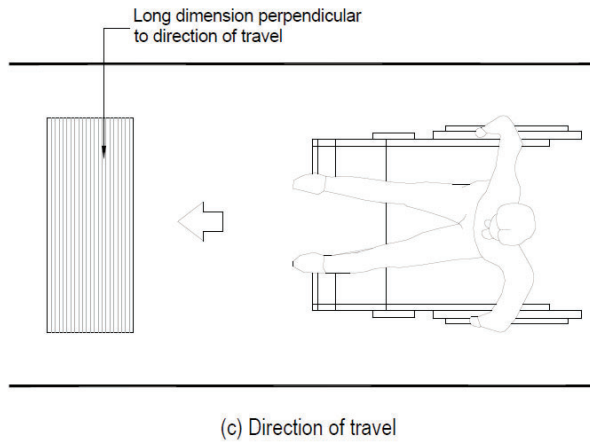

**Figure 108: Grating Orientation Relative to Direction of Travel**

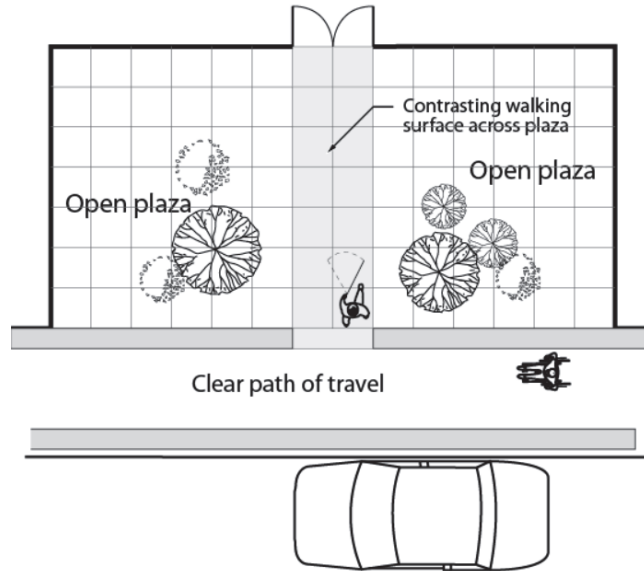

**Figure 109: Contrasting Surface Across an Open Plaza**

### Signage, Orientation and Wayfinding

- Must meet criteria in Section 5.9 Signage and Wayfinding
- Supports independent navigation and orientation for all users

**Table 70: Accessible Exterior Paths of Travel – at a Glance**

| Feature / Element                       | Minimum / Recommended Dimensions   | Notes / Key Requirements   |
|---|--|--|
| <b>Ground Surface</b>                   | <ul style="list-style-type: none"> <li>• Firm, stable, slip-resistant, smooth, non-glare</li> </ul>                | <ul style="list-style-type: none"> <li>• Provide drainage to prevent accumulation</li> <li>• Highlight changes in level with contrast</li> </ul>               |
| <b>Headroom</b>                         | <ul style="list-style-type: none"> <li>• ≥ 2100 mm</li> </ul>  | <ul style="list-style-type: none"> <li>• Provide guards if &lt;2100 mm clearance</li> </ul>  |
| <b>Lighting</b>                         | <ul style="list-style-type: none"> <li>• ≥ 50 lux</li> </ul>   | <ul style="list-style-type: none"> <li>• Along stairs, ramps, and rest areas</li> <li>• See Section 5.8 Lighting</li> </ul>                                    |
| <b>Visual Contrast &amp; Wayfinding</b> | <ul style="list-style-type: none"> <li>• ≥ 70% contrast for path edges</li> </ul>                                  | <ul style="list-style-type: none"> <li>• Use curbs, barriers, or railings for separation</li> <li>• Where not possible, use TWSIs</li> </ul>                   |
| <b>Stairs</b>                           | <ul style="list-style-type: none"> <li>• Accessible alternative required</li> </ul>                                | <ul style="list-style-type: none"> <li>• Adjacent ramp or elevating device must be provided</li> </ul>   |
| <b>Clear Width</b>                      | <ul style="list-style-type: none"> <li>• Primary width: 1800 mm</li> <li>• Local constriction: ≥1200 mm</li> </ul> | <ul style="list-style-type: none"> <li>• Must return to 1800 mm before/after obstruction</li> <li>• Passing areas: 1800 × 1800 mm at 30 m intervals</li> </ul> |

| Feature / Element    | Minimum / Recommended Dimensions  | Notes / Key Requirements  |
|----------------------|---|---|
| Turning Space        | <ul style="list-style-type: none"> <li>• 45°: 1500 × 1500 mm</li> <li>• 180°: ≥2000 mm clear space</li> </ul>   | <ul style="list-style-type: none"> <li>• Ensure unobstructed maneuvering</li> <li>• See Figures 3–5</li> </ul>  |
| Running Slope        | <ul style="list-style-type: none"> <li>• ≤ 1:20 (5%)</li> </ul>   | <ul style="list-style-type: none"> <li>• Slopes &gt;1:20 must comply with ramps (Sec. 2.3)</li> </ul>           |
| Cross Slope          | <ul style="list-style-type: none"> <li>• ≤ 1:50 (2%)</li> </ul>   | <ul style="list-style-type: none"> <li>• Applies to all paths</li> </ul>  |
| Changes in Level     | <ul style="list-style-type: none"> <li>• 1–5 mm: no bevel</li> <li>• 6–13 mm: 1:2 bevel</li> <li>• 14–74 mm: slope ≤1:</li> <li>• 875–200 mm: slope ≤1:10&gt;</li> <li>• 200 mm: ramp required</li> </ul> | <ul style="list-style-type: none"> <li>• Gradual transitions preferred for mobility device users</li> </ul>     |
| Edge Protection      | <ul style="list-style-type: none"> <li>• &lt;600 mm drop: curb/barrier</li> <li>• ≥75 mm high × 50 mm wide, ≥70% contrast&gt;</li> <li>• 600 mm drop: handrails/guards at 1070 mm</li> </ul>              | <ul style="list-style-type: none"> <li>• Guards per Section 2.4</li> <li>• Handrails per Section 2.5</li> </ul> |
| Surface Openings     | <ul style="list-style-type: none"> <li>• ≤13 mm wide, perpendicular to travel direction</li> </ul>  | <ul style="list-style-type: none"> <li>• Gratings and openings located outside accessible path</li> </ul>       |
| Signage & Wayfinding | <ul style="list-style-type: none"> <li>• Comply with Section 5.9</li> </ul>   | <ul style="list-style-type: none"> <li>• Provide independent navigation cues</li> </ul>                         |

## 4.3 External Recreational Routes

### Rationale

Accessible recreational routes allow people of all abilities to safely and comfortably enjoy outdoor natural and recreational spaces. This includes trails, beach access routes, and boardwalks. Accessible design supports individuals who use mobility devices, have limited vision or hearing, or have difficulty with balance or stamina. It ensures recreational areas are inclusive, safe, and enjoyable for all community members.

### Application

This section applies to newly constructed and redeveloped:

- Recreational trails
- Beach access routes
- Boardwalks

That the City intends to maintain.

This section does **not** apply to:

- Trails intended for cross-country skiing, mountain biking or motorized vehicles
- Wilderness, backcountry or portage trails
- Areas protected under heritage or environmental legislation where accessibility requirements would adversely affect the environment or are impossible due to site constraints

### A. Recreational Trails

#### Consultation Requirements

Before construction or redevelopment of recreational trails the City will consult with:

- Mississauga Accessibility Advisory Committee
- The public
- People with disabilities

On:

- Slope and ramp requirements
- Locations and design of rest areas, passing areas and viewing areas
- Placement and type of amenities
- Other relevant features

## Entrances and Exits

- Provide a minimum 1000 mm clear width at trail entrances and exits
- Ensure entrances are maintained and clear of obstructions
- Gates, bollards and other entrance designs must not reduce the required width

## Clear Width and Passing Areas

- Minimum trail width: 1000 mm
- Where possible, passing areas 1800 mm × 1800 mm required at 30 m intervals where the trail width is less than 1800 mm

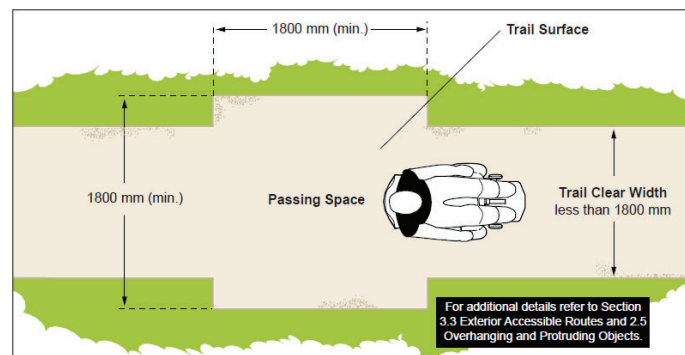

Figure 113: Trail Clear Width

## Headroom

- Minimum headroom clearance: 2100 mm
- Maintain routes free of obstacles and protrusions

## Surface Requirements

- Surfaces must be firm and stable
- Openings must not permit passage of an object that has a diameter of more than 20 mm

## Slopes

- Running slope:
  - Where possible, should be no greater than 1:20 (5%)
    - Where this is not possible due to site constraints, a 1:10 (10%) slope is acceptable
    - If greater than 10%, consult with the AAC
  - Cross slope as gentle as possible, ensure stability and drainage

## Edge Protection

Required where trails run immediately adjacent to water or a drop-offs

- Minimum height: 50 mm
- Ensure colour contrast for visibility
- Must not impede drainage

**Note:** Where there is a protective barrier that runs along the edge of a recreational trail that is adjacent to water or a drop-off, edge protection does not have to be provided.

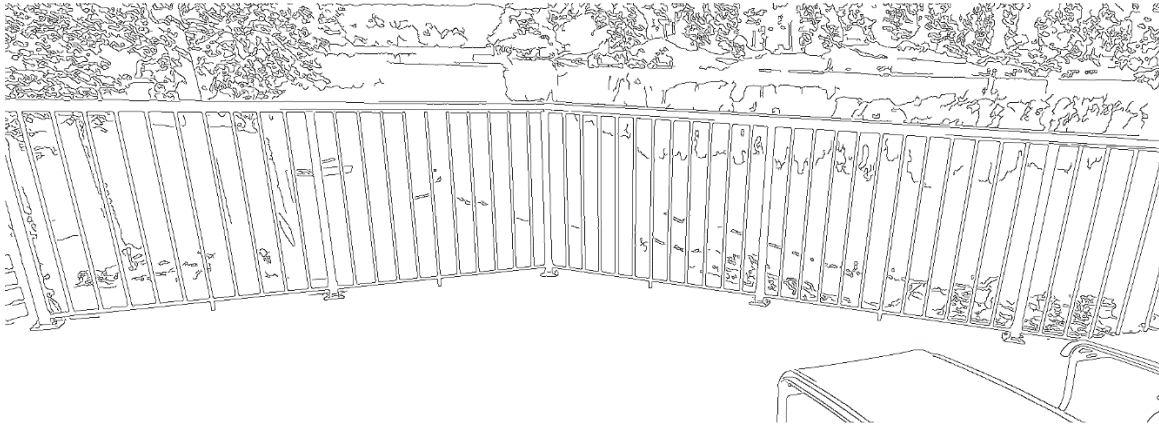

**Figure 114: Example of Protective Barrier with Large Elevation Change**

## Signage

Signage allows individuals decide whether the conditions are appropriate for their use and to familiarize themselves with expected features along the trail.

- Trailheads must include information on:
  - Length
  - Surface type
  - Width
  - Running and cross slopes
  - Location of amenities
  - Safety information

Signage must:

- Use high tonal contrast
- Use sans serif font
- Include tactile or cane detectable where appropriate
- Consider alternative formats (audio, digital applications) where possible

## Other Media, Audible Signage and Sensory Experiences

Where other media such as park websites or brochures are used to provide information about the recreational trail, beyond advertising, notice or promotion, provide the same information identified on the trailhead signage, with consideration for the use of smartphone, kiosk and tablet technology

- Equivalent content
- Braille, tactile maps, and audio options recommended
- Follow CNIB best practices for low-vision users



## B. Boardwalks

### Clear Width and Passing Areas

- Minimum clear width: 1000 mm
- Where boardwalk is less than 2000 mm wide, provide passing areas 1800 mm × 1800 mm at 30 m intervals

### Headroom

- Minimum clearance: 2100 mm, free of overhead hazards

## Surface Requirements

- Surfaces must be firm and stable
- Openings must be less than 20 mm, oriented perpendicular to direction of travel
- Must allow for drainage

## Slopes

- Preferred running slope: no greater than 1:20 (5%)
- Cross slope as gentle as possible, ensure stability and drainage
- Where slopes exceed these limits, apply Section 2.3 Ramps

## Edge Protection

Boardwalks must have edge protection that is at least 50 mm in height

# C. Beach Access Routes

## Entrances and Exits

- Provide a minimum clear opening of 1000 mm at all entrances, including those with gates, bollards or other entrance design
- Ensure entrances are maintained and clear of obstructions

## Clear Width and Headroom

- Minimum clear width: 1000 mm
- Minimum headroom clearance: 2100 mm
- Maintain routes free of obstacles and protrusions

## Surface Requirements

All beach access routes must have a surface that is firm and stable

## Constructed Surfaces

Where the surface is not natural (e.g., mats, modular systems, boardwalk-style platforms), the constructed surface must meet all of the following:

### Slopes

- Running slope: 1:10 (10%)
- Maximum cross slope: 1:50 (2%)

### Changes in Level

- Between 6–13 mm: must have a beveled edge at 1:2

- Between 14–200 mm: must have a maximum running slope of 1:10
- Over 200 mm: must meet full ramp requirements (Section 2.3 Ramps)

### Openings

- Must not permit the passage of an object >20 mm in diameter
- Elongated openings must be oriented perpendicular to the direction of travel

### Natural/Unconstructed Surfaces

Where the surface is natural (sand, compacted earth, native material):

- Maximum cross slope = minimum slope required for drainage
- Maximum running slope: 1:10

### Maintenance Requirements

To remain in compliance with IASR 80.10, beach access routes must be:

- Inspected at a frequency appropriate to season and usage
- Maintained free from sand accumulation, washouts, depressions, ponding, or hazards
- Restored to meet firm, stable, and slip-resistant conditions after storms or seasonal erosion
- Re-anchored, repaired, or replaced if mats or constructed surfaces shift, curl, or lift
- Monitored to ensure openings remain <20 mm and bevels remain intact

**Table 71A: Recreational Trails at a Glance**

| <b>Feature</b>           | <b>Minimum / Recommended Dimensions</b>   | <b>Notes / Key Requirements</b>   |
|--------------------------|---|---|
| <b>Entrances / Exits</b> | <ul style="list-style-type: none"> <li>• ≥1000 mm clear width</li> </ul>                        | <ul style="list-style-type: none"> <li>• Must remain clear</li> <li>• Gates/bollards cannot reduce width</li> </ul>         |
| <b>Trail Clear Width</b> | <ul style="list-style-type: none"> <li>• ≥1000 mm</li> </ul>                                    | <ul style="list-style-type: none"> <li>• Passing areas 1800 × 1800 mm at ≤30 m intervals where width &lt;1800 mm</li> </ul> |
| <b>Headroom</b>          | <ul style="list-style-type: none"> <li>• ≥2100 mm</li> </ul>                                    | <ul style="list-style-type: none"> <li>• Keep clear of branches, signs, or fixtures</li> </ul>                              |
| <b>Surface</b>           | <ul style="list-style-type: none"> <li>• Firm, stable</li> </ul>                                | <ul style="list-style-type: none"> <li>• Openings ≤20 mm; perpendicular orientation</li> </ul>                              |
| <b>Running Slope</b>     | <ul style="list-style-type: none"> <li>• ≤1:20 preferred</li> <li>• ≤1:10 acceptable</li> </ul> | <ul style="list-style-type: none"> <li>• &gt;10% requires AAC consultation</li> </ul>                                       |
| <b>Cross Slope</b>       | <ul style="list-style-type: none"> <li>• Gentle</li> </ul>                                      | <ul style="list-style-type: none"> <li>• Natural trails may vary based on terrain</li> </ul>                                |

| Feature                | Minimum / Recommended Dimensions  | Notes / Key Requirements  |
|------------------------|---|---|
|                        | <ul style="list-style-type: none"> <li>• Ensure drainage</li> </ul>                                 |   |
| <b>Edge Protection</b> | <ul style="list-style-type: none"> <li>• ≥50 mm</li> </ul>  | <ul style="list-style-type: none"> <li>• Not required where barrier or guardrail exists</li> </ul>                                    |
| <b>Signage</b>         | <ul style="list-style-type: none"> <li>• Trail length, surface, width, slopes, amenities</li> </ul> | <ul style="list-style-type: none"> <li>• High contrast</li> <li>• Sans serif</li> <li>• Tactile/digital options encouraged</li> </ul> |
| <b>Other Media</b>     | <ul style="list-style-type: none"> <li>• Equivalent to trailhead signage</li> </ul>                 | <ul style="list-style-type: none"> <li>• Audio / tactile maps recommended</li> </ul>  |

Table 71B: Boardwalks at a Glance

| Feature                | Minimum / Recommended Dimensions  | Notes / Key Requirements   |
|------------------------|---|--|
| <b>Clear Width</b>     | <ul style="list-style-type: none"> <li>• ≥1000 mm</li> </ul>              | <ul style="list-style-type: none"> <li>• Passing areas 1800 × 1800 mm at ≤30 m intervals if width &lt;2000 mm</li> </ul> |
| <b>Headroom</b>        | <ul style="list-style-type: none"> <li>• ≥2100 mm</li> </ul>              | <ul style="list-style-type: none"> <li>• No overhead hazards</li> </ul>  |
| <b>Surface</b>         | <ul style="list-style-type: none"> <li>• Firm, stable</li> </ul>          | <ul style="list-style-type: none"> <li>• Openings ≤20 mm</li> <li>• Perpendicular orientation</li> </ul>                 |
| <b>Running Slope</b>   | <ul style="list-style-type: none"> <li>• ≤1:20 preferred</li> </ul>       | <ul style="list-style-type: none"> <li>• If greater, follow Section 2.3 Ramps</li> </ul>                                 |
| <b>Cross Slope</b>     | <ul style="list-style-type: none"> <li>• As gentle as possible</li> </ul> | <ul style="list-style-type: none"> <li>• Must allow drainage</li> </ul>  |
| <b>Edge Protection</b> | <ul style="list-style-type: none"> <li>• ≥50 mm continuous</li> </ul>     | <ul style="list-style-type: none"> <li>• Required where boardwalk adjacent to drop-offs or water</li> </ul>              |

Table 71C: Boardwalks at a Glance

| Feature                  | Minimum / Required Dimensions  | Notes / Key Requirements  |
|--------------------------|--|---|
| <b>Entrances / Exits</b> | <ul style="list-style-type: none"> <li>• ≥1000 mm clear opening</li> </ul> | <ul style="list-style-type: none"> <li>• Applies even with gates, bollards, barriers</li> </ul> |
| <b>Clear Width</b>       | <ul style="list-style-type: none"> <li>• ≥1000 mm</li> </ul>               | <ul style="list-style-type: none"> <li>• Continuous width along full route</li> </ul>           |
| <b>Headroom</b>          | <ul style="list-style-type: none"> <li>• ≥2100 mm</li> </ul>               | <ul style="list-style-type: none"> <li>• Free of protrusions</li> </ul>                         |

| Feature                      | Minimum / Required Dimensions  | Notes / Key Requirements  |
|------------------------------|--|---|
| <b>Surface – General</b>     | <ul style="list-style-type: none"> <li>• Firm and stable</li> </ul>  | <ul style="list-style-type: none"> <li>• Applies to constructed and natural surfaces</li> </ul>   |
| <b>Surface – Constructed</b> | <ul style="list-style-type: none"> <li>• Cross slope <math>\leq 1:50</math> (2%)</li> <li>• Bevel 1:2 at 6–13 mm</li> <li>• Slope <math>\leq 1:10</math> at 14–200 mm</li> <li>• Ramp where <math>&gt;200</math> mm</li> </ul> | <ul style="list-style-type: none"> <li>• Must meet all IASR criteria</li> </ul>   |
| <b>Surface – Openings</b>    | <ul style="list-style-type: none"> <li>• <math>\leq 20</math> mm</li> </ul>  | <ul style="list-style-type: none"> <li>• Elongated openings must be perpendicular</li> </ul>  |
| <b>Surface – Natural</b>     | <ul style="list-style-type: none"> <li>• Cross slope = minimum for drainage</li> <li>• Running slope <math>\leq 1:10</math></li> </ul>   | <ul style="list-style-type: none"> <li>• Applies to sand / natural substrates</li> </ul>  |
| <b>Running Slope (all)</b>   | <ul style="list-style-type: none"> <li>• <math>\leq 1:10</math></li> </ul>   | <ul style="list-style-type: none"> <li>• Applies across all beach access types</li> </ul>   |
| <b>Maintenance</b>           | <ul style="list-style-type: none"> <li>• Ongoing inspection + remediation</li> </ul>   | <ul style="list-style-type: none"> <li>• Must remain firm, stable, level, unobstructed and compliant with slope and opening requirements</li> </ul> |

## 4.4 Curb Ramps and Depressed Curbs

### Curb Ramps

#### Rationale

Curb ramps enable individuals using mobility devices, vision aids, or other assistive devices to safely and independently transition between sidewalks, pedestrian routes, and roadways. Proper design ensures efficient pedestrian flow, safety, and orientation. Flared sides prevent hazards at edges, and tactile walking surface indicators alert individuals with vision loss to changes in level. Snow and ice accumulation must be cleared promptly to maintain accessibility.

#### Application

Applies to all curb ramps at:

- Pedestrian crossings
- Parking spaces and passenger loading zones
- Access aisles
- Other exterior routes with elevation changes

### Requirements

#### Surface & Alignment

- Stable, firm, slip-resistant, non-glare surfaces
- Align ramps with the direction of travel and opposite curb ramps for orientation and straight-line navigation

#### Width

- Signalized intersections: Minimum width of 3000 mm
- Non-signalized intersections: Minimum width of 2500 mm
- Standard ramp excluding flared sides: Minimum width of 1500 mm (Figure 33)
- Depressed curb configuration: Minimum width of 1220 mm at top of ramp

#### Slopes

- Running slope: 1:50–1:20 (2–5%)
  - If technically infeasible in a retrofit situation, max slope of 1:12 (8%) may be used
- Cross slope: Maximum of 1:50 (2%)
- Where curb ramps are designed with flared sides: slope between 1:15–1:10 (6.66–10%)

- Adjacent gutters and road surfaces: maximum 1:20 (5%)

### Tactile Walking Surface Indicators (TWSI)

- Location: bottom of ramp, 150–200 mm from curb edge
- Depth: 610 mm
- Full ramp width
- Strong colour contrast with ramp

### Flared Sides

- Minimum width: 1000 mm (Figure 35)
- Stable, slip-resistant, non-glare
- Clearly demarcated with grooves

### Drainage & Snow Management

- Provide suitable drainage to prevent water, ice and snow accumulation
- Designated snow piling areas located away from pedestrian routes

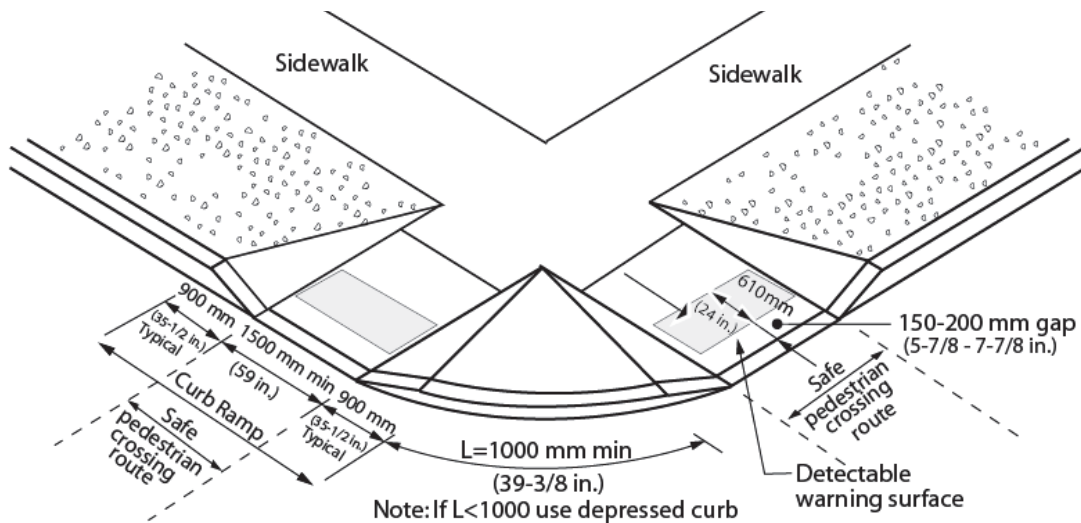

Figure 116: Standard Curb Ramp

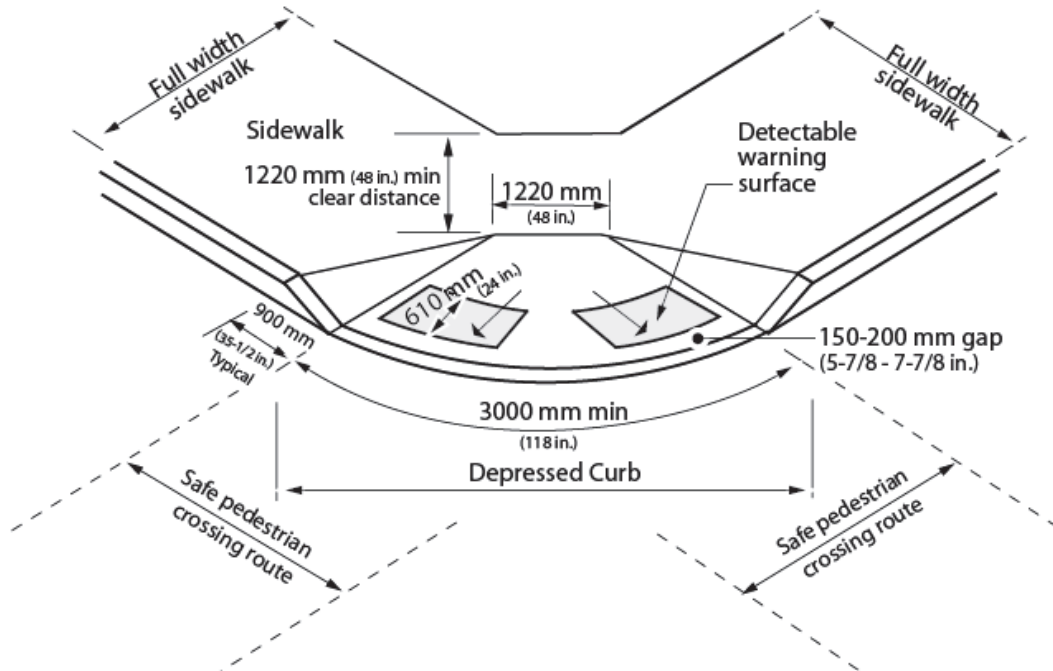

Figure 117: Alternate Curb Ramp

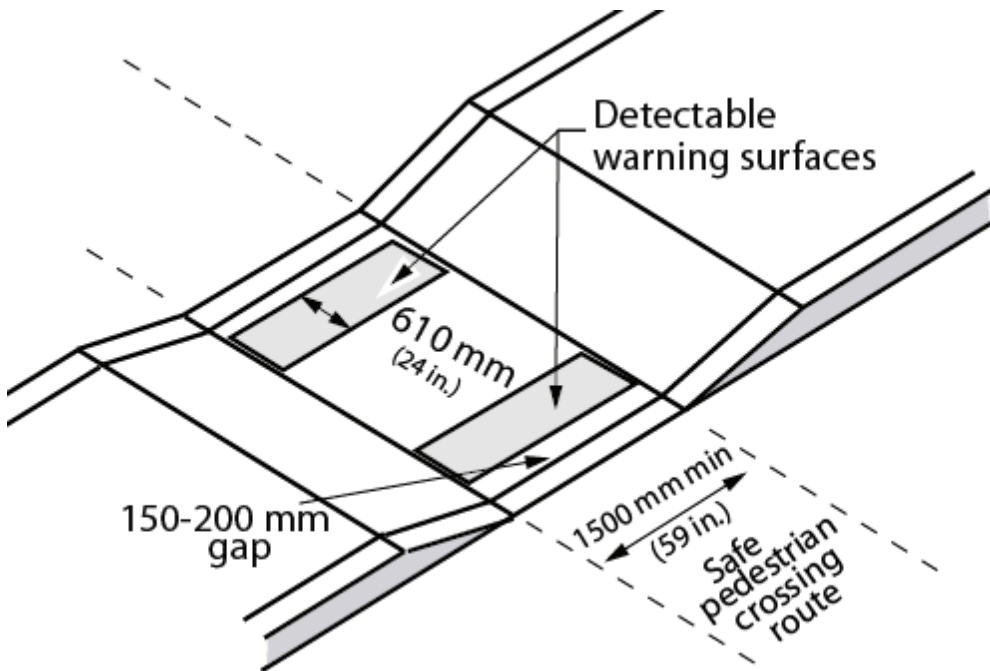

Figure 118: Curb Ramp at Narrow Median Sidewalk Crossing

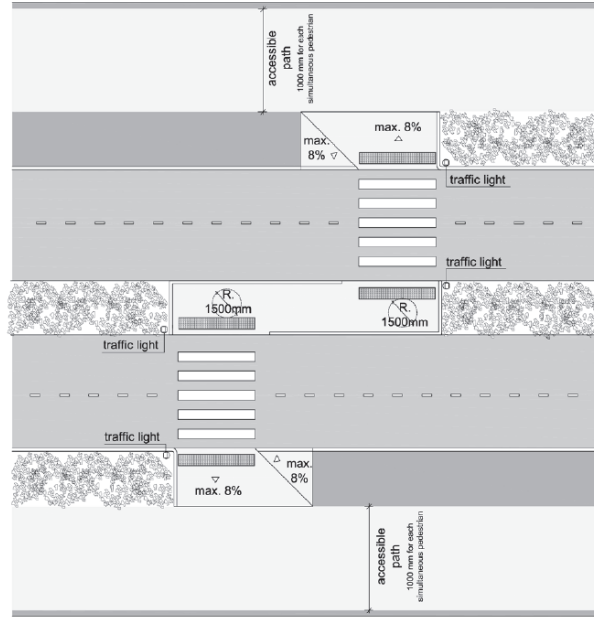

Figure 119: Curb Ramp at Offset Intermediate Island

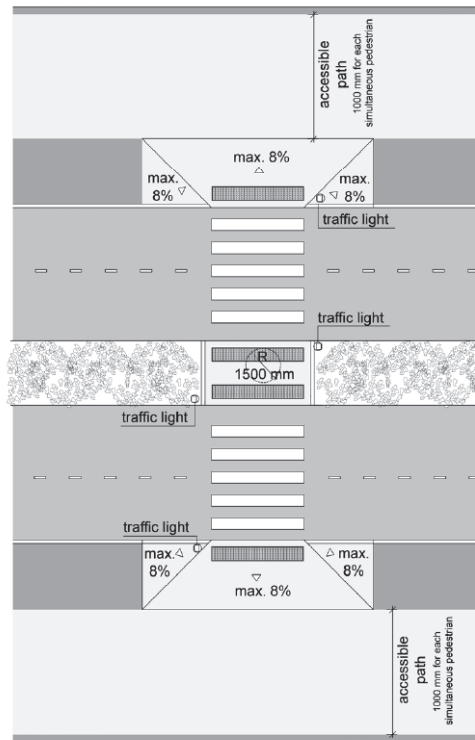
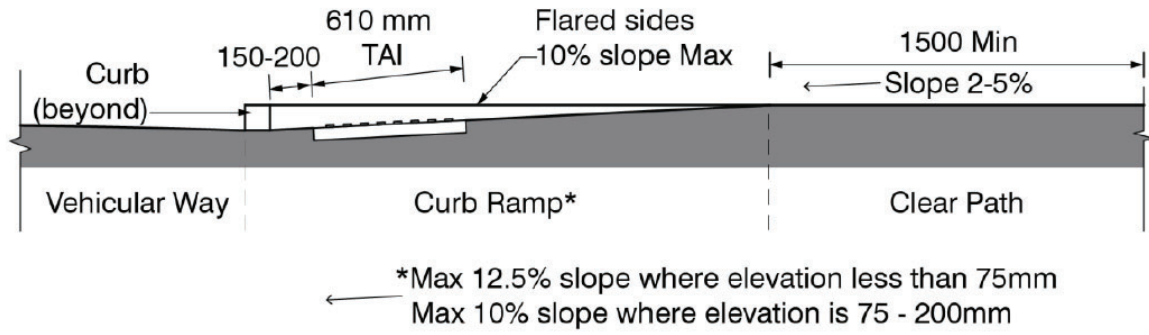
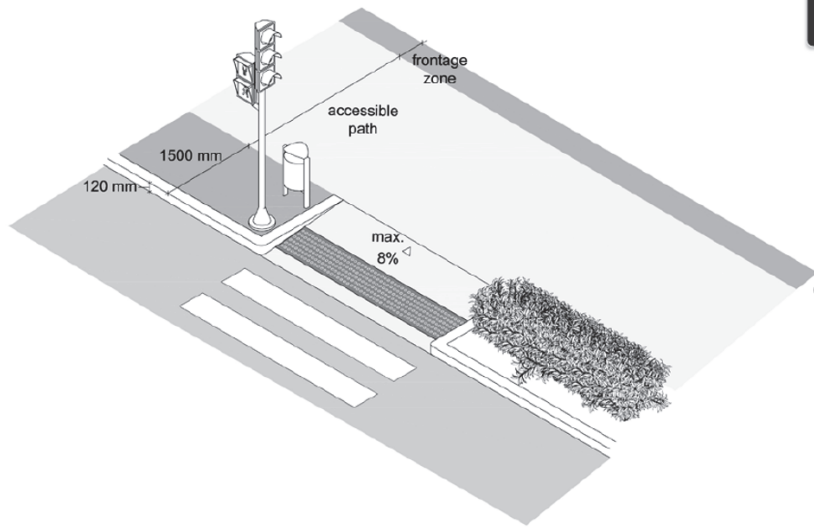

Figure 120: Aligned Intermediate Island



**Figure 121: Curb Ramp (Section)**



**Figure 122: Example of Returned Curb Cut**

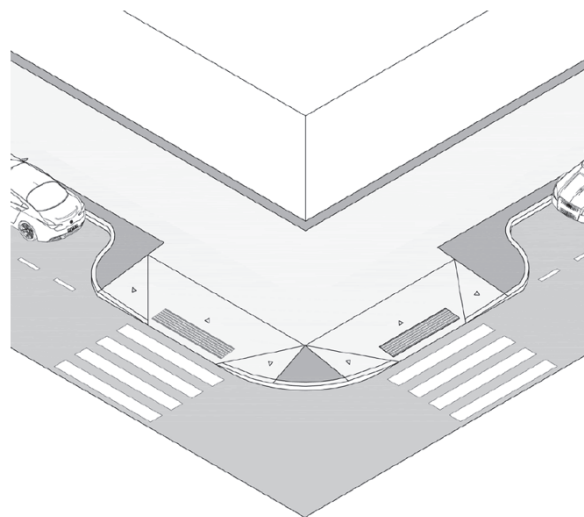

**Figure 123: Example of Curb Ramp Extensions**

## Depressed Curbs

### Rationale

Depressed curbs allow mobility device users and pedestrians to safely navigate grade transitions between sidewalks and roadways.

### Application

Applies to all depressed curbs at:

- Pedestrian crossings
- Parking spaces and passenger loading zones
- Access aisles
- Any exterior routes with elevation changes

### Design Requirements

#### Surface & Alignment

- Align with direction of travel
- Stable, firm, slip-resistant, non-glare surfaces

#### Width

- Signalized intersections: Minimum of 3000 mm
- Non-signalized intersections: Minimum of 2500 mm

#### Slopes

- Maximum running slope: 1:20 (5%)

#### Tactile Walking Surface Indicators (TWSI)

- Location: bottom of curb, 150–200 mm from back edge
- Depth: 610 mm
- Full width of curb
- Strong colour contrast

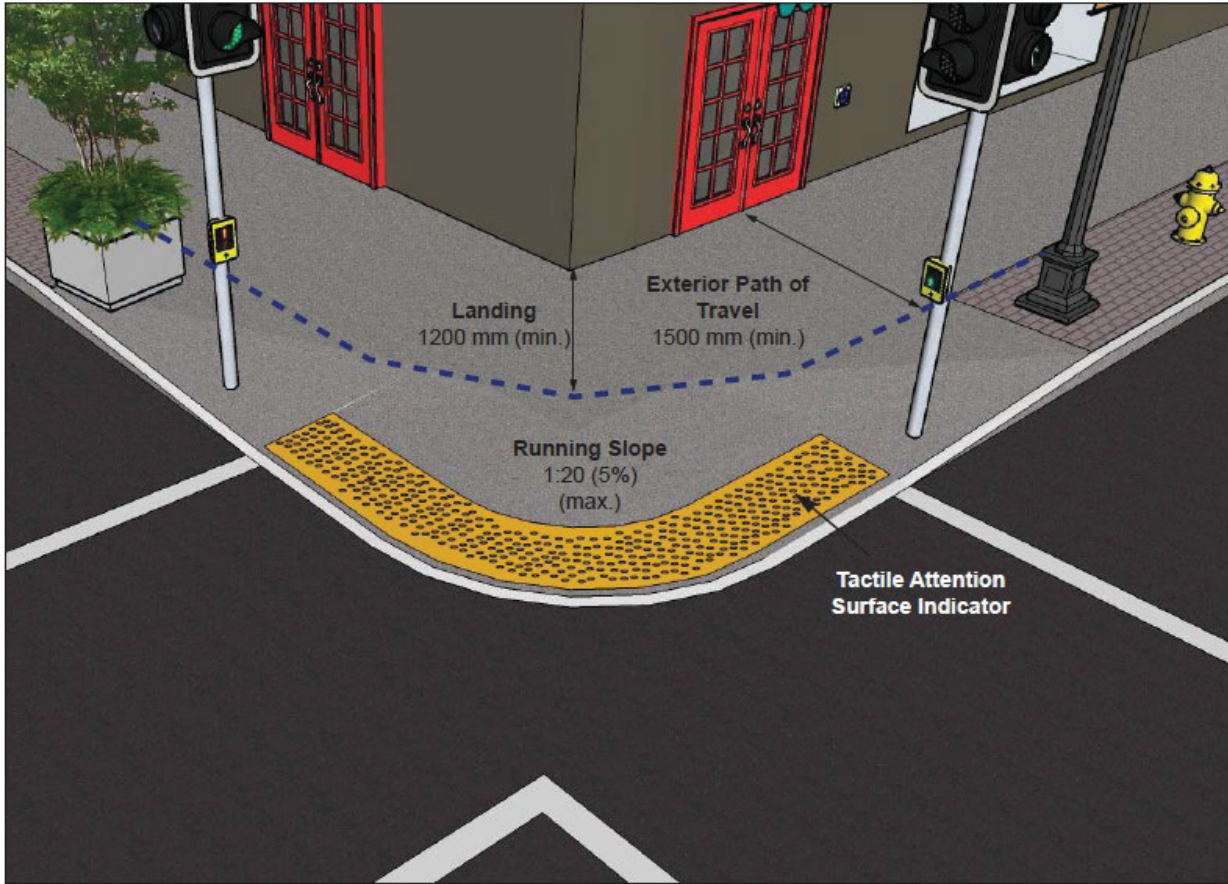

Figure 124: Typical Depressed Curb

**Guard Railings (where required)**

- Ensure inter-visibility for children, shorter adults and drivers
- Start at signal post without restricting push button access

Table 72: Curb Ramps and Depressed Curbs at a Glance

| Element            | Key Requirements  | Best Practices / Notes  |
|--------------------|---|---|
| <b>Curb Ramps</b>  |   |   |
| <b>Clear width</b> | <ul style="list-style-type: none"> <li>• Signalized: 3000 mm</li> <li>• Non-signalized: 2500 mm</li> <li>• Elsewhere: 1500 mm (excluding flared sides)</li> <li>• Depressed curb top: ≥1220 mm</li> </ul> | <ul style="list-style-type: none"> <li>• Stable, firm, slip-resistant, non-glare surface</li> <li>• Align with direction of travel</li> <li>• Provide drainage &amp; snow piling away from path</li> <li>• Consistent application at intersections and mid-block crossings</li> </ul> |

| Element  | Key Requirements   | Best Practices / Notes   |
|--|--|--|
| <b>Slopes</b>                                    | <ul style="list-style-type: none"> <li>• Running slope: 1:50–1:20 (2–5%)</li> <li>• Retrofit max 1:12 (8%)</li> <li>• Cross slope: ≤1:50 (2%)</li> </ul>                                       | <ul style="list-style-type: none"> <li>• Adjacent gutters/road surfaces: max 1:20 (5%)</li> </ul>  |
| <b>Flared sides</b>                              | <ul style="list-style-type: none"> <li>• Width: ≥1000 mm</li> <li>• Slope: 1:15–1:10 (6.66–10%)</li> </ul>   | <ul style="list-style-type: none"> <li>• Stable, slip-resistant, non-glare</li> <li>• Clearly demarcated with grooves</li> </ul>   |
| <b>Tactile Walking Surface Indicators (TWSI)</b> | <ul style="list-style-type: none"> <li>• Depth: 610 mm</li> <li>• Full ramp width</li> <li>• 150–200 mm setback from curb edge</li> </ul>  | <ul style="list-style-type: none"> <li>• Provide strong colour/tonal contrast</li> </ul>   |
| <b>Depressed Curbs</b>                           |  |  |
| <b>Clear width</b>                               | <ul style="list-style-type: none"> <li>• Signalized: 3000 mm</li> <li>• Non-signalized: 2500 mm</li> </ul>   | <ul style="list-style-type: none"> <li>• Same surface/consistency requirements as curb ramps</li> </ul>  |
| <b>Slopes</b>                                    | <ul style="list-style-type: none"> <li>• Max running slope: 1:20 (5%)</li> </ul>   | <ul style="list-style-type: none"> <li>• Align with direction of travel</li> <li>• Ensure drainage and snow/ice management</li> </ul>                                      |
| <b>Tactile Walking Surface Indicators (TWSI)</b> | <ul style="list-style-type: none"> <li>• Depth: 610 mm</li> <li>• Full curb width</li> <li>• 150–200 mm setback from back edge</li> </ul>  | <ul style="list-style-type: none"> <li>• Provide strong colour/tonal contrast</li> </ul>   |
| <b>Guard Railings (where required)</b>           | <ul style="list-style-type: none"> <li>• Provide inter-visibility between children, shorter adults, and drivers</li> <li>• Start at signal post without blocking push button access</li> </ul> | <ul style="list-style-type: none"> <li>• Use where high pedestrian traffic warrants added safety</li> <li>• Ensure design does not impede orientation or access</li> </ul> |

## 4.5 Pedestrian Crossings and Signals

### Rationale

Pedestrian crossings designate safe, accessible paths for all users. They combine visual, tactile, and auditory cues to guide and protect pedestrians, including individuals with mobility or vision limitations. Design features like raised crossings, APS, TWSIs, traffic islands, curb ramps, and depressed curbs create a seamless, safe crossing experience.

### Application

This section applies to all pedestrian crossings, including signalized, uncontrolled, and raised crossings, as well as intersections, mid-block areas, and pedestrian crossovers.

### Requirements

#### Design

- Surface: stable, firm, slip-resistant, non-glare, free of obstructions (gratings, access covers, gullies)
- Width: 2500–4000 mm to accommodate side-by-side mobility devices. Where possible, provide a minimum clear width of 3000 mm to accommodate multiple users and guide dog teams
- Pavement markings: must meet the criteria in [2240.033 Signalized Intersection Configurations of Pedestrian Crossings](#)
- Accessible pedestrian signals (APS): must be provided where signalized, meeting criteria in this section
- Dropped curbs and curb ramps: integrate with accessible paths and meet Section 4.4 Curb Ramps and Depressed Curbs
- Raised crossings: level with adjoining footways, full-width TWSIs, visual/tactile contrast, surface suitable for accessible vehicles

#### Controlled Crossings

- Where possible, provide adequate separation from side roads, driveways and bus stops to maintain pedestrian-vehicle visibility
- APS installed per this section, including tactile, auditory and vibro-tactile features
- Meet the criteria in [2240.033 Signalized Intersection Configurations of Pedestrian Crossings](#)

## Uncontrolled Crossings

- Connect walkways along accessible routes
- Where possible, include traffic islands for temporary refuge and safety
- Consider staggered island layouts
- Meet the criteria in [2240.034 Controlled Non-Signalized Intersection Configurations of Pedestrian Crossings](#)

## Raised Pedestrian Crossings

- Provide level access across the roadway, eliminating the need for curb ramps
- Continuous raised area, flush with pathways
- TWSIs across entry points
- Visual and tactile contrast on edges
- Surface must not obstruct accessible buses

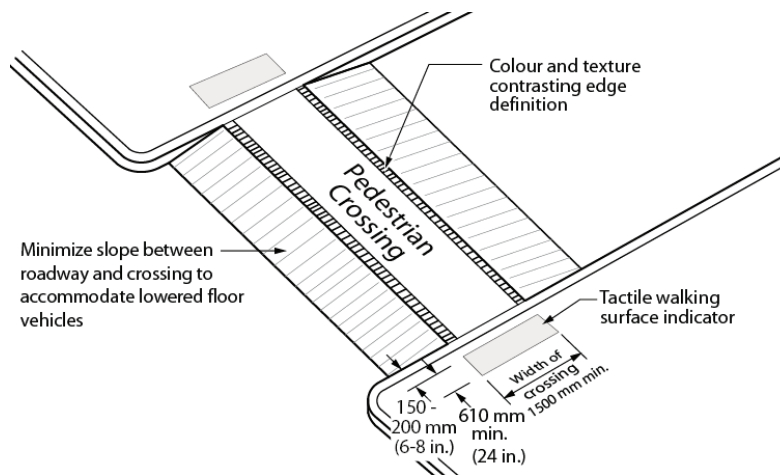

Figure 125: Raised pedestrian crossing

## Accessible Pedestrian Signals

- Distinct locator tone separate from walk signal
- Mounted at a maximum of 1100 mm high
- Installed within 1500 mm of the edge of the curb
- Tactile arrows aligned with crossing direction
- Support both manual and automatic activation, providing audible & vibro-tactile feedback
- Signal volume adjustable or auto-adaptive to ambient noise
- Minimum 3000 mm separation between APS devices at same corner

- If not feasible, install on single post with verbal announcements clearly stating which crossing is active
- Ensure each push button is on the side of the post facing the pedestrian waiting area
- Align the face of each unit to be parallel to the associated crosswalk
- Adjust crossing times to accommodate slower users
- APS should be installed on a stable, level surface clear of obstructions

## Traffic Islands

- Clear width of 1800 mm minimum, where possible
- Include TWSIs and colour/brightness contrast
- Dropped curbs to integrate with approach pathways per Sections 4.4 Curb Ramps and Depressed Curbs
- Staggered islands preferred for longer crossings
- Guard rails optional where necessary for pedestrian safety

**Table 73: Pedestrian Crossings and Signals at a Glance**

| Element                               | Key Requirements  | Best Practices / Notes  |
|---------------------------------------|---|---|
| <b>Pedestrian Crossings (General)</b> | <ul style="list-style-type: none"> <li>• Width: 2500–4000 mm (3000 mm preferred)</li> <li>• Stable, firm, slip-resistant, non-glare surface</li> <li>• Free of obstacles (gratings, covers, gullies)</li> <li>• Pavement markings per municipal/TAC standards</li> </ul>                    | <ul style="list-style-type: none"> <li>• Raised crossings where feasible for level access</li> <li>• Provide visual and tactile contrast at edges</li> <li>• Continuous TWSIs across crossing entry points</li> </ul> |
| <b>Controlled Crossings</b>           | <ul style="list-style-type: none"> <li>• Located away from side roads, driveways, and bus stops for clear sightlines</li> <li>• Include APS per Section 4.5 Accessible Pedestrian Signals</li> <li>• Dropped curbs and curb ramps per Section 4.4 Curb Ramps and Depressed Curbs</li> </ul> | <ul style="list-style-type: none"> <li>• Include countdown signals at intersections</li> <li>• Ensure crossing time accommodates slower pedestrians</li> </ul>  |
| <b>Uncontrolled Crossings</b>         | <ul style="list-style-type: none"> <li>• Connect accessible routes</li> <li>• Include traffic islands for refuge where possible</li> </ul>  | <ul style="list-style-type: none"> <li>• Staggered islands provide added waiting space</li> </ul>   |

| Element                                    | Key Requirements  | Best Practices / Notes  |
|--|---|---|
|  | <ul style="list-style-type: none"> <li>• Meet local safety and TAC guidelines</li> </ul>  | <ul style="list-style-type: none"> <li>• Avoid direct alignment where children or mobility-limited pedestrians cross alone</li> </ul>   |
| <b>Raised Pedestrian Crossings</b>         | <ul style="list-style-type: none"> <li>• Continuous raised area flush with sidewalks</li> <li>• Full-width TWSIs at entry points</li> <li>• Visual and tactile edge contrast</li> <li>• Surface suitable for accessible vehicles</li> </ul>   | <ul style="list-style-type: none"> <li>• Acts as traffic calming</li> <li>• Eliminates need for curb ramps</li> <li>• Ensure proper drainage and slip resistance</li> </ul>   |
| <b>Accessible Pedestrian Signals (APS)</b> | <ul style="list-style-type: none"> <li>• Distinct locator tone (different from walk tone)</li> <li>• Mount <math>\leq 1100</math> mm high, <math>\leq 1500</math> mm from curb edge</li> <li>• Tactile arrow aligned with crossing direction</li> <li>• Manual or automatic activation with audible and vibro-tactile feedback</li> <li>• Minimum 3000 mm between devices at same corner or single post with clear verbal identification</li> </ul> | <ul style="list-style-type: none"> <li>• Volume adaptive to ambient noise</li> <li>• Align APS toward pedestrian waiting area</li> <li>• Allow sufficient crossing time for all users</li> </ul>                            |
| <b>Traffic Islands</b>                     | <ul style="list-style-type: none"> <li>• Clear width <math>\geq 1800</math> mm where feasible</li> <li>• Include TWSIs and colour/brightness contrast</li> <li>• Dropped curbs per Section 4.4 Curb Ramps and Depressed Curbs</li> </ul>  | <ul style="list-style-type: none"> <li>• Staggered placement preferred for safety</li> <li>• Guard rails optional where required for protection</li> <li>• Use materials distinguishable from surrounding paving</li> </ul> |

## 4.6 Pedestrian Bridges and Underpasses

### Rationale

Pedestrian bridges and underpasses are an extension of exterior paths of travel and provide a dedicated, accessible route above or below vehicle traffic, railways, or natural barriers. These structures help ensure a continuous, safe path for pedestrians, including individuals using mobility devices, people with vision impairments, and others who need barrier-free access.

### Application

This section applies to pedestrian bridges and underpasses that allow for a continuous, unobstructed route for pedestrians that is separate from vehicle traffic.

### Requirements

#### Design

In addition to the requirements in Section 4.3 Accessible Paths of Travel pedestrian bridges and underpasses must:

- Have ramp running slopes that are 1:20 (5%) preferred and 1:15 (6.67%) maximum
- Have landing cross slopes of 1:50 (2%) maximum
- Have switch-back landings with a turning radius of 2350 mm minimum
- Clearway between handrails of 3000 mm minimum
- Maintain overhead clearance on ramps and decks of 2700 mm minimum
- Use non-slip surfacing for ramps, steps and bridges with suitable colour-contrasting handrails and/or guards
- Meet lighting requirements in Section 5.8 Lighting
- Minimize environmental impacts by using raised boardwalks or lightweight structures where feasible, in accordance with the Mississauga Zoning ByLaw
- Conform signage and wayfinding to Section 5.9 Signage and Wayfinding

#### Location and Access

- Site selection should minimize the need for steps by considering natural topography
- Provide lifts or alternative accessible devices where ramps are not feasible

## Approach

- Signage to identify and support orientation to the bridge or underpass
- Provide adequate drainage to prevent water accumulation or slippery surfaces
- Locate ramps and stairs as close as possible to each other where both are provided

## Additional Best Practices Notes:

- Include tactile surfaces and edge markings on landings and bridge edges
- Incorporate integrated handrail designs for both sides of ramps
- Consider lighting that highlights both the travel surface and any hazards
- Include emergency access points if structure is long or enclosed
- Ensure bridge/underpass connections align with pedestrian desire lines and adjacent accessible paths

**Table 74: Pedestrian Bridges and Underpasses at a Glance**

| Feature                                   | Requirement / Recommended  | Notes / References  |
|---|--|---|
| <b>Ramp Running Slope</b>                 | <ul style="list-style-type: none"> <li>• 1:20 (5%) preferred</li> <li>• 1:15 (6.7%) maximum</li> </ul>     | <ul style="list-style-type: none"> <li>• Default and maximum slope per Mississauga design standards</li> </ul>                  |
| <b>Landing Cross Slope</b>                | <ul style="list-style-type: none"> <li>• Maximum 1:50 (2%)</li> </ul>                                      | <ul style="list-style-type: none"> <li>• Ensures safe, level landings for rest and stability</li> </ul>                         |
| <b>Switch-Back Landing Turning Radius</b> | <ul style="list-style-type: none"> <li>• Minimum 2350 mm</li> </ul>  | <ul style="list-style-type: none"> <li>• Allows wheelchair and mobility device turning</li> </ul>                               |
| <b>Clearway Between Handrails</b>         | <ul style="list-style-type: none"> <li>• Minimum 3000 mm</li> </ul>  | <ul style="list-style-type: none"> <li>• Continuous, unobstructed route across ramps</li> </ul>                                 |
| <b>Overhead Clearance (Ramps / Decks)</b> | <ul style="list-style-type: none"> <li>• Minimum 2700 mm</li> </ul>  | <ul style="list-style-type: none"> <li>• Provides safe vertical clearance for all users</li> </ul>                              |
| <b>Handrails / Guards</b>                 | <ul style="list-style-type: none"> <li>• Colour-contrasting, non-slip, continuous on both sides</li> </ul> | <ul style="list-style-type: none"> <li>• Include tactile and visual cues</li> <li>• Align with Section 2.5 Handrails</li> </ul> |
| <b>Surfacing</b>                          | <ul style="list-style-type: none"> <li>• Non-slip, stable, firm, non-glare</li> </ul>                      | <ul style="list-style-type: none"> <li>• Applies to ramps, steps, and</li> </ul>  |

| Feature                          | Requirement / Recommended   | Notes / References   |
|----------------------------------|---|--|
|                                  |   | bridge decks   |
| <b>Lighting</b>                  | <ul style="list-style-type: none"> <li>• Meets Section 5.8 Lighting</li> </ul>                                      | <ul style="list-style-type: none"> <li>• Illuminate both surfaces and potential hazards</li> </ul>         |
| <b>Environmental Integration</b> | <ul style="list-style-type: none"> <li>• Raised boardwalks or low-impact supports where feasible</li> </ul>         | <ul style="list-style-type: none"> <li>• Minimize disturbance per Mississauga Zoning By-law</li> </ul>     |
| <b>Signage / Wayfinding</b>      | <ul style="list-style-type: none"> <li>• Conforms to Section 5.9 Signage and Wayfinding</li> </ul>                  | <ul style="list-style-type: none"> <li>• Include visible directional and identification signage</li> </ul> |
| <b>Alternative Access</b>        | <ul style="list-style-type: none"> <li>• Provide lifts or elevating devices where ramps not feasible</li> </ul>     | <ul style="list-style-type: none"> <li>• For persons unable to use stairs</li> </ul>                       |
| <b>Approach</b>                  | <ul style="list-style-type: none"> <li>• Visible signage and adequate drainage</li> </ul>                           | <ul style="list-style-type: none"> <li>• Connects to exterior accessible path of travel</li> </ul>         |
| <b>Tactile / Edge Cues</b>       | <ul style="list-style-type: none"> <li>• Tactile walking surfaces and edge markings recommended</li> </ul>          | <ul style="list-style-type: none"> <li>• Especially on long bridges or enclosed underpasses</li> </ul>     |
| <b>Emergency Access</b>          | <ul style="list-style-type: none"> <li>• Provide emergency access points for long or enclosed structures</li> </ul> | <ul style="list-style-type: none"> <li>• Recommended for safety and maintenance access</li> </ul>          |

## 4.7 Street Furniture

### Rationale

Street furniture and elements support safe, accessible, and inclusive outdoor spaces. All furniture must integrate into exterior accessible paths of travel without creating obstacles. Visual contrast and tactile cues enhance usability for people with low vision or other impairments.

### Application

This section applies to all exterior site furniture and elements located along or adjacent to exterior accessible paths of travel, including:

- Benches and seating areas
- Waste and recycling bins
- Bollards and post barriers
- Drinking fountains and water stations
- Bicycle racks and storage fixtures

### Requirements

#### General Features

- Street furniture must not reduce the minimum width of accessible paths
- Eating area furniture (tables and chairs) must be positioned or contained to prevent movement into pedestrian clearways
- Furniture should be aligned in a predictable arrangement with equal spacing between items
- Furniture must be usable without moving or removing it
- Leading edges must be cane detectable with a maximum height of 680 mm
- Edges must be rounded to avoid injury
- Controls or operating mechanisms must be mounted at a maximum height of 1060 mm
- Colour and tonal contrast must be at least 70% from surroundings
- Bollards, waste receptacles, recycling bins and unexpected fixtures must have visual

contrasting bands

- Tall fixtures must have two high-visibility contrast bands at a seated height of 1150 mm and standing height of 1800 mm
- Drinking fountains and water bottle filling stations must be accessible but not obstruct paths
- Bicycle racks and storage must be connected to, but outside of, the exterior accessible path of travel

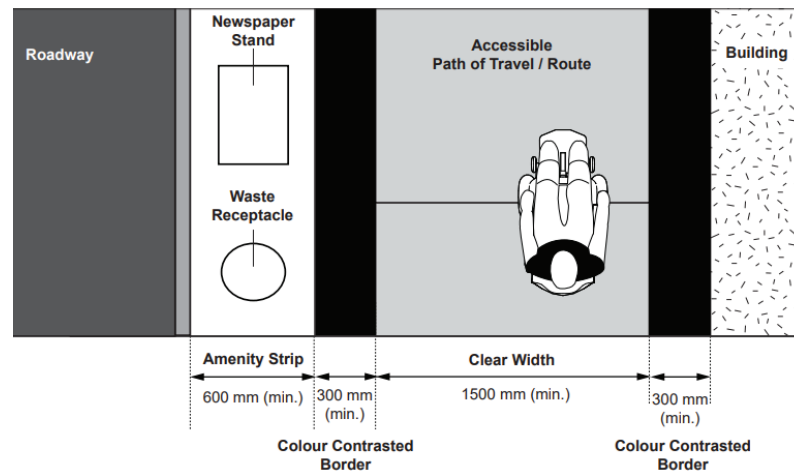

**Figure 126: Typical Amenity Strip for Street Furniture Placement**

## Benches and Seats

Benches and seats in exterior environments must comply with the dimensional and functional requirements set out in Section 2.11 Seating, Tables and Work Surfaces. In addition, the following outdoor considerations apply:

- Benches must be adjacent to an accessible path of travel, without obstructing pedestrian clearways
- Provide a firm, level and stable surface of at least 920 mm by 1370 mm for approach and transfer
- Ensure benches are stable and securely fixed to avoid tipping or shifting
- Incorporate a minimum 70% colour or tonal contrast between the bench and adjacent ground surface
- Provide a variety of seating types to meet different needs; at least 20% of benches should omit armrests to allow lateral wheelchair transfer
- For benches with armrests, locate at least one armrest between 220 mm and 300 mm

above the seat and set back no more than 75 mm from the front edge

- Where possible, incorporate a 150 mm setback beneath the seat to assist with standing
- Position benches to provide clear sightlines and to avoid conflicts with the other street furniture, landscaping or pedestrian flow

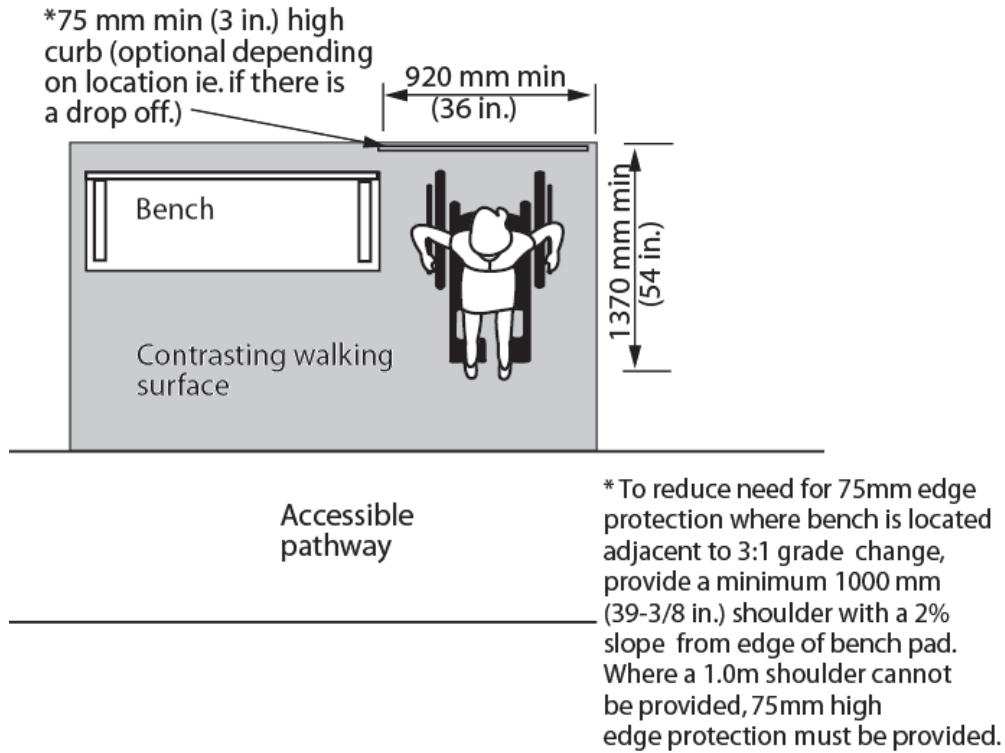

Figure 127: Rest Area

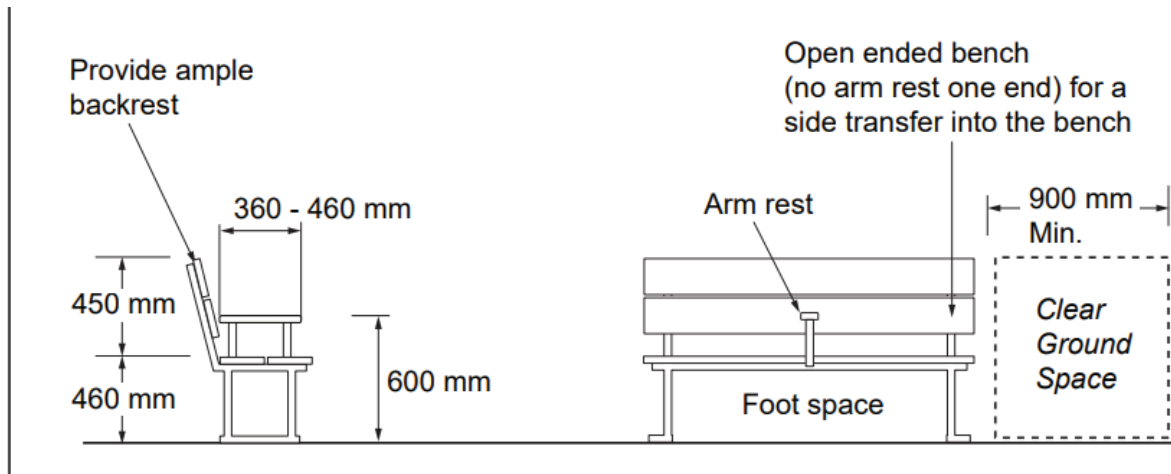
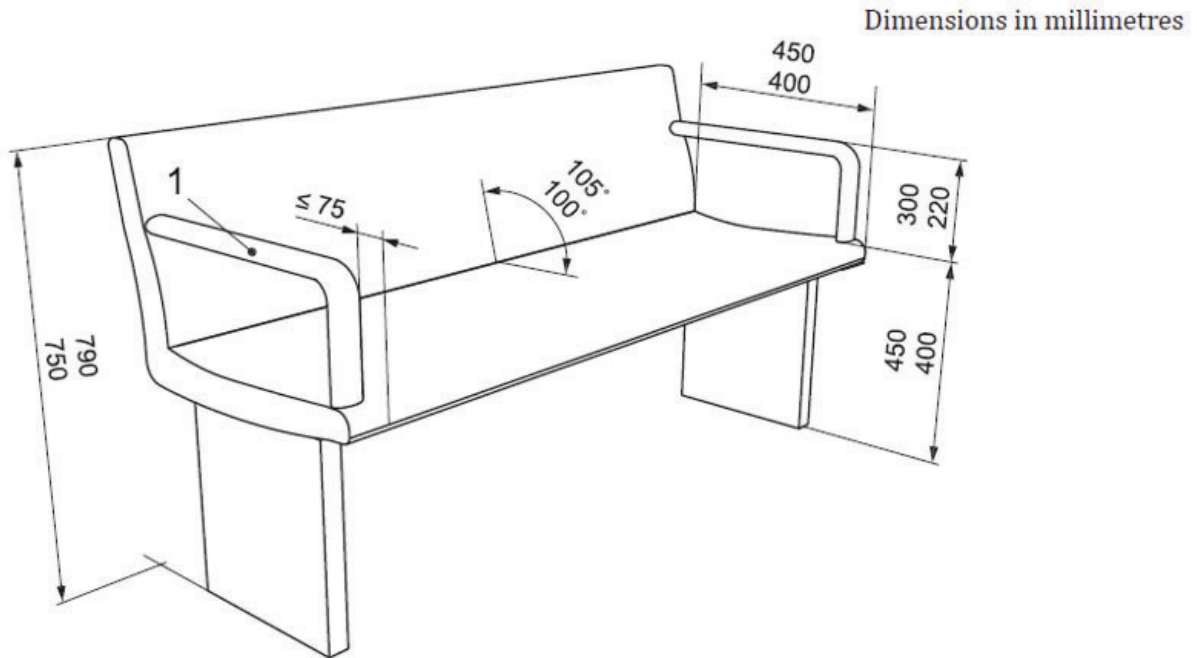

Figure 127: Example of a Bench with Middle Armrests and Back Support



### Key

1. Armrests to be omitted on some benches to allow lateral transfer from wheelchairs

**Figure 128: Example of a Bench with Armrests and Back Support**

## Waste Receptacles and Recycling Bins

Waste receptacles and recycling bins should be connected to an exterior accessible path of travel or pedestrian clearway. Controls and operating mechanisms, such as lids and openings, should be provided and have space and reach ranges. The placement of openings should be designed with consideration for persons with low to no vision. Opening should be placed in the same order wherever they are located. For example, the left-side opening should be waste and the right-side opening should be recycling.

- Must be on level, firm, stable, slip-resistant surfaces
- Must have self-closing lids
- Openings must:
  - Face an exterior accessible path of travel
  - Be distinguishable in shape and colour
  - Be mounted between 900 mm and 1100 mm
  - Be operable using a closed fist

- Must have colour and brightness contrast from surroundings
- Must be cane detectable
- Must be large enough to prevent overflow and tripping hazards
- Must be clearly identified with lettering compliant with Section 5.9 Signage and Wayfinding

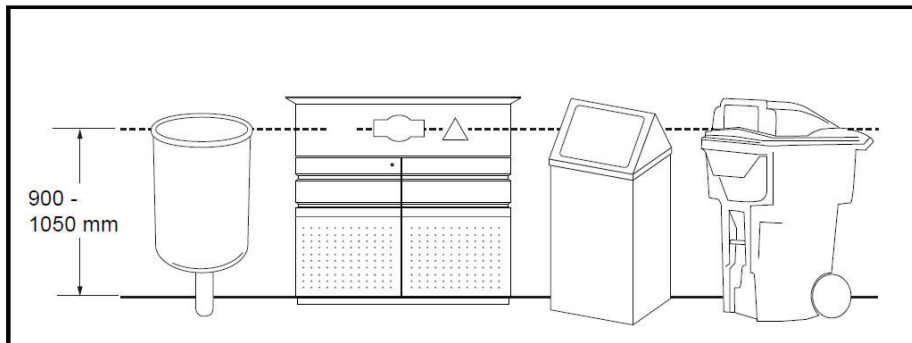

**Figure 129: Example of a Waste Receptacles and Recycling Bins**

## Bollards

- Where possible, should be installed where:
  - A curb does not separate accessible route and access aisle
  - Off-street parking has depressed curbs
- Installation must not reduce clear width requirements (850 mm at entrances, 1500 mm on exterior paths)
- Must be a minimum height of 800 mm
- Must be cane detectable
- Must have visual contrast markings near the top
- Must be placed in line, equally spaced to allow pedestrian passage, including mobility device users
- Must have consistent profile from ground to top
- Must not be linked with ropes or chains
- Flexible bollards that return upright after collisions should be considered near pedestrian crossings

Table 75: Street Furniture at a Glance

| Element                                   | Key Requirements / Dimensions   | Notes / References  |
|---|---|---|
| <b>General Furniture</b>                  | <ul style="list-style-type: none"> <li>• Must not reduce clear width of accessible path (850 mm at entrances, 1500 mm on exterior paths)</li> <li>• Leading edge cane detectable, max 680 mm high</li> <li>• Rounded edges • Controls ≤ 1060 mm</li> <li>• Colour/tonal contrast ≥ 70%</li> <li>• Tall fixtures: two contrast bands (1150 mm seated, 1800 mm standing)</li> </ul>   | <ul style="list-style-type: none"> <li>• See Sections 4.2 Accessible Paths of Travel and 5.1 Controls and Operating Mechanisms</li> </ul> |
| <b>Benches &amp; Seats</b>                | <ul style="list-style-type: none"> <li>• Adjacent to accessible path</li> <li>• Firm, level, stable approach surface 920 × 1370 mm</li> <li>• Seat height 450–500 mm, depth 450–510 mm</li> <li>• Under-seat setback 150 mm (min.)</li> <li>• Back support 450 mm above seat (5–15° angle)</li> <li>• Armrests 220–300 mm above seat; omit on 20% of benches for lateral transfer</li> <li>• ≥ 70% colour/tonal contrast</li> </ul> | <ul style="list-style-type: none"> <li>• See Section 2.11 Seating, Tables and Work Surfaces and Figures 25–27</li> </ul>                  |
| <b>Waste Receptacles / Recycling Bins</b> | <ul style="list-style-type: none"> <li>• Firm, stable, slip-resistant surface</li> <li>• Self-closing lids</li> <li>• Openings 900–1100 mm high, operable with closed fist</li> <li>• Openings face accessible path, consistent left/right layout</li> <li>• Colour/shape distinction, cane detectable</li> <li>• Clear labeling per signage standards</li> </ul>   | <ul style="list-style-type: none"> <li>• See Sections 5.1 Controls and Operating Mechanisms and 5.9 Signage and Wayfinding</li> </ul>     |
| <b>Bollards</b>                           | <ul style="list-style-type: none"> <li>• Min height 800 mm</li> <li>• Cane detectable</li> <li>• High-contrast markings near top</li> <li>• Even spacing – aligned and unlinked (no chains/ropes)</li> </ul>  | <ul style="list-style-type: none"> <li>• See Figures 29–30 and Section 4.2 Accessible Paths of Travel</li> </ul>                          |

| Element   | Key Requirements / Dimensions   | Notes / References   |
|---|---|--|
|   | <ul style="list-style-type: none"> <li>• Must not reduce clear width</li> <li>• Flexible bollards recommended near crossings</li> </ul>   |  |
| <p style="text-align: center;"><b>Drinking Fountains / Water Stations</b></p> | <ul style="list-style-type: none"> <li>• Connected to accessible path but outside clearway</li> <li>• Controls ≤ 1060 mm high</li> <li>• Colour/tonal contrast ≥ 70%</li> </ul> | <ul style="list-style-type: none"> <li>• See Sections 4.2 and 5.1</li> </ul>   |
| <p style="text-align: center;"><b>Bike Racks / Locking Posts</b></p>          | <ul style="list-style-type: none"> <li>• Connected to accessible path but outside travel path</li> <li>• Provide accessible reach and clear ground space</li> </ul>             | <ul style="list-style-type: none"> <li>• See Active Transportation Design Guidelines (Reference Doc XXXX)</li> </ul> |

## 5.1 Controls and Operating Mechanisms

### Rationale

Controls and operating mechanisms—such as switches, buttons, touchscreens, intercoms, and ICT interfaces—must be designed to be independently usable by all individuals, including those with limited mobility, vision, dexterity, or cognitive ability. These elements are critical for enabling access to public information, services, and spaces.

Designing for appropriate reach, low operating force, clear floor space and multi-sensory feedback ensures equitable access to information, services and spaces.

### Application

This section applies to all publicly accessible controls and operating mechanisms, including:

- Light switches, thermostats, and fire alarm pulls
- Intercoms, card readers and security systems
- Self-service kiosks, vending and ticketing machines, payment terminals and ICT touchpoints
- Public information systems and interactive displays

Controls may be located indoors or outdoors and must be reachable from accessible routes.

### Design Requirements

#### Operability

- Controls must be operable with one hand without tight grasping, pinching, or twisting of the wrist
- Maximum operating force: 22 Newtons for user controls, including manual pull stations and typical pushbuttons
- Push-button surfaces must be:
  - Minimum 13 mm diameter and not recessed for general controls
  - Minimum 19 mm for elevator hall and cab buttons where provided

#### Clear floor space and reach

- Front approach: Clear floor space of 900 mm by 1500 mm
- Side Approach: Clear floor space of 900 mm x 2200 mm

- General reach band to operable portions is 460 to 1050 mm A.F.F.
  - Where an obstruction exists, maintain:
    - 600 mm touch reach
    - 500 mm grasp reach

### **Mounting heights**

- Mount general controls 900 mm to 1200 mm A.F.F.
- Mount thermostats and fire alarm pulls 1200 mm A.F.F. to centreline
- Keep outlets at a minimum height of 400 mm and within forward/side reach bands

### **Visual, tactile and audible Feedback**

- Provide colour or tonal contrast between controls and adjacent surfaces with a target of at least 70% luminance contrast where feasible
- Provide raised symbols or tactile indicators where needed to identify function
- Provide audible and/or visual signals that confirm activation (where applicable)

### **ICT and Self-Service Devices**

- Devices must support multimodal interaction: tactile, visual, audible and optional haptic feedback
- Screens must be mounted between 1200 mm and 1500 mm from the floor and meet the space and reach requirements listed in this section and Section 2.1 Space and Reach Requirements
- Where possible, mitigate glare with matte finished and orientation that avoids direct light sources; use anti-glare coatings where needed
- Provide alternative formats such as large text, Braille/tactile labelling for key controls, audio output, captions for audio-visual media and sign language
- Where feasible, provide a headphone jack and volume control with clear on-screen or tactile labelling where audio is used

### **Security and Access Systems**

- Card readers and intercoms must be mounted at 900 mm to 1100 mm A.F.F. and outside door swing arcs with 600-1500 mm lateral clearance
- Controls must be synchronized with power door operators
- Provide both audible and visual indicators for access confirmation

### **Environmental and placement considerations**

- Ensure controls are located on or adjacent to accessible routes without creating protruding-object hazards

- For outdoor controls, ensure weather protection, non-glare finishes, and reliable winter operation
- Align multiple controls along a consistent height where feasible to aid predictability

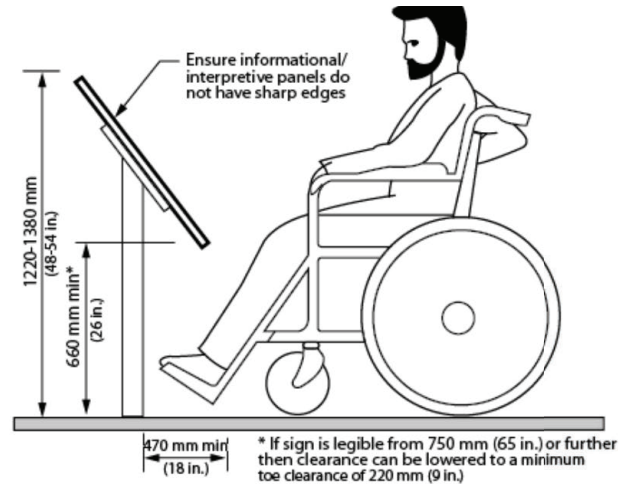

**Figure 4.4.10.1** Critical Dimensions for Information Systems and Displays

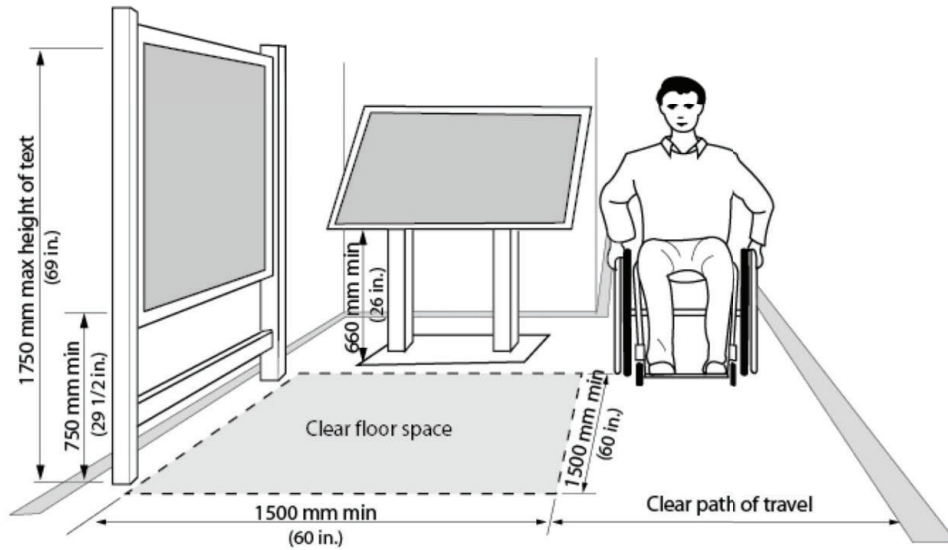

**Figure 4.4.10.2** Clear Space and Dimensions around Information Systems

**Figure 130: Clear Space and Dimensions Around Information Systems**

Table 76: Controls and Operating Mechanisms – At a Glance

| Element                                    | Key Requirements / Dimensions   | Notes / References  |
|--|---|---|
| <b>Operability</b>                         | <ul style="list-style-type: none"> <li>• Operable with one hand without tight grasping, pinching or twisting</li> <li>• Max operating force 22 N</li> <li>• Push-button surface <math>\geq 13</math> mm (<math>\geq 19</math> mm for elevator buttons)</li> </ul> | <ul style="list-style-type: none"> <li>• Ensure independent operation</li> <li>• Avoid foot-operated controls</li> </ul>                            |
| <b>Clear Floor Space and Approach</b>      | <ul style="list-style-type: none"> <li>• Front approach 900 × 1500 mm</li> <li>• Side approach 900 × 2200 mm</li> <li>• Unobstructed and firm surface</li> </ul>  | <ul style="list-style-type: none"> <li>• May overlap accessible routes</li> <li>• See Section 2.1 Space and Reach Requirements</li> </ul>           |
| <b>Reach Ranges / Bands</b>                | <ul style="list-style-type: none"> <li>• General reach 460–1050 mm A.F.F.</li> <li>• Where obstruction exists touch reach <math>\leq 600</math> mm, grasp reach <math>\leq 500</math> mm</li> </ul>   | <ul style="list-style-type: none"> <li>• Maintain consistent height along walls</li> </ul>  |
| <b>Mounting Heights</b>                    | <ul style="list-style-type: none"> <li>• General controls 900–1200 mm A.F.F.</li> <li>• Thermostats and fire alarm pulls 1200 mm centreline</li> <li>• Outlets <math>\geq 400</math> mm A.F.F.</li> </ul>   | <ul style="list-style-type: none"> <li>• Within forward and side reach bands</li> </ul>   |
| <b>Visual / Tactile / Audible Feedback</b> | <ul style="list-style-type: none"> <li>• Colour or tonal contrast <math>\geq 70\%</math></li> <li>• Raised symbols or tactile identifiers</li> <li>• Audible and/or visual confirmation of activation</li> </ul>  | <ul style="list-style-type: none"> <li>• Provide multi-sensory feedback</li> <li>• Use non-glare finishes</li> </ul>                                |
| <b>ICT and Self-Service Devices</b>        | <ul style="list-style-type: none"> <li>• Support visual, tactile, audible and optional haptic feedback</li> <li>• Screen mount 1200–1500 mm A.F.F.</li> <li>• Headphone jack and volume control where audio used</li> </ul>                                       | <ul style="list-style-type: none"> <li>• Provide alternative formats (Braille, audio, captions, sign language)</li> <li>• Mitigate glare</li> </ul> |
| <b>Security and Access Systems</b>         | <ul style="list-style-type: none"> <li>• Card readers and intercoms 900–1100 mm A.F.F.</li> <li>• Outside door swing with 600–1500 mm lateral clearance</li> <li>• Audible and visual access</li> </ul>   | <ul style="list-style-type: none"> <li>• Synchronize with power door operators</li> </ul>   |

| Element                            | Key Requirements / Dimensions  | Notes / References  |
|------------------------------------|--|---|
|                                    | confirmation   |   |
| <b>Environmental and Placement</b> | <ul style="list-style-type: none"> <li>• Located along accessible routes</li> <li>• Weather-protected, non-glare surfaces for outdoor controls</li> <li>• Avoid protruding-object hazards</li> </ul> | <ul style="list-style-type: none"> <li>• Group controls at consistent heights for predictability</li> </ul> |

## 5.2 Assistive Listening Devices

### Rationale

Assistive listening devices enhance speech clarity in noisy environments and must be usable by individuals with or without hearing aids. They are essential in spaces where conversation or verbal communication is expected. Providing these devices helps support people who may have difficulty hearing and ensures equitable access to information and services.

In addition, appropriate lighting supports communication for people who rely on lip reading or need enhanced visibility due to vision loss. Adequate, well-controlled lighting improves the ability to follow conversations and enhances the overall accessibility of the space.

### Application

This section applies to assembly areas where audible communication is a key part of how the space is used—such as theatres, meeting rooms, classrooms, auditoriums, and similar environments.

These spaces must include a permanently installed assistive listening system when they:

- Accommodate 50 or more people
- Use audio amplification systems
- Have a floor area greater than 100 m<sup>2</sup> (1080 sq. ft.) and include fixed seating

For smaller or more flexible assembly areas, either a permanently installed system or the infrastructure (such as electrical outlets and wiring) to support a portable assistive listening system must be provided.

At a minimum, 4% of the total seating capacity must have compatible listening receivers available, with no fewer than two receivers provided in any space.

To ensure effective use:

- Ambient noise and other sound sources must not interfere with listening devices
- Dimmer switches and transformer coils must be located to prevent electromagnetic interference with induction loop systems
- In spaces where films are shown, consider providing described video and rear-view captioning to improve accessibility for users with vision or hearing loss

## Design Requirements

### Signage and notification

- Provide signage that meets the requirements of Section 5.9 Signage and Wayfinding, to inform users that assistive listening systems are available

### Types of Assistive Listening Systems

Acceptable types of assistive listening systems include:

- Induction loop systems
- Infrared systems
- FM radio frequency systems

## System Design Considerations

### Induction Loop Systems

- Ensure dimmer switches or controls with transformer coils are placed at least 1200 mm away to avoid electromagnetic interference

### Infrared Systems

- Overhead incandescent lighting must be located at least 2500 mm from infrared receivers to avoid interference

### FM Systems

- Must be compatible with personal hearing aids
- Provide portable headsets when required

### Seating Requirements for Induction Loops

- The loop must cover at least 50% of the seating area
- Fixed seats connected to the system must be within 15 m of the sound source (e.g., stage or presenter)
- Seats must have an unobstructed view of the event space

## Location Requirements

Install assistive listening systems in:

- Classrooms
- Auditoriums
- Theatres
- Exercise rooms
- Meeting/conference rooms
- Service counters (see 6.7 Service Counters)

- Other assembly spaces:
  - At least 100 m<sup>2</sup> in size
  - Designed for 25 people or more

### Additional Design Criteria

- Systems must include:
  - FM, infrared, or induction loop technologies
- Systems must be compatible with personal hearing aids or offer accessible headsets
- Maintain minimum spacing of 1500 mm between dimmer switches and induction loops
- Ensure acoustic conditions align with Section 5.5 Acoustics for sound quality

**Table 77: Assistive Listening Devices at a Glance**

| Element                        | Key Requirements / Dimensions  | Notes / References  |
|--------------------------------|--|---|
| <b>Applicability</b>           | <ul style="list-style-type: none"> <li>• Required in assembly spaces accommodating <math>\geq 50</math> people, with audio amplification, or <math>\geq 100</math> m<sup>2</sup> floor area with fixed seating</li> <li>• Smaller or flexible spaces must have wiring/infrastructure for portable systems</li> </ul> | <ul style="list-style-type: none"> <li>• Applies to theatres, auditoriums, classrooms, meeting rooms, gyms and similar areas</li> </ul> |
| <b>System Capacity</b>         | <ul style="list-style-type: none"> <li>• Provide receivers for at least 4 % of total seating (min 2 receivers per space)</li> </ul>  | <ul style="list-style-type: none"> <li>• Include compatible headsets for users without hearing aids</li> </ul>                          |
| <b>Acceptable System Types</b> | <ul style="list-style-type: none"> <li>• Induction loop systems</li> <li>• Infrared systems</li> <li>• FM radio frequency systems</li> </ul>   | <ul style="list-style-type: none"> <li>• Systems must be compatible with personal hearing aids</li> </ul>                               |
| <b>Induction Loop Systems</b>  | <ul style="list-style-type: none"> <li>• Keep dimmer switches / transformer coils <math>\geq 1200</math> mm away to prevent interference</li> </ul>  | <ul style="list-style-type: none"> <li>• Ensure electromagnetic isolation from nearby wiring</li> </ul>                                 |
| <b>Infrared Systems</b>        | <ul style="list-style-type: none"> <li>• Overhead incandescent lighting <math>\geq 2500</math> mm from receivers</li> </ul>  | <ul style="list-style-type: none"> <li>• Prevent light-source interference</li> </ul>   |
| <b>FM Systems</b>              | <ul style="list-style-type: none"> <li>• Compatible with hearing aids / provide portable headsets</li> </ul>   | <ul style="list-style-type: none"> <li>• Used where loops or infrared are not practical</li> </ul>                                      |

| Element                             | Key Requirements / Dimensions  | Notes / References  |
|-------------------------------------|--|---|
| <b>Seating Coverage (for loops)</b> | <ul style="list-style-type: none"> <li>• Cover <math>\geq</math> 50 % of seating area</li> <li>• Seats connected to system <math>\leq</math> 15 m from sound source</li> <li>• Clear sightlines required</li> </ul>    | <ul style="list-style-type: none"> <li>• Ensure even sound distribution and usability</li> </ul>                |
| <b>Environmental Considerations</b> | <ul style="list-style-type: none"> <li>• Minimize ambient noise and electromagnetic interference</li> </ul>  | <ul style="list-style-type: none"> <li>• Coordinate with Section 5.5 Acoustics</li> </ul>                       |
| <b>Signage and Notification</b>     | <ul style="list-style-type: none"> <li>• Provide signage indicating availability of assistive listening system</li> <li>• Must meet Section 5.9 Signage and Wayfinding</li> </ul>                                      | <ul style="list-style-type: none"> <li>• Use International Symbol for Assistive Listening Systems</li> </ul>    |
| <b>Additional Design Criteria</b>   | <ul style="list-style-type: none"> <li>• Maintain <math>\geq</math> 1500 mm spacing between dimmer switches and induction loops</li> <li>• Systems must support FM, infrared or induction loop technologies</li> </ul> | <ul style="list-style-type: none"> <li>• Provide accessible volume and balance controls on receivers</li> </ul> |

## 5.3 Public Address Systems

### Rationale

Public address (PA) systems distribute important messages clearly across large areas. These systems must work in a variety of environments and be usable by everyone, including those with hearing loss or cognitive disabilities.

They should be free from echoes, distortion, or feedback, and background noise should be minimized. For individuals who are deaf or hard of hearing, PA announcements should be supported with visual or alternative formats.

### Application

This section applies to all facilities using PA systems for emergency, safety, or operational messaging.

### Design Requirements

#### Speaker Placement

- Install overhead speakers at a minimum height of 2100 mm A.F.F.
- In large open areas, speakers should be spaced every 600–900 mm depending on room acoustics

#### Sound Coverage and Volume

- Adjust speaker output to 10–15 dB above ambient background noise
- Use directional speakers in noisy zones

#### Acoustic Treatment

- Use acoustic panels or other sound-absorbing materials in echo-prone areas

#### Paging Systems

- Paging systems for staff or other key persons must be discreet and low volume
- Use directional or local speakers in private/semi-private zones to avoid disruption

Table 78: Public Address (PA) Systems At a Glance

| Element  | Key Requirements / Dimensions   | Best Practices / Notes   |
|--|---|--|
| <b>Speaker Placement</b>                           | <ul style="list-style-type: none"> <li>• Overhead speakers <math>\geq 2100</math> mm A.F.F.</li> <li>• Spaced every 600–900 mm depending on acoustics</li> </ul>                | <ul style="list-style-type: none"> <li>• Avoid placing directly over reflective surfaces</li> <li>• Provide even coverage and minimize dead zones</li> </ul>                           |
| <b>Sound Coverage &amp; Volume</b>                 | <ul style="list-style-type: none"> <li>• 10–15 dB above ambient background noise</li> </ul>   | <ul style="list-style-type: none"> <li>• Maintain Speech Transmission Index (STI) <math>\geq 0.6</math></li> <li>• Background noise <math>\leq 55</math> dBA where possible</li> </ul> |
| <b>Acoustic Treatment</b>                          | <ul style="list-style-type: none"> <li>• Use sound-absorbing materials in echo-prone areas</li> </ul>   | <ul style="list-style-type: none"> <li>• Install acoustic ceiling tiles or panels to reduce reverberation time to <math>\leq 1.0</math> s in occupied areas</li> </ul>                 |
| <b>Paging Systems</b>                              | <ul style="list-style-type: none"> <li>• Use directional or local speakers in private/semi-private zones</li> <li>• Operate at low volume</li> </ul>                            | <ul style="list-style-type: none"> <li>• Ensure paging signals do not interfere with assistive listening systems</li> </ul>  |
| <b>Visual &amp; Alternative Formats (optional)</b> | <ul style="list-style-type: none"> <li>• Provide visual message boards or text displays for critical announcements</li> <li>• Integrate with emergency alert systems</li> </ul> | <ul style="list-style-type: none"> <li>• Complies with Toronto and CSA best practice for redundant communication modes</li> </ul>  |

## 5.4 Accessible Public Telephones

### Rationale

Although mobile phones are widely used, accessible public telephones ensure that everyone—especially those without mobile access—can make calls in public. Design considerations such as reach range, cord length, adjustable volume, and TTY compatibility support individuals with mobility, vision, and hearing disabilities.

Accessible design also prevents wall-mounted telephones from becoming hazards for people with vision loss and ensures all users can operate the phone safely and independently.

### Application

This section applies to all:

- Indoor and outdoor public-use telephones
- Coin-operated, coin-less, and courtesy phones
- Telephones regulated by the CRTC

Where public telephones are provided, they must comply with this section. CRTC-regulated phones must comply with all requirements except for signals and controls.

- At least one accessible telephone is required per floor or per bank of phones
- A minimum of 25% of all public telephones must have volume control (never fewer than one)
- Where an interior public payphone is provided, at least one TTY device must also be available
- In detention or correctional facilities, at least one TTY must be available in a secured area

**Table 79: Where Telephones are Provided, Number of Accessible Telephones**

| Number of each type of telephone provided on each floor | Number of accessible telephones for persons who use wheelchairs or scooters   | Number of accessible telephones for persons who are deaf, deafened or hard of hearing   |
|---|---|---|
| 1 or more single units                                  | 1 per floor   | 1 per floor   |
| 1 bank  | 1 per floor   | 1 per floor   |
| 2 or more banks   | 1 per bank<br>Accessible phones may be installed as single units in proximity to (i.e. either visible or with signage) the bank. At least one public telephone per floor shall meet the requirements for a forward reach telephone. | 1 per bank<br>Accessible phones may be installed as single units in proximity to (i.e. either visible or with signage) the bank. At least one public telephone per floor shall meet the requirements for a forward reach telephone. |

Note: A bank consists of two or more adjacent public telephones, often installed as a unit.

## Design Requirements

### Location and Access

- Must be located along an accessible route
- Telephone hardware must comply with 2.6 Overhead and Protruding Objects

### Accessible Path of Travel

- Ensure a continuous, unobstructed route to all accessible telephones

### Clear Floor Space

- For front approach: minimum 900 mm x 1500 mm
- For parallel approach: as per Figures XYZ and XYZ

### Shelves and Reach Ranges

- Shelf: minimum 500 mm wide x 350 mm deep
- Clearance above shelf: minimum 250 mm
- Shelf height: between 775 mm and 875 mm
- Knee/toe clearance:
  - Height: min. 740 mm
  - Depth: 500 mm
  - Width: 900 mm

## Handsets and Controls

- Push-button controls with high contrast and matte finish
- Handset cord length: minimum 1000 mm
- Illuminated at 200 lux at shelf and controls
- Mount all operable parts no higher than 1050 mm
- Must comply with CSA Standard T515

## TTY Devices

- TTYs must be permanently mounted within or beside the enclosure
- Must include acoustic couplers and accessible outlets for power

## New Technology

- Consider video relay systems or other evolving accessibility tools

## Identification and Signage

- Clearly identify accessible phones with appropriate symbols (mobility, deaf/hard of hearing)
- Signage must meet 3.2.1 for wayfinding and be provided for TTYs and accessible phones

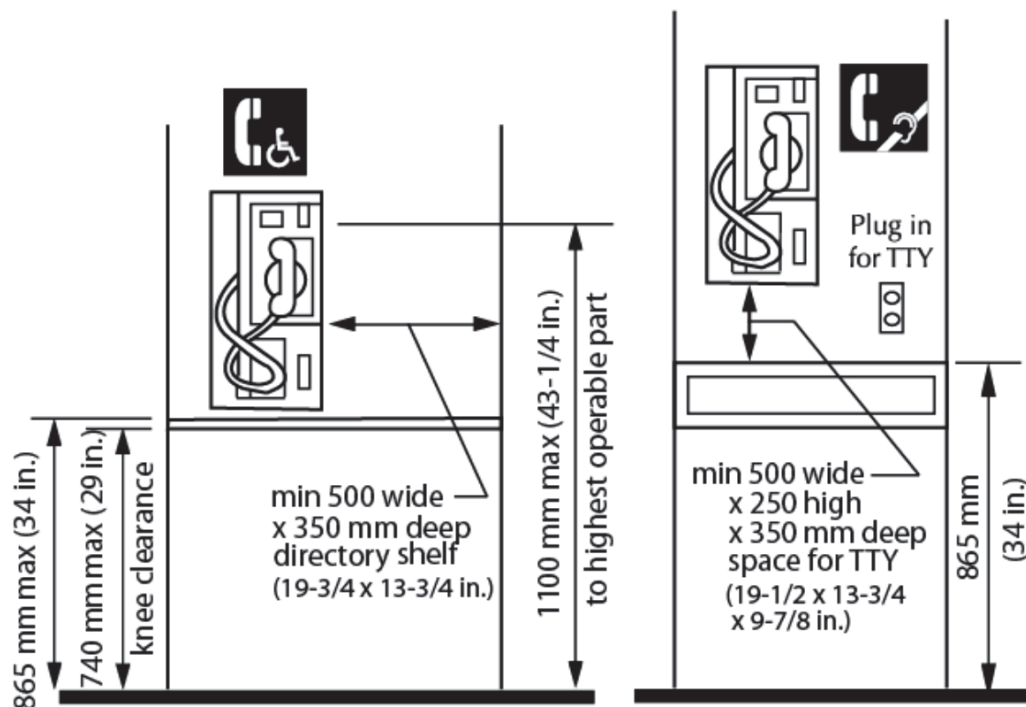

Figure 131: Accessible Telephone for Seated User and Accessible Telephone for Individuals who are Deaf, Deafened, Hard of Hearing or Speech-Impaired

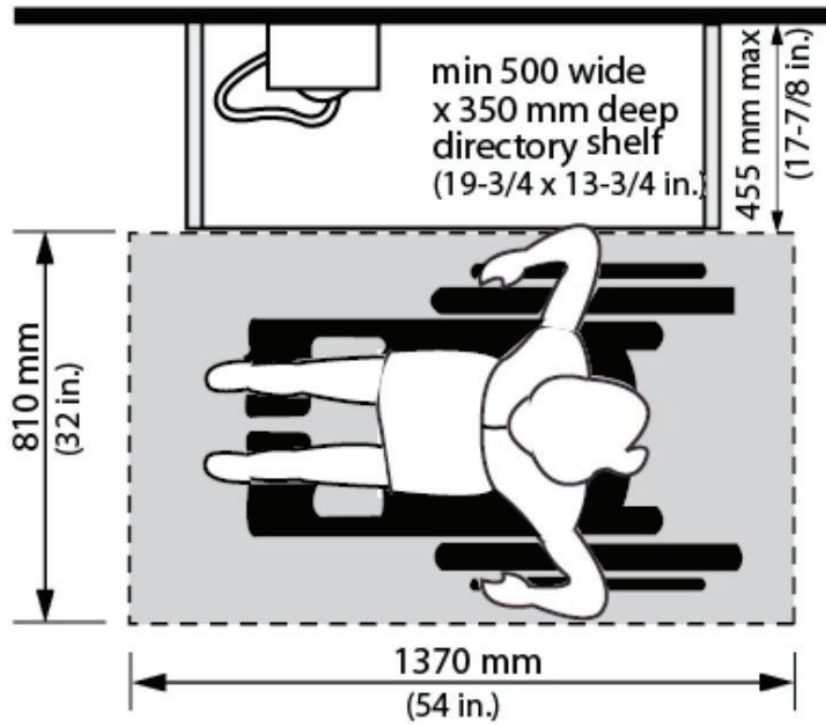

Figure 132: Parallel Approach to a Public Telephone

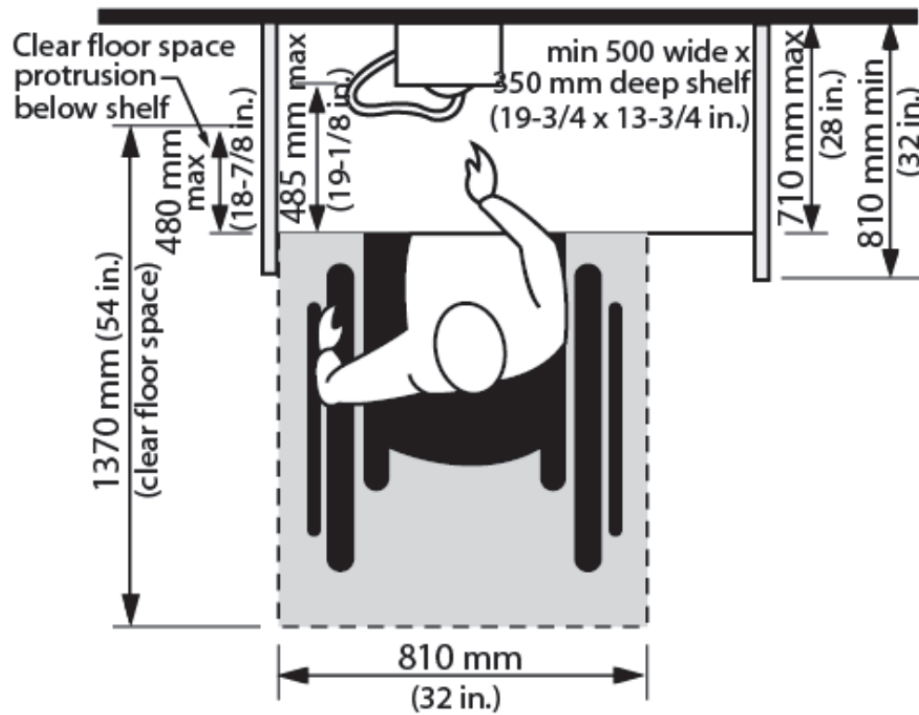
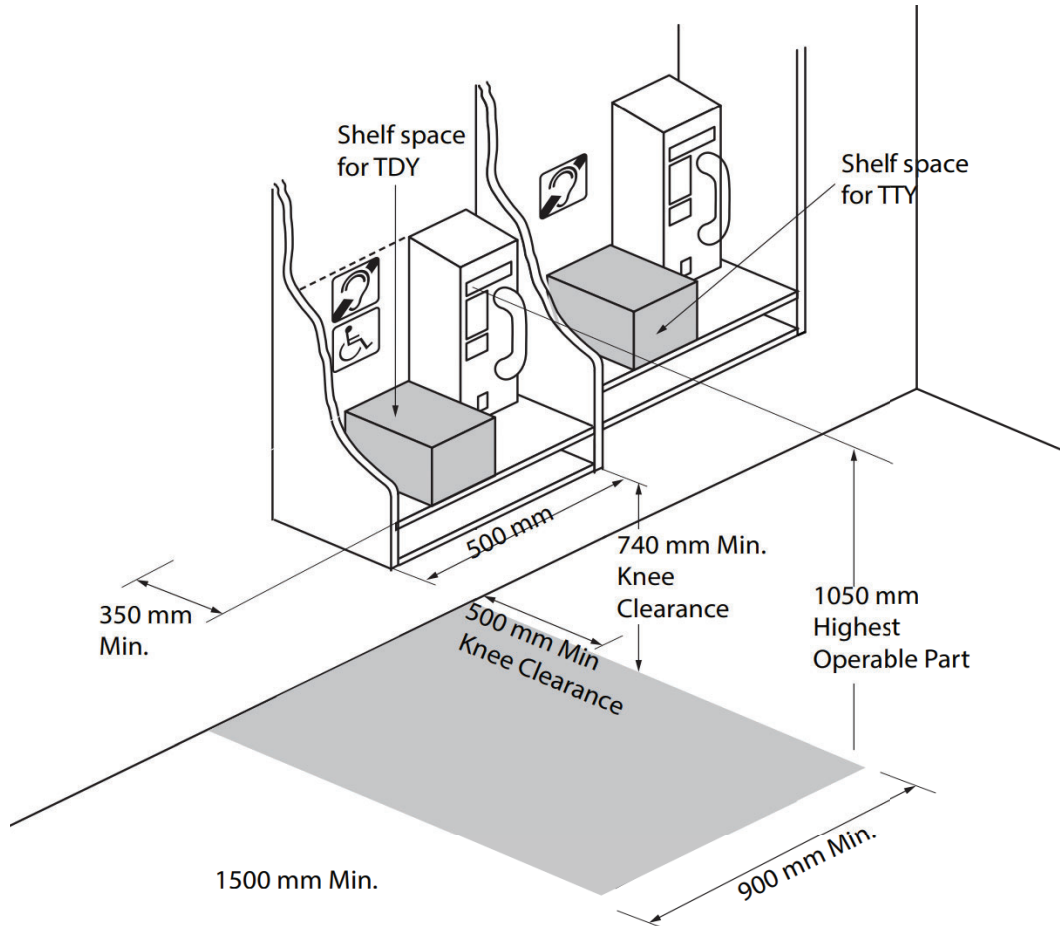

Figure 133: Forward Approach to a Public Telephone



**Figure 134: Public Telephones**

**Table 80: Public Telephones At a Glance**

| Element                                | Key Requirements / Dimensions   | Notes / References   |
|--|---|--|
| <b>Accessible Telephones (General)</b> | <ul style="list-style-type: none"> <li>• Located on accessible route</li> <li>• 1 per floor or per bank</li> <li>• ≥ 25 % with volume control</li> <li>• TTY at each interior location</li> </ul> | <ul style="list-style-type: none"> <li>• See Table XYZ for required numbers</li> </ul> |
| <b>Clear Floor Space</b>               | <ul style="list-style-type: none"> <li>• Front = 900 × 1500 mm</li> <li>• Parallel = per Fig 4.4.5.3–4</li> <li>• Knee 740 mm H × 500 mm D × 900 mm W</li> </ul>                                  | <ul style="list-style-type: none"> <li>• Maintain unobstructed approach</li> </ul>     |
| <b>Shelf &amp; Reach</b>               | <ul style="list-style-type: none"> <li>• Shelf 500 W × 350 D</li> <li>• Height 775–875 mm</li> <li>• Clearance ≥ 250 mm</li> </ul>  |  |

| Element                         | Key Requirements / Dimensions  | Notes / References  |
|---------------------------------|--|---|
|                                 | <ul style="list-style-type: none"> <li>• Reach 460–1050 mm A.F.F.</li> </ul>   |   |
| <b>Handsets / Controls</b>      | <ul style="list-style-type: none"> <li>• High-contrast push buttons</li> <li>• Cord <math>\geq</math> 1000 mm</li> <li>• Lighting <math>\geq</math> 200 lux</li> <li>• Operable <math>\leq</math> 1050 mm</li> <li>• Force <math>\leq</math> 22 N</li> </ul> | <ul style="list-style-type: none"> <li>• Must comply CSA T515</li> </ul>                              |
| <b>TTY Devices</b>              | <ul style="list-style-type: none"> <li>• Permanently mounted</li> <li>• Acoustic couplers</li> <li>• Accessible outlets</li> <li>• Adjacent to phone</li> </ul>  | <ul style="list-style-type: none"> <li>• One per floor or bank minimum</li> </ul>                     |
| <b>Signage / Identification</b> | <ul style="list-style-type: none"> <li>• Accessibility symbols</li> <li>• Meets Section 5.9 Signage &amp; Wayfinding</li> </ul>  | <ul style="list-style-type: none"> <li>• Include mobility and deaf/hard-of-hearing symbols</li> </ul> |
| <b>Lighting &amp; Safety</b>    | <ul style="list-style-type: none"> <li>• Illumination <math>\geq</math> 200 lux at controls</li> <li>• No protruding hazards</li> </ul>  | <ul style="list-style-type: none"> <li>• Aligns with universal design principles</li> </ul>           |

## 5.5 Acoustics

### Rationale

Sound is an essential part of how people experience spaces. For some, it's about hearing speech clearly in a meeting. For others, it's about avoiding sensory overload in noisy areas. For people who are blind or have low vision, sound also acts as a wayfinding tool. Inclusive acoustic design makes spaces easier to navigate, more comfortable to use, and more welcoming for everyone.

### Application

These requirements apply to publicly accessible spaces, especially those where communication or orientation depends on clear sound, such as lobbies, service counters, classrooms, auditoriums, and large open areas.

### Design Requirements

#### Limit background noise

- Select mechanical systems and equipment designed for quiet operation (where possible)
- Isolate or buffer noisy areas (e.g., mechanical rooms, busy corridors) from quieter spaces

#### Reduce echoes and reverberation

- Use acoustic ceiling tiles, wall panels, and soft floor finishes where possible
- Avoid untreated parallel hard surfaces that bounce sound back and forth
- Use layouts that limit sound transmission between adjacent rooms where privacy is important
- Where sound privacy is required (e.g., interview rooms, counselling areas, customer service spaces), use partitions or acoustic baffles to achieve adequate speech privacy without impairing accessibility

#### Improve speech clarity

- Balance sound-absorbing and sound-reflecting surfaces
- Support the use of assistive listening systems (e.g., induction loops, FM systems, infrared) in spaces where sound amplification is provided, such as meeting rooms and auditoriums

## Support orientation by sound

- Allow for subtle differences in floor and wall finishes so that spaces sound distinct without being confusing

## Ensure public announcements are intelligible

- Use zoned public address systems
- Test speech intelligibility during commissioning
- Ensure PA systems integrate with assistive listening systems or have equivalent visual notification options

## Technical Note – Acoustic Performance Targets

While this standard focuses on accessibility considerations, detailed acoustic performance targets (such as reverberation time, background noise and speech transmission indices) should be determined by qualified acoustical consultants. These targets should be consistent with recognized standards and certification systems, such as:

- **CSA Z317.2** (special requirements for healthcare facilities)
- **ISO 3382 / ISO 16283** (measurement of reverberation and sound insulation)
- **WELL Building Standard** - Sound concept (comfort feature)
- **LEED v4/v5** - Acoustic performance credit (schools, healthcare and workplaces)

Design teams are encouraged to apply these benchmarks where relevant to ensure high quality, equitable, and sustainable acoustic environments.

**Table 81: Acoustics at a Glance**

| Feature                                   | Minimum / Recommended Dimensions                        | Notes / Key Requirements  |
|---|---|---|
| <b>Background Noise Control</b>           | <ul style="list-style-type: none"> <li>• N/A</li> </ul> | <ul style="list-style-type: none"> <li>• Select quiet mechanical / electrical systems</li> <li>• Isolate noisy spaces from quiet ones</li> <li>• Maintain consistent ambient sound levels for comfort</li> </ul>                        |
| <b>Echo &amp; Reverberation Reduction</b> | <ul style="list-style-type: none"> <li>• N/A</li> </ul> | <ul style="list-style-type: none"> <li>• Use acoustic ceiling tiles, wall panels, or soft floor finishes</li> <li>• Avoid untreated parallel hard surfaces</li> <li>• Introduce baffles or absorptive materials where needed</li> </ul> |

| <b>Feature</b>                          | <b>Minimum / Recommended Dimensions</b>   | <b>Notes / Key Requirements</b>  |
|---|---|--|
| <b>Speech Clarity</b>                   | <ul style="list-style-type: none"> <li>N/A</li> </ul>   | <ul style="list-style-type: none"> <li>Balance reflective and absorptive surfaces</li> <li>Provide assistive listening systems in amplified spaces (induction loop, FM, infrared)</li> </ul> |
| <b>Orientation by Sound</b>             | <ul style="list-style-type: none"> <li>N/A</li> </ul>   | <ul style="list-style-type: none"> <li>Use subtle material or layout differences for distinguishable auditory cues</li> <li>Avoid confusing or competing sound sources</li> </ul>            |
| <b>Public Announcements</b>             | <ul style="list-style-type: none"> <li>N/A</li> </ul>   | <ul style="list-style-type: none"> <li>Use zoned PA systems</li> <li>Test speech intelligibility</li> <li>Integrate with assistive listening or visual alert systems</li> </ul>              |
| <b>Assistive Listening Systems</b>      | <ul style="list-style-type: none"> <li>As per CSA Z614, ISO 3382 / 16283, WELL, LEED</li> </ul> | <ul style="list-style-type: none"> <li>Provide in meeting rooms, auditoriums, or amplified spaces</li> <li>Include signage per Section 5.9 Signage and Wayfinding</li> </ul>                 |
| <b>Technical Performance Benchmarks</b> | <ul style="list-style-type: none"> <li>Referenced Standards</li> </ul>                          | <ul style="list-style-type: none"> <li>Use CSA Z317.2 (healthcare), ISO 3382 / 16283 for measurement, WELL and LEED for acoustic criteria</li> </ul>   |

## 5.6 Security Systems

### Rationale

Security is not just about keeping people out — it's about making sure everyone who belongs can get in, safely and independently. Card readers, keypads, and other systems should be easy to reach, simple to use, and provide clear confirmation. When designed inclusively, security systems protect people while supporting dignity, independence, and comfort.

### Application

Applies to all entrances, exits, secured rooms, and public service areas that require controlled access.

### Design Considerations

#### Accessible Path of Travel

- Provide a continuous, unobstructed route to security controls and card access points
- Ensure clear floor space for users of mobility devices (See Section 2.1 Space and Reach Requirements)

#### Control Design and Placement

- Install card readers, keypads, or sensors within accessible reach ranges for seated and standing users (generally 900–1200 mm A.F.F.)
- Mount controls a minimum of 600 mm laterally from the arc of any door swing (see Figure XYZ)
- Ensure controls can be operated with one hand without tight grasping, pinching, or twisting
- Provide tactile or raised markings on keypads and controls
- Refer to Section 5.1 Controls and Operating Mechanisms for detailed reach ranges and operability criteria

#### Feedback and Usability

- Provide both visual and audible confirmation when access is granted or denied
- Ensure alarms or notifications are distinct and easy to recognize
- Where possible, use high visual contrast between controls and background surfaces to aid visibility and predictability

## Safety and Security

- Provide timed entry settings that allow sufficient time for users with disabilities
- Ensure alternative or emergency access options are available in case of system failure
- Security features must include fail-safe, automatic release mechanisms that disengage during fire alarm activation, power failure, or other emergencies

## Durability and Maintenance

- Use durable materials suitable for high use and outdoor conditions
- Ensure weather protection and non-glare finishes for exterior devices
- Regularly test systems for accessibility, functionality, and reliability

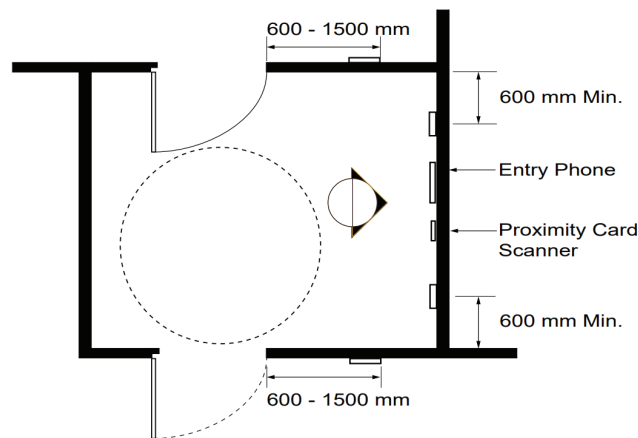

Plan

**Figure 135: Card Access and Building Security Systems - Plan View**

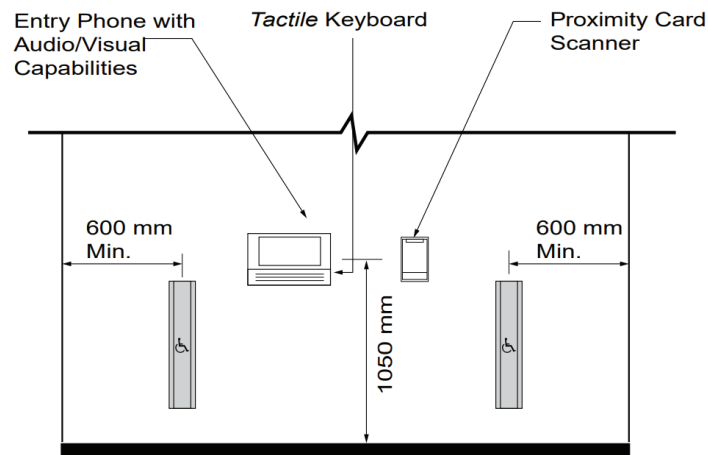

Elevation

**Figure 136: Card Access and Building Security Systems - Elevation View**

## Technical Note – Security and Access Control Standards

While this manual sets accessibility requirements, detailed specifications for security systems (such as detection ranges, keypad layouts, or lighting levels) should follow recognized standards and industry best practices, including:

- CSA B651 (Accessible design for the built environment)
- ISO 21542 (Building construction – Accessibility and usability of the built environment)
- UL 294 (Access control system units)
- CPTED (Crime Prevention Through Environmental Design guidelines)

Design teams should apply these standards and involve security and accessibility specialists to ensure systems are both secure and inclusive.

### Cross-Reference Note

Card access and security systems must be designed in coordination with fire and life safety systems. Access-controlled doors and secured areas must not create barriers to emergency egress, and all security features should release or override automatically in the event of fire alarm activation, power failure, or other emergencies.

See also: Section 5.7 Fire and Life Safety Systems.

**Table 82: Security Systems at a Glance**

| <b>Feature / Element</b>         | <b>Requirement / Recommended Range</b>   | <b>Notes / Best Practices</b>   |
|----------------------------------|--|---|
| <b>Accessible Path of Travel</b> | <ul style="list-style-type: none"> <li>• Continuous, unobstructed route to controls and access points</li> </ul>     | <ul style="list-style-type: none"> <li>• Must connect to exterior/interior accessible routes per Section 2.1</li> </ul> |
| <b>Mounting Height</b>           | <ul style="list-style-type: none"> <li>• 900 – 1200 mm A.F.F.</li> </ul>   | <ul style="list-style-type: none"> <li>• Within reach range for seated and standing users</li> </ul>                    |
| <b>Clearance from Door Swing</b> | <ul style="list-style-type: none"> <li>• <math>\geq 600</math> mm lateral clearance from door swing arc</li> </ul>   | <ul style="list-style-type: none"> <li>• Prevents collision and ensures approach access</li> </ul>                      |
| <b>Clear Floor Space</b>         | <ul style="list-style-type: none"> <li>• 900 × 1500 mm (front); 900 × 2200 mm (side)</li> </ul>                      | <ul style="list-style-type: none"> <li>• As per Section 2.1 Space and Reach Requirements</li> </ul>                     |
| <b>Operability</b>               | <ul style="list-style-type: none"> <li>• One-hand use</li> <li>• No tight grasping, pinching, or twisting</li> </ul> | <ul style="list-style-type: none"> <li>• Refer to Section 5.1 Controls and Operating Mechanisms</li> </ul>              |

| Feature / Element               | Requirement / Recommended Range   | Notes / Best Practices   |
|---------------------------------|---|--|
| <b>Feedback</b>                 | <ul style="list-style-type: none"> <li>• Visual + audible confirmation of granted/denied access</li> </ul>                    | <ul style="list-style-type: none"> <li>• Colour contrast recommended</li> <li>• Feedback distinct from alarms</li> </ul> |
| <b>Timed Entry</b>              | <ul style="list-style-type: none"> <li>• Adjustable to accommodate users with disabilities</li> </ul>                         | <ul style="list-style-type: none"> <li>• Allow sufficient time for mobility device users</li> </ul>                      |
| <b>Emergency Override</b>       | <ul style="list-style-type: none"> <li>• Fail-safe</li> <li>• Automatic release during fire alarm or power failure</li> </ul> | <ul style="list-style-type: none"> <li>• Must not impede egress</li> <li>• Fail-safe design required</li> </ul>          |
| <b>Durability / Maintenance</b> | <ul style="list-style-type: none"> <li>• Weather- and tamper-resistant materials</li> <li>• Routine testing</li> </ul>        | <ul style="list-style-type: none"> <li>• For exterior use, provide weather protection and non-glare finishes</li> </ul>  |
| <b>Applicable Standards</b>     | <ul style="list-style-type: none"> <li>• CSA B651, ISO 21542, UL 294, CPTED</li> </ul>  | <ul style="list-style-type: none"> <li>• Apply through coordination with security/access consultant</li> </ul>           |

## 5.7 Fire and Life Safety Systems

### Rationale

All municipal facilities must ensure safe, timely evacuation for every occupant. Fire and life safety systems provide clearly marked, protected evacuation routes and temporary safe waiting areas (Areas of Refuge) for individuals who cannot use stairs.

Designing these systems with accessibility, redundancy and inclusivity in mind protects all users — including those with mobility, sensory or cognitive disabilities — while supporting the principles of universal design.

### Application

This section applies to all newly constructed and renovated municipal facilities where emergency evacuation is required.

Areas of Refuge and accessible emergency exits must be provided in buildings where:

- Multi-storey buildings above or below grade
- Layouts are complex or contain multiple exits
- Some occupants may need assistance or additional time to evacuate

Emergency evacuation strategies must address the needs of individuals who:

- Use mobility devices
- Are blind or have low vision
- Are deaf, deafened or hard of hearing
- Have cognitive or other disabilities
- Staff and visitors unfamiliar with the facility

### Design Requirements

All fire alarm system components, installation, placement, performance and audibility/visibility requirements must comply with the Ontario Building Code (OBC) and CAN/ULC-S524, Installation of Fire Alarm Systems.

This standard governs device location, installation height, sound pressure levels, visual signal synchronisation and system integration. FADS requirements are intended to complement — not override — CAN/ULC-S524.

## Accessible Emergency Routes

- Provide at least one accessible route per floor connecting to a safe exit or Area of Refuge
- Minimum width 1100 mm; firm, stable, non-slip surfaces
- Equipped with emergency lighting and tactile wayfinding (see Section 5.9 Signage and Wayfinding)
- Routes should minimize travel distance and avoid obstacles

## Areas of Refuge (AR)

Areas of Refuge are temporary safe waiting spaces for evacuation, allowing occupants unable to use stairs to wait for assistance from emergency personnel.

### Quantity

- Provide ARs on every floor without direct accessible exit
- Minimum number of ARs per floor based on Table 5.9.1

**Table 83 - Minimum number of Areas of Refuge**

| Occupancy Load | Minimum ARs   |
|----------------|---|
| 1–400          | 2   |
| Over 400       | 3 plus 1 for each additional 200 occupants beyond 400 |

### Location

- Located on an accessible route
- Direct connection to a firefighter's elevator preferred, or adjacent to a fire-rated exit stairwell
- Door must comply with Section 3.2 Doors and Doorways

### Design and Layout

- Minimum clear floor area 920 mm by 1500 mm
- Smoke-protected and fire-rated enclosure
- Integrated into the facility's fire safety plan

### Signage

- High contrast signage with tactile characters and Braille
- Clearly identifies "AREAS OF REFUGE" (See section 5.9 Signage and Wayfinding)
- Mounted in visible, consistent locations

## Communication and Emergency Features

- Two-way communication system connected to central monitoring (e.g., reception, security)
- Both visual and audible emergency alarms

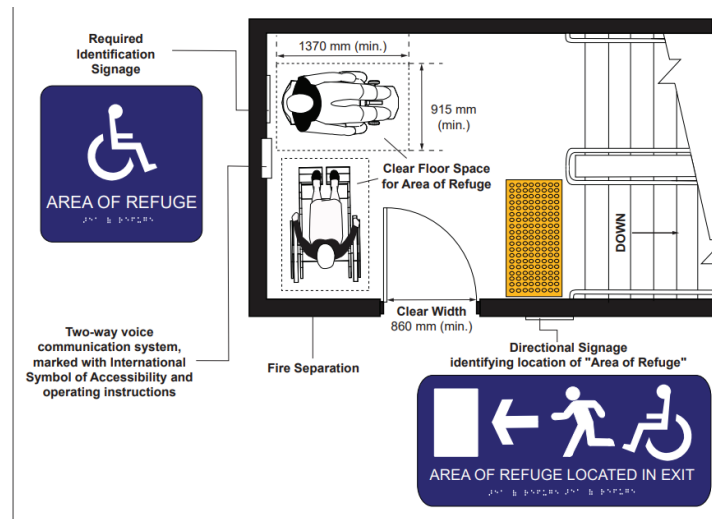

Figure 137: Area of Rescue Assistance

## Fire Evacuation Staircases

- Fire-rated, protected stairwells connecting all floors
- Minimum width 1100 mm, minimum head clearance 2100 mm
- Landings allow turning for mobility devices, minimum 1500 mm by 1500 mm where possible
- Tactile walking surface indicators (TWSI) at top and bottom of stairs
- High-contrast edges on treads and risers
- Handrails extend 300 mm beyond top and bottom steps
- Lever-style handles, tactile/Braille signage
- Emergency lighting connected to battery or generator backup

## Emergency Alarms

- Visual alarms (strobes) for persons who are deaf or hard of hearing
- Provide audible alarms that are at least 15dB above ambient noise, without exceeding maximum sound pressure limits defined in CAN/ULC-S524
- All devices must be connected to the fire alarm control panel and backup power
- Install alarms in::

- All public-use and assembly spaces
- Corridors and lobbies
- Washrooms
- Meeting rooms and multi-purpose spaces
- Areas of Refuge

Alarm systems must comply with the Ontario Building Code and be integrated with facility fire and life safety systems.

**Note:** Designers must ensure that both minimum audibility ( $\geq 15$  dB above ambient) and maximum allowable dB thresholds are met. Excessively loud alarms can cause harm and may violate CAN/ULC-S524 and OHSA requirements

### **Fire Safety and Evacuation Plans**

- Develop and post a Fire and Life Safety Evacuation Plan addressing the needs of occupants with disabilities
- For floors above or below grade, specify preferred evacuation strategies (e.g., buddy system)
- Post base of plans no higher than 1200 mm A.F.F. with minimum 14 pt font size
- Provide alternate formats upon request (large print, Braille or digital)
- Install signage to identify location of evacuation plans

### **Emergency Equipment Placement**

- Mount emergency and life safety controls between 900–1100 mm A.F.F. (e.g., fire extinguishers, first aid kits, defibrillators)
- Manual fire alarm pull stations mounted at 1200 mm A.F.F.
  - Provide clear floor space 915 mm × 1370 mm
  - Operable with one hand, no tight grasping, pinching, or twisting
  - Maximum activation force 22.2 N

### **Optional Redundancies**

- Smoke-protected lifts for evacuation in tall buildings
- Battery or generator backup for communication and alarms
- Integration with broader emergency and accessibility plans

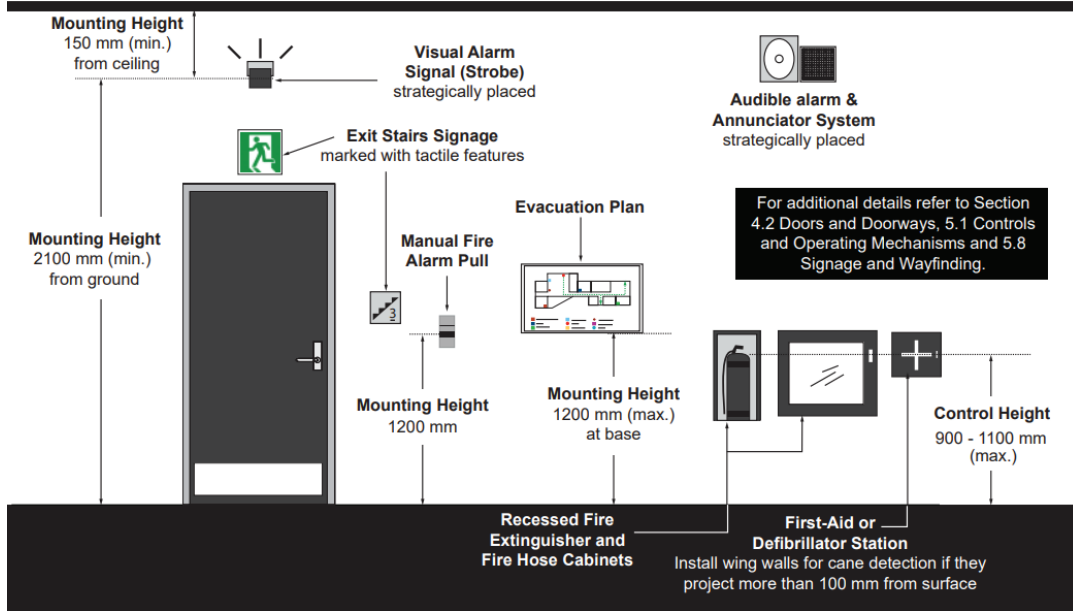

Figure 138: Fire Safety and Evacuation Features - Elevation View

Table 84: Fire and Life Safety Systems at a Glance

| Feature / Element        | Minimum / Recommended Requirements   | Notes / Best Practices   |
|--------------------------|--|--|
| <b>Accessible Routes</b> | <ul style="list-style-type: none"> <li>• ≥ 1100 mm width; firm, stable, non-slip</li> <li>• Emergency lighting</li> </ul>              | <ul style="list-style-type: none"> <li>• Minimize distance</li> <li>• Avoid obstacles</li> <li>• Provide tactile wayfinding</li> </ul>               |
| <b>Areas of Refuge</b>   | <ul style="list-style-type: none"> <li>• ≥ 920 mm × 1500 mm</li> <li>• Smoke-protected</li> <li>• On accessible route</li> </ul>       | <ul style="list-style-type: none"> <li>• Two-way communication</li> <li>• Signage with tactile + Braille</li> <li>• Visual/audible alarms</li> </ul> |
| <b>Minimum AR Count</b>  | <ul style="list-style-type: none"> <li>• 1–400 occupants = 2</li> <li>• &gt;400 = 3 + 1 per 200 additional</li> </ul>                  | <ul style="list-style-type: none"> <li>• Per Table 5.X.1 – adjust by occupant load</li> </ul>  |
| <b>Staircases</b>        | <ul style="list-style-type: none"> <li>• Width ≥ 1100 mm</li> <li>• Headroom ≥ 2100 mm</li> <li>• Landings ≥ 1500 × 1500 mm</li> </ul> | <ul style="list-style-type: none"> <li>• TWSIs at top/bottom</li> <li>• High-contrast edges</li> <li>• Handrails extend 300 mm</li> </ul>            |
| <b>Emergency Alarms</b>  | <ul style="list-style-type: none"> <li>• Visual (strobes) + audible ≥ 15 dB above ambient</li> </ul>                                   | <ul style="list-style-type: none"> <li>• Installed in all public, circulation, and AR spaces</li> <li>• Backup power required</li> </ul>             |

| Feature / Element           | Minimum / Recommended Requirements   | Notes / Best Practices   |
|-----------------------------|--|--|
| <b>Fire Plans / Signage</b> | <ul style="list-style-type: none"> <li>Plans ≤ 1200 mm A.F.F.</li> <li>Min 14 pt font</li> <li>Alt formats available</li> </ul>      | <ul style="list-style-type: none"> <li>Identify location of plans</li> <li>Integrate with emergency preparedness plan</li> </ul> |
| <b>Emergency Controls</b>   | <ul style="list-style-type: none"> <li>Mount 900–1100 mm A.F.F. (fire extinguishers, AEDs)</li> <li>Pull stations 1200 mm</li> </ul> | <ul style="list-style-type: none"> <li>Clear space 915 × 1370 mm</li> <li>Operable with ≤ 22 N force</li> </ul>                  |
| <b>Power / Backup</b>       | <ul style="list-style-type: none"> <li>Generator or battery backups for lighting and alarms</li> </ul>                               | <ul style="list-style-type: none"> <li>Recommended for high occupancy facilities</li> </ul>                                      |
| <b>Integration</b>          | <ul style="list-style-type: none"> <li>Coordinate security and fire systems for safe override</li> </ul>                             | <ul style="list-style-type: none"> <li>Access doors must release automatically during emergencies</li> </ul>                     |

## 5.8 Lighting

### Rationale

Good lighting is essential for safe, comfortable and independent use of facilities. Proper illumination helps people navigate, recognize hazards, read signage, and communicate effectively.

Lighting plays a critical role for individuals with low vision, hearing loss (supporting lip reading and sign language) or cognitive disabilities who may rely on consistent, glare-free lighting for orientation and comfort.

### Application

Applies to interior and exterior public spaces including:

- Entrances and exits
- Paths of travel (indoor and outdoor)
- Stairs and ramps
- Service areas and washrooms

- Meeting rooms and assembly spaces

## Design Requirements

### General Principles

- Provide consistent, evenly distributed lighting in circulation areas, entrances and task spaces
- Avoid glare, sharp contrasts, or abrupt changes in light levels that may cause discomfort or disorientation
- Ensure sufficient lighting to support safe navigation on stairs, ramps, and other level changes

### Exterior Lighting

- Illuminate accessible routes, pedestrian crossings, parking areas and building entrances
- Position fixtures to minimize glare and shadows
- Use weather-resistant fixtures appropriate for Canadian winter conditions
- Coordinate lighting design with accessible wayfinding and security systems for safety and visibility

### Interior Lighting

- Provide uniform lighting levels in corridors, lobbies and gathering areas
- Include task lighting at work surfaces, service counters and washrooms
- Provide dimmable or adjustable lighting in meeting rooms, assembly areas and performance spaces to accommodate interpreters, presenters or visual media use

### Accessibility Considerations

- Ensure lighting enhances visibility of signage, entrances, hazards and changes in elevation
- Provide vertical illumination where face-to-face communication, lip reading or facial recognition occurs
- Avoid lighting that causes reflections or obscures glazing; use frosted markings or decals to make transparent walls visible
- Position luminaires to minimize flicker and shadows on accessible routes

### Reference – Typical Minimum Illumination Levels

(measured at ground/task level)

The following values represent minimum illumination levels for common spaces to support accessibility and safety. Designers should reference IESNA, CSA and WELL standards for detailed performance targets.

- **Exterior:** Lighting should support safe access from parking areas, sidewalks, and drop-off zones to building entrances, minimizing glare and shadows
- **Interior:** Lighting should provide consistent, even illumination in circulation areas and task spaces, with adjustments available where user needs vary

**Table 85: Minimum Illumination Levels**

| Location / Task Area  | Minimum Lighting Level (lux) | Notes  |
|---|------------------------------|--|
| Entrances (indoor & outdoor)  | 100                          | <ul style="list-style-type: none"> <li>• Ensure gradual transition between interior and exterior lighting levels</li> </ul>      |
| Accessible paths of travel (indoor & outdoor, including stairs and ramps) | 50                           | <ul style="list-style-type: none"> <li>• Consistent, even lighting</li> <li>• Avoid glare and shadows</li> </ul>                 |
| Parking areas & passenger drop-off  | 30                           | <ul style="list-style-type: none"> <li>• Improve visibility and safety in exterior circulation</li> </ul>                        |
| Washrooms & change rooms  | 200                          | <ul style="list-style-type: none"> <li>• Even distribution</li> <li>• Avoid glare from mirrors or reflective surfaces</li> </ul> |
| Service counters / reception desks  | 300                          | <ul style="list-style-type: none"> <li>• Measured at task surface</li> <li>• Support face-to-face communication</li> </ul>       |
| Offices / work areas  | 300–500                      | <ul style="list-style-type: none"> <li>• Higher levels may be needed for detailed visual tasks</li> </ul>                        |
| Meeting & assembly rooms  | 200 (general) / adjustable   | <ul style="list-style-type: none"> <li>• Provide dimming/zoning to accommodate interpreters, presentations</li> </ul>            |

\*Values are minimums; higher lighting may be required for specific users or tasks

## Technical Note – Lighting Performance Standards

This section outlines accessibility outcomes. Detailed lighting performance specifications (e.g.,

lux levels, glare ratings color rendering) should be developed by qualified lighting designers in accordance with recognized standards, such as:

- **IESNA** (Illuminating Engineering Society of North America) Lighting Handbook
- **CSA B651** (Accessible Design for the Built Environment)
- **CIE** (Commission Internationale de l'Éclairage) glare and contrast assessment methods
- **WELL Building Standard** - Lighting Comfort features

Design teams should apply these benchmarks to ensure lighting is safe, comfortable and inclusive for all users.

**Table 86: Lighting at a Glance**

| <b>Feature / Element</b>          | <b>Minimum / Recommended Standard</b>   | <b>Key Notes / Accessibility Focus</b>  |
|-----------------------------------|---|---|
| <b>Illumination Consistency</b>   | <ul style="list-style-type: none"> <li>• Even light distribution throughout circulation areas</li> </ul>          | <ul style="list-style-type: none"> <li>• Avoid abrupt changes in brightness or color temperature</li> </ul> |
| <b>Glare &amp; Contrast</b>       | <ul style="list-style-type: none"> <li>• Minimize glare and reflective surfaces</li> </ul>                        | <ul style="list-style-type: none"> <li>• Use matte finishes and indirect lighting</li> </ul>                |
| <b>Exterior Lighting</b>          | <ul style="list-style-type: none"> <li>• <math>\geq 30</math> lux on routes and drop-off areas</li> </ul>         | <ul style="list-style-type: none"> <li>• Weather-resistant fixtures</li> <li>• Avoid shadows</li> </ul>     |
| <b>Interior Lighting</b>          | <ul style="list-style-type: none"> <li>• <math>\geq 50</math> lux on accessible paths</li> </ul>                  | <ul style="list-style-type: none"> <li>• Ensure uniform coverage and visual comfort</li> </ul>              |
| <b>Task Lighting</b>              | <ul style="list-style-type: none"> <li>• 200–500 lux depending on activity</li> </ul>                             | <ul style="list-style-type: none"> <li>• Provide adjustable fixtures for user needs</li> </ul>              |
| <b>Vertical Illumination</b>      | <ul style="list-style-type: none"> <li>• Required at communication and service points</li> </ul>                  | <ul style="list-style-type: none"> <li>• Supports lip reading, facial visibility, and safety</li> </ul>     |
| <b>Lighting Controls</b>          | <ul style="list-style-type: none"> <li>• Dimmable, user-adjustable, accessible placement (900–1200 mm)</li> </ul> | <ul style="list-style-type: none"> <li>• Support flexible use and energy efficiency</li> </ul>              |
| <b>Glazing &amp; Transparency</b> | <ul style="list-style-type: none"> <li>• Provide markings or contrast strips</li> </ul>                           | <ul style="list-style-type: none"> <li>• Prevent collisions and improve visibility</li> </ul>               |
| <b>Design Standards</b>           | <ul style="list-style-type: none"> <li>• IESNA, CSA B651, WELL, CIE</li> </ul>                                    | <ul style="list-style-type: none"> <li>• Follow professional lighting design best practices</li> </ul>      |



## 5.9 Signage and Wayfinding

### Rationale

Wayfinding and signage provide clear, consistent, and accessible guidance for all users, including individuals with mobility, vision, or cognitive limitations.

Effective signage promotes safety, independence and confidence when navigating public spaces, reducing confusion and supporting equitable access for all.

### Application

This section applies to all signage within City-owned or leased public facilities including:

- Buildings and facilities operated by the City
- Transit stations, terminals and platforms
- Parking facilities and garages
- Self-service or interactive kiosks and digital information systems

**Note:** Where possible, the same principles should extend to signage and wayfinding in public spaces such as parks, trails and exterior pathways.

### General Principles

- Apply universal design to ensure all users can perceive and understand information
- Present information in multiple modalities: visual, tactile and auditory
- Maintain consistency in terminology, colours, symbols and placement
- Use intuitive layouts and clear directional cues to minimize cognitive load
- Provide directional, regulatory, and informational signage where required
- Provide redundancy: reinforce messages across signs, tactile surfaces, floor markings and digital displays
- Offer maps, directories and digital wayfinding tools where appropriate to support navigation in complex environments

### Signage Design Requirements

#### Text and Typography

- Use clear, sans-serif fonts for maximum legibility
- Minimum character height: 16 mm for tactile signs, 40 mm for directional signs
- Minimum contrast ratio of 70% between text and background

- Use sentence case (first letter uppercase, remaining lowercase), for all room identification and directional signage to improve legibility for people with low vision
- All-uppercase may be used only for non-wayfinding applications, such as workstation nameplates, cubicle markers and internal labels not intended for independent navigation
  - Avoid all-uppercase text, as it reduces legibility for users with dyslexia or other learning disabilities
- This requirement aligns with CNIB Clear Print, ADA 703, and CSA B651 readability best practices

**Table 87: Character Height and Viewing Distance**

| <b>Minimum Character Height (mm)</b> | <b>Maximum Viewing Distance (mm)</b> |
|--------------------------------------|--------------------------------------|
| 200 mm                               | 6000 mm                              |
| 150 mm                               | 4600 mm                              |
| 100 mm                               | 2500 mm                              |
| 75 mm                                | 2300 mm                              |
| 50 mm                                | 1500 mm                              |
| 25 mm                                | 750 mm                               |

### **Tactile and Braille (interior signs only)**

- Required on all room identification, directional and safety signs
- Braille: Grade 2 standard
- Raised characters: 6 mm high, 1.5 mm minimum stroke width
- Mounting height: 900-1200 mm from finished floor to baseline of tactile characters

Tactile/Braille signage is required for permanent rooms and spaces that users may need to independently locate. Cubicle nameplates and non-permanent workstation signs are exempt.

### **Symbols and Pictograms**

- Use internationally recognized or City approved symbols (where feasible)
- Maintain minimum 70% contrast and minimum 150 mm symbol height
- Provide redundant text labels for clarity, where appropriate
- Include International Symbol of Accessibility (ISA) where applicable

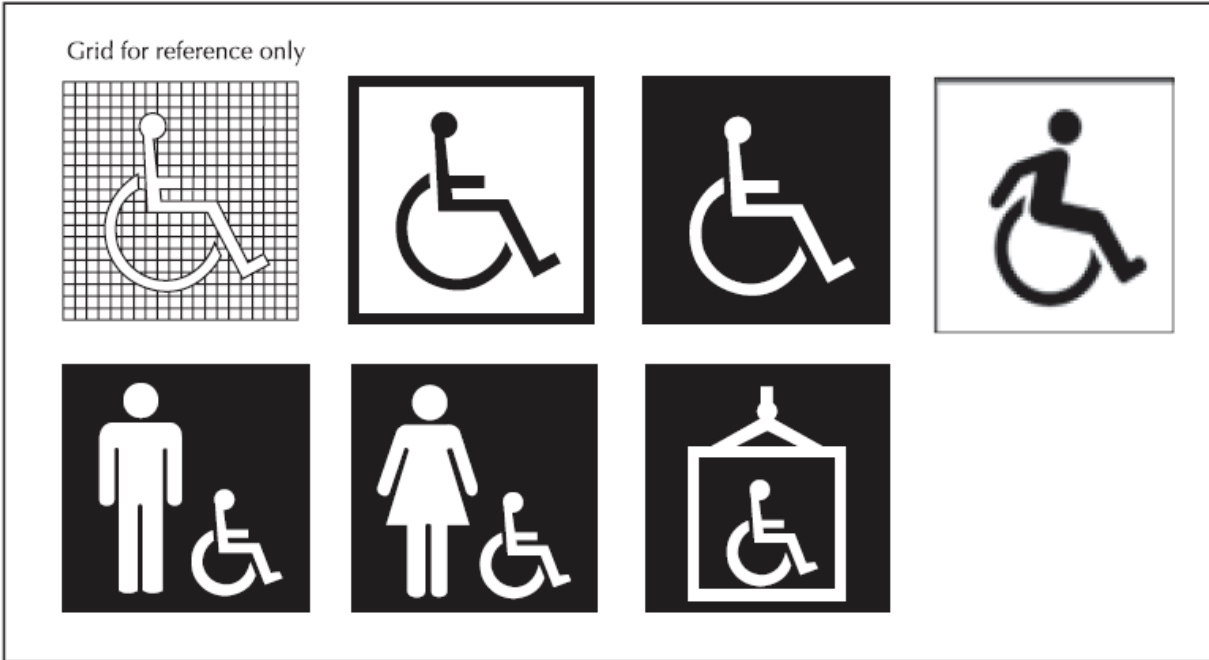

Figure 139: Wayfinding Principles – International Symbols of Accessibility

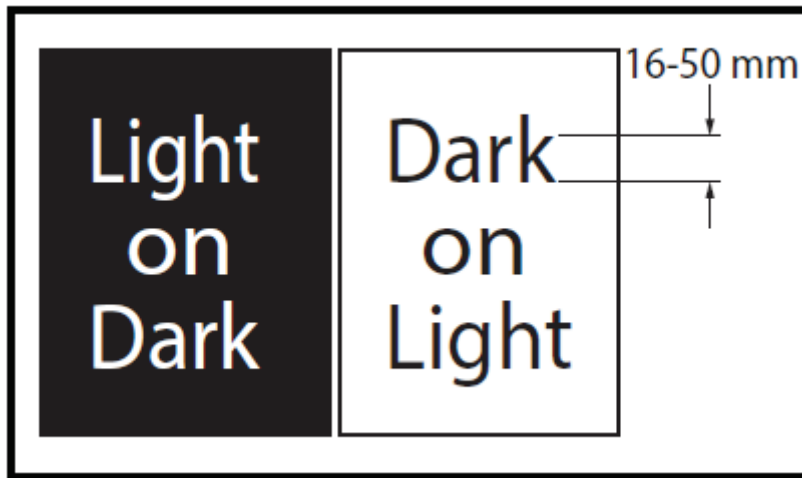
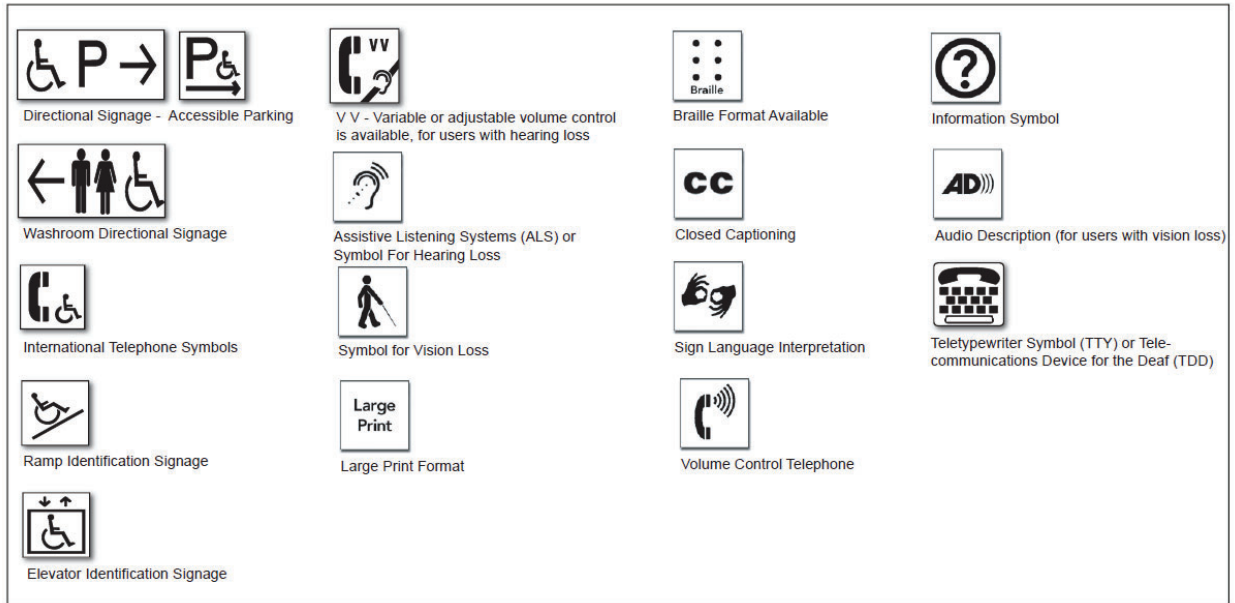

Figure 140: Colour Contrast on Signs



**Figure 141: Pictograms**

## Illumination

- Signs must be evenly lit without glare, where possible
- Use backlit or internally illuminated signs in low-light conditions
- Avoid reflections from glossy or metallic finishes

## Placement and Mounting

- Directional signage: 1200-1600 mm from floor to baseline of text
- Maintain clear floor space of 750 mm in front of signage
- Ensure signage is visible from main circulation paths and free of obstructions
- Avoid placing signs behind fixtures, doors or in areas prone to obstruction

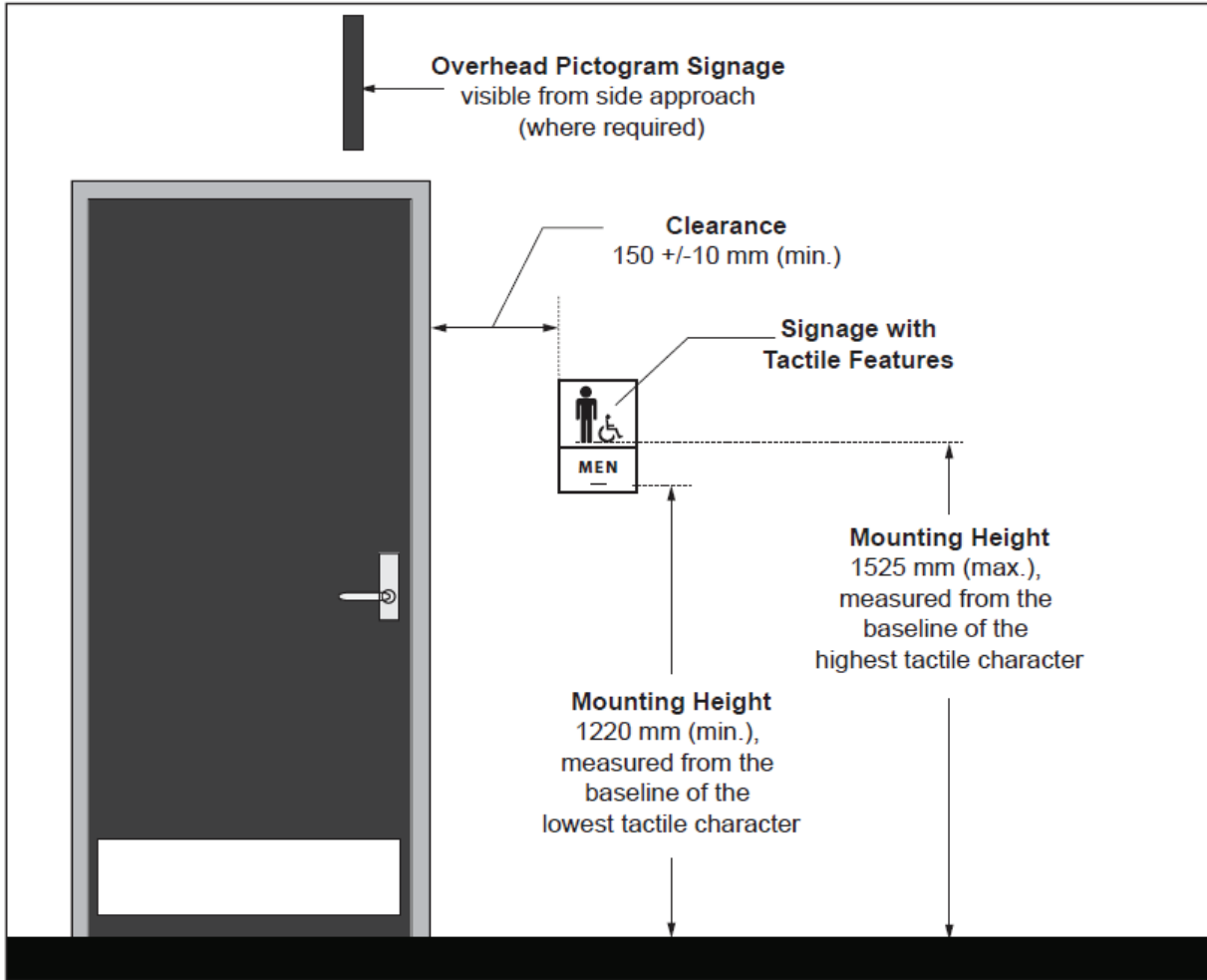

Figure 142: Mounting Location of Signage with Tactile Features

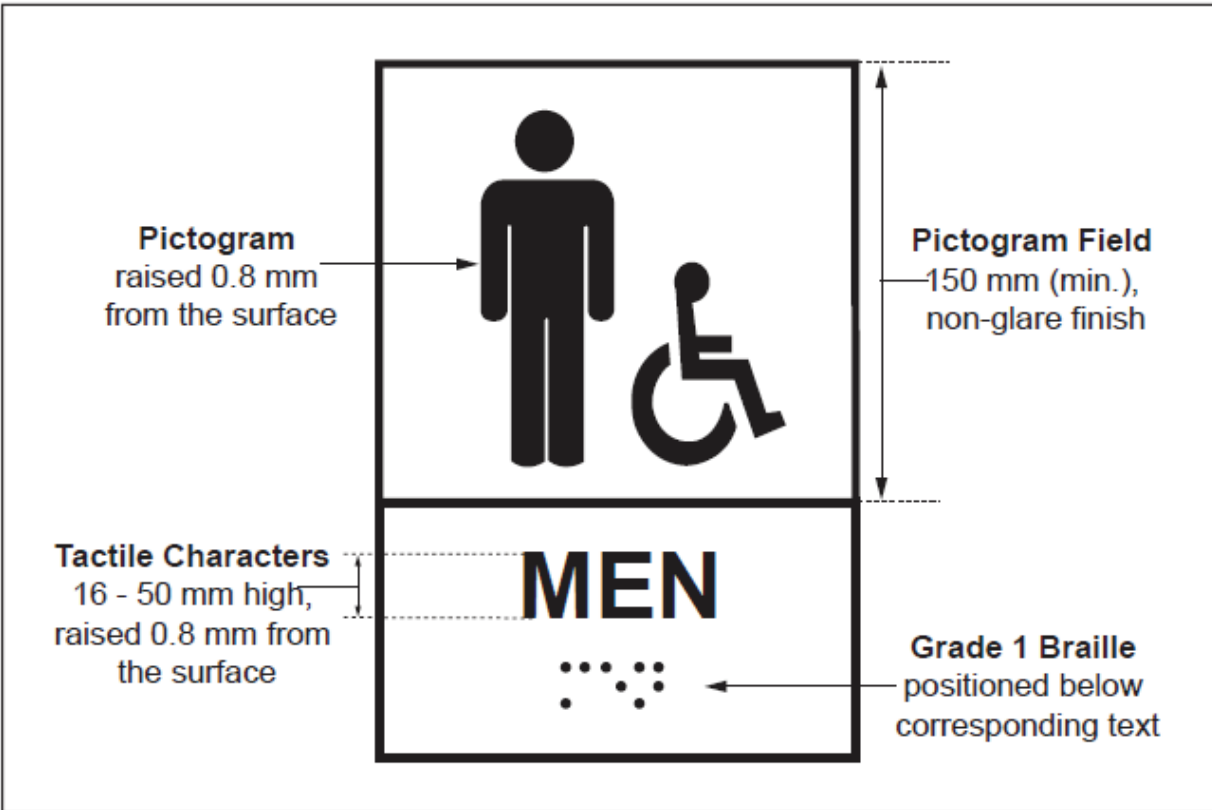

Figure 143: Signage with Tactile Features

## Wayfinding Strategy

### Zoning and Colour-Coding

- Assign distinct colour zones by floor or function
- Colours must meet minimum contrast ratio of 70% with surroundings

### Landmarks and Visual cues

- Integrate architectural features, murals or lighting to reinforce orientation, where possible
- Provide tactile paths or floor markings where appropriate for continuous guidance

### Auditory Guidance

- Provide audible cues in elevators, transit stations and large facilities
- Include auditory alerts for hazards, wayfinding or arrival notifications, where possible

### Digital and Interactive Signage

- Ensure touchscreen kiosks are usable from both seated and standing positions

- Provide auditory output, screen reader compatibility and step-by-step routing
- Where provided, include zoomable maps and high-contrast viewing modes

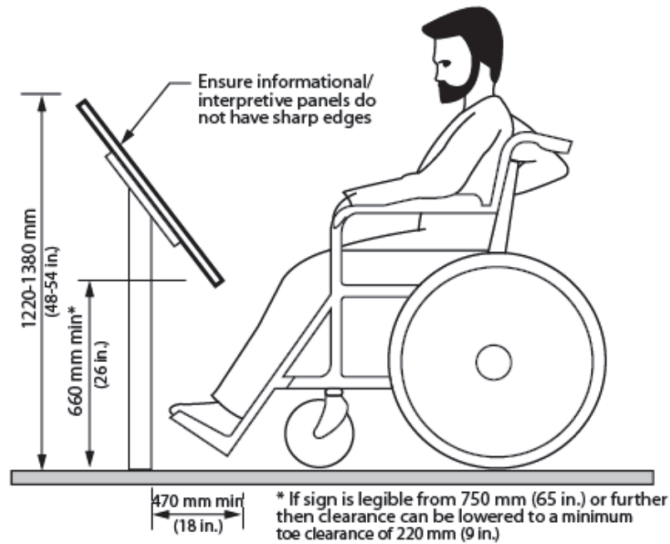

**Figure 144: Critical Dimensions for Information Systems and Displays**

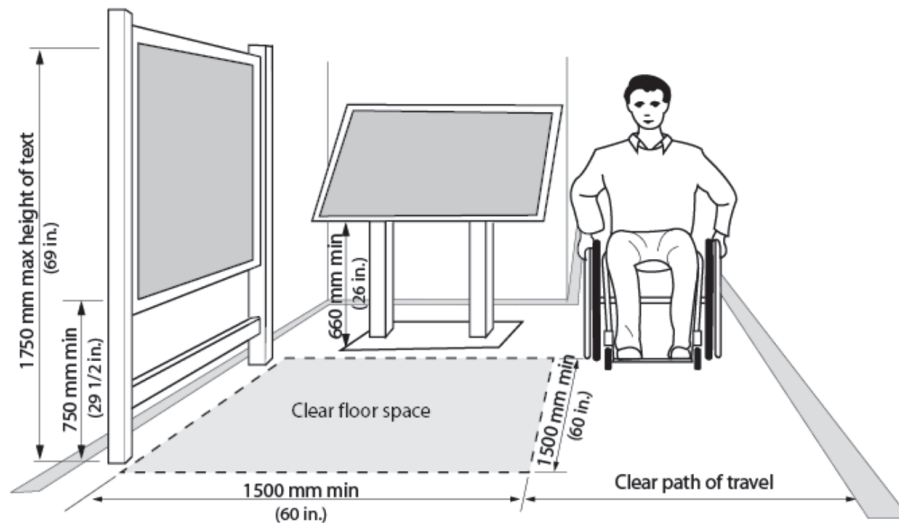

**Figure 145: Clear Space and Dimensions around Information Systems**

## Safety Integration

- Include signage for fire exits, emergency routes and assembly points
- Integrate floor slip-resistance markers where applicable for safe navigation

## Maintenance and Updates

- Inspect and maintain signage annually or after renovations
- Replace damaged, illegible or outdated signs promptly

- Maintain a centralized signage inventory with type, location and compliance details

**Table 88: Wayfinding & Signage Quick Reference Table**

| Sign Type                               | Primary Purpose                            | Text / Symbol Requirements   | Mounting / Height                  | Accessibility / Sensory Requirements                                  | Notes  |
|---|--|--|------------------------------------|---|--|
| <b>Room Identification</b>              | Identify rooms, offices, or amenities      | Raised text (6 mm), Grade 2 Braille, $\geq 16$ mm visual text, sans-serif font | 900–1200 mm                        | Tactile & Braille, high contrast, optional pictogram                  | Include international symbols where relevant                     |
| <b>Directional / Wayfinding</b>         | Guide circulation                          | $\geq 40$ mm text, high contrast, clear arrows                                 | 1200–1600 mm                       | Visual, optional tactile arrows, colour-coded zones                   | Visible from main circulation routes                             |
| <b>Informational / Regulatory</b>       | Provide rules, policies, or instructions   | $\geq 40$ mm text, clear layout  | 1200–1600 mm                       | Visual, optional pictogram  | Use consistent iconography                                       |
| <b>Safety / Emergency</b>               | Indicate exits, evacuation routes, hazards | $\geq 40$ mm text, standardized symbols  | 1200–1600 mm                       | Visual, tactile & Braille where critical; auditory alerts if feasible | Ensure visibility in low light                                   |
| <b>Elevator / Lift</b>                  | Identify floors and controls               | $\geq 16$ mm tactile, Grade 2 Braille, raised arrows                           | 900–1200 mm                        | Tactile and auditory floor announcements, high contrast               | Align with reach range standards                                 |
| <b>Restroom / Accessible Facilities</b> | Identify washrooms and stalls              | Raised text, Braille, pictograms   | 900–1200 mm                        | Tactile & Braille, high contrast, 750 mm clear space                  | Include gender-neutral or family-friendly signage where required |
| <b>Parking / Drop-off / Transit</b>     | Orientation and location                   | $\geq 150$ mm pictogram, high contrast   | Visible from vehicles or sidewalks | Visual; colour-coded zones  | Include tactile ground indicators where needed                   |
| <b>Digital / Interactive Kiosk</b>      | Digital navigation and information         | High contrast, scalable text, touch-friendly icons                             | 900–1200 mm                        | Audio output, screen-reader compatible, usable seated/standing        | Provide zoomable, step-by-step routing                           |

| Sign Type                      | Primary Purpose               | Text / Symbol Requirements                 | Mounting / Height        | Accessibility / Sensory Requirements | Notes                              |
|--------------------------------|-------------------------------|--|--------------------------|--------------------------------------|------------------------------------|
| <b>Floor / Path Indicators</b> | Guide circulation along route | Contrasting tactile strips, slip-resistant | Aligned with travel path | Tactile & visual contrast            | Use in complex or large facilities |

## Notes / Implementation Tips

- **Contrast ratio:** Minimum 70% for all visual signage
- **Consistency:** Apply uniform colors, symbols, fonts across the facility
- **Redundancy:** Reinforce information through multiple modalities (signs, tactile surfaces, floor patterns and landmarks)
- **Auditory:** Provide voice or tone announcements where possible in large or complex spaces
- **Maintenance:** Inspect and replace damaged or outdated signs annually
- **Documentation:** Maintain an updated signage inventory including type, location and compliance features

### Technical Note – Signage and Wayfinding Standards

For detailed design and performance requirements, refer to:

- **CSA B651** – Accessible Design for the Built Environment
- **ISO 21542** – Building Construction – Accessibility and Usability
- \*CNIB Clear Print and Wayfinding Guidelines
- **WELL Building Standard** – Mind & Movement categories

Design teams should involve accessibility specialists and wayfinding consultants early in design to ensure systems are clear, intuitive and inclusive for all users.

# Pictogram Examples

## Facility Signage Pictograms



Figure 146: Facility Pictograms



Figure 147: Park Pictograms

## 5.10 Self-service Kiosks

### Rationale

Self-service technologies, including kiosks, vending machines, and ticketing machines, increasingly replace in-person interaction. To ensure equitable access, these systems must be designed so all users — regardless of mobility, vision, hearing, strength, or dexterity — can approach, understand and operate them safely and independently.

### Application

This section applies to:

- Vending and ticketing machines
- Information and transaction kiosks with touchscreens or keypads
- Other self-service terminals for communication, commerce, entertainment, or education

All devices accessible to the public must meet the requirements of this section.

### Design Requirements

#### Location and Access

- Machines must be located along accessible routes without obstructing circulation paths, in accordance with Section 3.3 Interior Accessible Routes
- Provide clear sightlines and consistent placement within facilities for predictable navigation

#### Clear Floor Space

- Provide unobstructed, level floor space in front of machines
- Front approach: minimum 900 mm wide × 1500 mm long
- Side approach: minimum 900 mm wide × 2200 mm long
- Floor space must meet the requirements of Section 2.1 Space and Reach Requirements

#### Reach and Operable Parts

- Front approach:
  - Controls and interactive elements must be placed 460 mm to 1050 mm above finished floor (A.F.F.)
- Side approach:
  - Controls must be placed 860 mm to 1050 mm A.F.F.

- Maximum forward reach: 500 mm
- Provide knee and toe clearance:
  - Height: min. 735 mm
  - Depth: 600 mm
  - Width: 900 mm
- Controls must be operable with one hand, without tight grasping, pinching or twisting

### **Controls and Feedback**

- Provide multimodal feedback:
  - Visual: high-contrast text and symbols, minimum 70% contrast
  - Auditory: voice guidance, volume controls, headphone jack for privacy
  - Tactile: Braille and raised characters, vibro-tactile feedback (haptic technology) where feasible
- On-screen text must be resizable and use sans-serif fonts
- Lighting must avoid glare and shadows on displays
- Controls must comply with Section 5.1 Controls and Operating Mechanisms

### **Integration with Wayfinding**

- Kiosk interfaces must align with the facility's overall wayfinding system
- Provide signage in highly contrasting characters, minimum 13 mm in height
- Provide tactile maps, consistent icons and auditory prompts where applicable
- Signage must comply with Section 5.9 Signage and Wayfinding

### **Privacy and Security**

- Provide options for private audio output, where possible
- Ensure input devices (e.g., keypads) are angled or shielded from side view to protect user information, where possible

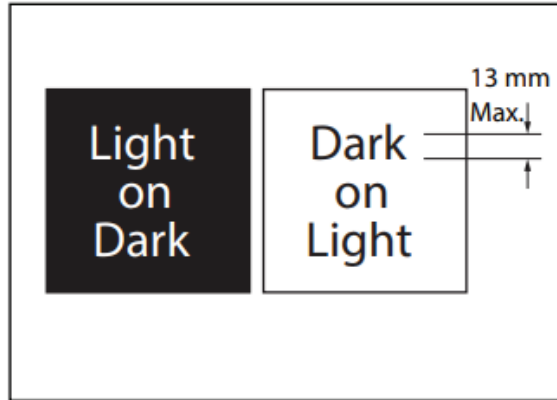

Figure 148: Signage

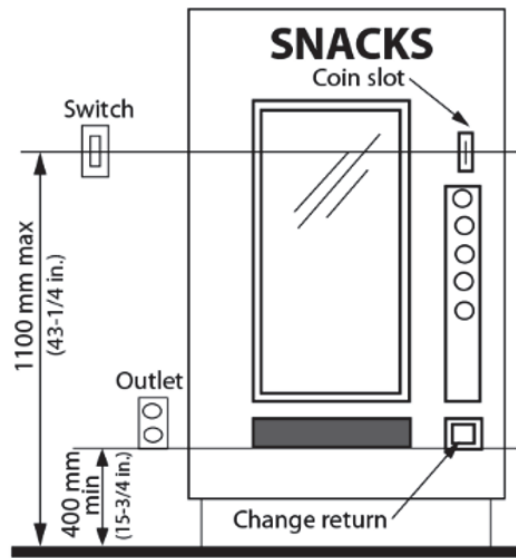

Figure 149: Vending Machine

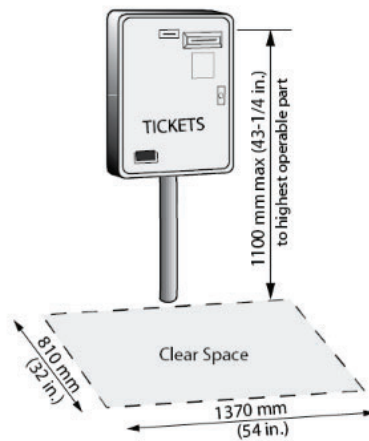

Figure 150: Ticket Dispensing Machine

## Technical Note – Self-Service Technology Standards

While this standard outlines accessibility outcomes, the detailed design and performance of self-service kiosks, ticketing machines, and vending devices must follow recognized accessibility and technology standards. These include:

- **CSA B651 – Accessible Design for the Built Environment** (reach, operability, force, and clear floor space)
- **ISO 9241-210 – Human-centred Design for Interactive Systems** (usability and interface accessibility)
- **EN 301 549 – Accessibility Requirements for ICT Products and Services** (digital accessibility and interoperability)
- **WCAG 2.2 – Web Content Accessibility Guidelines** (visual, auditory, and tactile interface criteria)

Design teams should apply these standards when selecting or specifying self-service technologies to ensure consistent accessibility, usability, and compliance across all facilities.

### Cross-Reference Note

Self-service kiosks and automated machines must be designed in coordination with related accessibility features. See:

- **Section 2.1 – Space and Reach Requirements** for approach dimensions
- **Section 5.1 – Controls and Operating Mechanisms** for reach ranges, operability, and force requirements
- **Section 5.9 – Signage and Wayfinding** for interface accessibility, tactile labelling, and visual contrast standards

**Table 89: Self-service Kiosks at a Glance**

| Element                      | Minimum / Recommended Dimensions  | Key Accessibility Requirements   |
|------------------------------|---|--|
| <b>Location &amp; Access</b> | <ul style="list-style-type: none"> <li>• Along accessible route</li> </ul>                              | <ul style="list-style-type: none"> <li>• Must not obstruct circulation</li> <li>• Consistent placement and sightlines</li> </ul> |
| <b>Clear Floor Space</b>     | <ul style="list-style-type: none"> <li>• Front: 900 × 1500 mm</li> <li>• Side: 900 × 2200 mm</li> </ul> | <ul style="list-style-type: none"> <li>• Firm, level surface</li> <li>• Clear of obstacles</li> </ul>                            |
| <b>Reach Range (Front)</b>   | <ul style="list-style-type: none"> <li>• 460–1050 mm A.F.F.</li> </ul>                                  | <ul style="list-style-type: none"> <li>• Controls operable with one hand, no tight grasping/pinching</li> </ul>                  |

| Element                       | Minimum / Recommended Dimensions  | Key Accessibility Requirements  |
|-------------------------------|---|---|
| <b>Reach Range (Side)</b>     | <ul style="list-style-type: none"> <li>860–1050 mm A.F.F.</li> </ul>                        | <ul style="list-style-type: none"> <li>Maintain 500 mm max forward reach</li> </ul>   |
| <b>Knee / Toe Clearance</b>   | <ul style="list-style-type: none"> <li>Height 735 mm, Depth 600 mm, Width 900 mm</li> </ul> | <ul style="list-style-type: none"> <li>Required for seated users</li> </ul>   |
| <b>Feedback Modes</b>         | <ul style="list-style-type: none"> <li>Visual, tactile, auditory</li> </ul>                 | <ul style="list-style-type: none"> <li>≥70% contrast, Braille, voice guidance, headphone jack, haptic feedback</li> </ul>       |
| <b>Lighting &amp; Glare</b>   | <ul style="list-style-type: none"> <li>Even, glare-free illumination</li> </ul>             | <ul style="list-style-type: none"> <li>Avoid shadows or reflections on screens</li> </ul>                                       |
| <b>Wayfinding Integration</b> | <ul style="list-style-type: none"> <li>Consistent signage, icons, tactile maps</li> </ul>   | <ul style="list-style-type: none"> <li>Comply with Section 5.9 Signage and Wayfinding</li> </ul>                                |
| <b>Privacy &amp; Security</b> | <ul style="list-style-type: none"> <li>Shielded input, private audio</li> </ul>             | <ul style="list-style-type: none"> <li>Protects user data</li> <li>Complies with accessibility and safety principles</li> </ul> |

## 6.1 Offices, Work Areas and Meeting Rooms

### Rationale

Ensure offices, work areas, and meeting rooms are accessible for all public users and staff, accommodating a wide range of mobility, vision, and hearing abilities.

### Application

Applies to offices, work areas, and meeting rooms used by the public, clients, or staff. Where multiple workstations are provided, at least 5% (minimum 1) shall have height-adjustable surfaces.

### Key Principles

- **Inclusive design:** Adjustable furniture, work surfaces, and meeting facilities
- **Acoustics and communication:** Minimize noise, provide assistive listening, and support effective voice communication
- **Lighting and visual access:** Provide consistent, glare-free task and ambient lighting to support reading, facial visibility and sign-language interpretation
- **Clear circulation:** Accessible routes and turning spaces for mobility devices
- **Signage and wayfinding:** Directional signage for entrances, rooms, and accessible routes

### Requirements

#### Workspaces

- Minimum 5% of workstations must be height-adjustable
- Located on accessible routes complying with Section 3.3 Interior Accessible Routes
- Doors must meet the criteria in Section 3.2 Doors and Doorways
- Ensure aisle space throughout circulation areas is 1100 mm wide, minimum
- Provide clear floor space for 180° wheelchair/scooter turning per Section 2.1 Space and Reach Requirements
- Knee clearances under work surfaces comply with 2.10 Seating, Tables and Work Surfaces
- Provide assistive listening systems in meeting rooms and boardrooms equipped with audio amplification

## Meeting and Conference Rooms

- Include signage and wayfinding systems that meet the criteria in Section 5.9 Signage and Wayfinding
- Provide interior accessible paths that include:
  - Clear aisle: minimum 1100 mm wide
  - Turning space: minimum of 1675 mm diameter (large rooms), minimum 2500 mm diameter (when there are more than 50 participants)
- When provided buffet counters and tables, provide two heights for seated and standing users
- Accessible toilets: adequate number and locations near conference rooms
- Hearing enhancement provisions for all conference areas
- Temporary signage follows permanent signage standards
- Speaker podiums/tables fully accessible
- Switches, sockets, and presentation controls installed at accessible height

## Office Buildings – Additional Requirements

- Circulation aisles: Minimum 1100 mm wide
- Doors: clear width 860 mm minimum
- Floor space in front of office equipment  $\geq 1700 \text{ mm} \times 1700 \text{ mm}$
- Staff areas (canteens, kitchens, offices, meeting rooms) accessible
- Meeting room equipment usable by all participants
- Accessible workstations in public areas:
  - Entry width  $\geq 860 \text{ mm}$
  - Clear floor space  $\geq 1700 \text{ mm} \times 1700 \text{ mm}$
  - Cabinet/storage controls  $\leq 1100 \text{ mm}$  high
  - Forward approach:  $915 \text{ mm} \times 1370 \text{ mm}$ ; side approach:  $1525 \text{ mm} \times 915 \text{ mm}$
  - Work surface height:  $\leq 860 \text{ mm}$
  - Knee and toe space (front approach):  $735 \text{ mm}$  high  $\times 500 \text{ mm}$  deep  $\times 900 \text{ mm}$  wide
- Adjustable general and task lighting
- Security systems: accessible, maneuverable, and operable by all employees

## Cross-Reference Note

Office and meeting spaces must be designed in coordination with related accessibility features. See:

- **Section 2.1 – Space and Reach Requirements** for clearances
- **Section 3.3 – Interior Access Routes** for circulation
- **Section 5.1 – Controls and Operating Mechanisms** for reachable switches and outlets

## Technical Note – Workplace Accessibility and Inclusive Design Standards

Detailed workstation and meeting-room accessibility parameters should align with:

- **CSA B651** – Accessible Design for the Built Environment
- **ISO 21542** – Building Construction – Accessibility and Usability of the Built Environment
- **WELL Building Standard v2** – Comfort and Ergonomics concepts
- **LEED v4/v5 EQ Credit: Interior Lighting and Acoustic Performance**

Design teams should engage accessibility consultants and interior designers to ensure physical layouts, lighting, acoustics, and furnishings meet both accessibility and wellness goals.

**Table 90: Offices, Work Areas and Meeting Rooms – at a Glance**

| Feature / Element         | Minimum / Recommended Dimensions  | Notes / Key Requirements  |
|---------------------------|---|---|
| <b>Workstations</b>       | <ul style="list-style-type: none"> <li>• ≥ 5 % (min 1) height-adjustable</li> </ul> | <ul style="list-style-type: none"> <li>• Located on accessible routes</li> <li>• Include clear floor space for 180° turn (see 2.1 Space and Reach)</li> </ul> |
| <b>Circulation Aisles</b> | <ul style="list-style-type: none"> <li>• 1100 mm min width</li> </ul>               | <ul style="list-style-type: none"> <li>• Continuous accessible path to all desks, equipment, and exits</li> </ul>   |
| <b>Doors</b>              | <ul style="list-style-type: none"> <li>• 860 mm min clear width</li> </ul>          | <ul style="list-style-type: none"> <li>• Hardware operable with one hand</li> <li>• Lever or push-type handles</li> </ul>                                     |
| <b>Turning Space</b>      | <ul style="list-style-type: none"> <li>• 1700 mm diameter (general)</li> </ul>      | <ul style="list-style-type: none"> <li>• Allows wheelchair/scooter turning within meeting spaces</li> </ul>   |

| Feature / Element                | Minimum / Recommended Dimensions   | Notes / Key Requirements  |
|----------------------------------|--|---|
|                                  | <ul style="list-style-type: none"> <li>• 2500 mm preferred for large rooms</li> </ul>          |   |
| <b>Knee / Toe Clearance</b>      | <ul style="list-style-type: none"> <li>• 735 mm high × 500 mm deep × 900 mm wide</li> </ul>    | <ul style="list-style-type: none"> <li>• Required at work surfaces and podiums</li> </ul>   |
| <b>Work Surface Height</b>       | <ul style="list-style-type: none"> <li>• Adjustable range 650–860 mm</li> </ul>                | <ul style="list-style-type: none"> <li>• For seated / standing users</li> <li>• Clear approach 915 × 1370 mm (front) or 1525 × 915 mm (side)</li> </ul> |
| <b>Lighting</b>                  | <ul style="list-style-type: none"> <li>• Per Section 5.8 Lighting</li> </ul>                   | <ul style="list-style-type: none"> <li>• Even, glare-free illumination</li> <li>• Adjustable task lighting preferred</li> </ul>                         |
| <b>Acoustics / Communication</b> | <ul style="list-style-type: none"> <li>• N/A</li> </ul>  | <ul style="list-style-type: none"> <li>• Minimize noise</li> <li>• Provide assistive listening in amplified spaces</li> </ul>                           |
| <b>Signage / Wayfinding</b>      | <ul style="list-style-type: none"> <li>• Per Section 5.9</li> </ul>                            | <ul style="list-style-type: none"> <li>• Include tactile/visual room ID and directional signage</li> </ul>  |
| <b>Security / Controls</b>       | <ul style="list-style-type: none"> <li>• 900–1200 mm AFF</li> </ul>                            | <ul style="list-style-type: none"> <li>• Accessible switches, card readers, and door hardware</li> </ul>  |
| <b>Furniture / Storage</b>       | <ul style="list-style-type: none"> <li>• Controls ≤ 1100 mm high</li> </ul>                    | <ul style="list-style-type: none"> <li>• Stable, reachable from seated and standing positions</li> </ul>  |
| <b>Buffet / Counter Surfaces</b> | <ul style="list-style-type: none"> <li>• Two heights (750 mm and 1000 mm preferred)</li> </ul> | <ul style="list-style-type: none"> <li>• For seated and standing users at food or service areas</li> </ul>  |
| <b>Meeting Technology</b>        | <ul style="list-style-type: none"> <li>• N/A</li> </ul>  | <ul style="list-style-type: none"> <li>• Accessible podiums</li> <li>• Controls and outlets within reach range</li> </ul>                               |
| <b>Restrooms (Proximity)</b>     | <ul style="list-style-type: none"> <li>• Adjacent or same floor</li> </ul>                     | <ul style="list-style-type: none"> <li>• Provide accessible washroom per 3.7 Washrooms</li> </ul>   |

## 6.2 Recreational and Community Facilities

### Rationale

Recreation, leisure, and active sports opportunities should be accessible to all community members. This includes ensuring equitable access to recreational and community facilities, covering all areas such as the site, activity spaces, gymnasiums, fitness centres, locker and change rooms and showers.

People with disabilities should be able to actively participate, whether as athletes, spectators, volunteers, or staff.

Waiting and viewing areas should include benches or designated seating for individuals who may have difficulty standing for long periods.

### Application

This section applies to recreational and community facilities operated or leased by the City, including arenas, ice rinks, gymnasiums, fitness centres, swimming pools, therapeutic pools, and public spas.

All such facilities must:

- Comply with the general accessibility requirements outlined throughout Sections 1–5 of this manual
- Provide accessible routes to, from, and within all activity, spectator, and amenity areas
- Incorporate inclusive features for both participants and spectators
- Where possible, integrate assistive technologies (e.g., public address systems, listening systems, or tactile wayfinding) to support communication and orientation

Specialized design considerations for ice rinks, sledge hockey, and aquatic facilities are provided below.

### General Requirements

Recreational and community facilities must:

#### Seating

- Provide accessible seating options are available as per section 2.10

- Where seating is accessed by stairs, provide detectable warning surfaces as per section 2.8

### **Accessible Routes**

- Provide an accessible route per section 3.3 to the arena, gymnasium or ice surface
- Access panels or gates must have a minimum clear width of 950 mm

### **Performance and Event Spaces**

- Provide direct accessible routes from entrances and lobbies to stages, dressing rooms, washrooms and other performer spaces

### **Lockers and Shelving**

- Comply with sections 3.9 and 16.4 Lockers and Baggage Storage

### **Coat Hooks**

- At least 10% (minimum one) must be mounted within the reach range specified in Section 2.1 Space and Reach Requirements

### **Public Address and Information Systems**

- Where possible, integrate PA systems with visual information screens to support users who are deaf or hard of hearing

### **Service Animal Relief Stations**

- Where feasible, provide accessible relief areas for service animals
- These areas should:
  - Allow quick and easy access to a safe, well-maintained space, such as along an accessible path of travel
  - Be integrated into landscape design
  - Have waste receptacles nearby
  - Have signage that identifies the designated area

### **Ice Rinks**

Ice rinks should be designed for multiple recreational and competitive uses, such as skating, hockey, sledge hockey and more. New or redeveloped ice pads should be designed to enable safe, independent access for all users. Existing rinks should incorporate accessibility improvements where feasible.

### **Access Points**

- Provide at least one access point (in addition to the resurfacer's gate) for entry to the ice surface

- The access point must meet the following criteria:
  - A minimum clear width of 2100 mm if using a single overhead gate.
  - A minimum clear width of 3600 mm if using a single swing gate.
  - Must accommodate ice resurfacers (Zamboni machines)

#### **Accessible Entrance to Ice Surface**

- Provide at least one accessible entrance/gate (minimum 860 mm clear width) in new or reconstructed ice pads
  - For existing facilities, integrate accessibility improvements wherever technically feasible
- Ensure level or beveled transition (max slope 1:2) between the ice pad and arena floor

#### **Automated External Defibrillator (AED)**

- Provide an AED on-site in a visible, accessible location

### **Optional Design Considerations - sledge hockey**

To accommodate sledge hockey or similar para-sport activities, arenas may include additional design features. These are not required but are recommended where facilities intend to host adaptive sports.

#### **Player Benches and Penalty Areas**

- Provide Plexiglas fronts for visibility from seated sledges
- Include two level-access doors per bench for direct entry to the ice
- Maintain level, ice or plastic flooring in benches and penalty boxes to avoid blade damage
- Ensure no protruding supports; pad or shield structural elements

#### **Removable or Adjustable Benches**

- Design benches to be removable or have at least 900 mm clearance behind the boards

#### **Accessible Player Boxes:**

- Use removable boards or low-threshold Plexiglas sections for easy entry

#### **Surfaces Between Ice and Player Areas:**

- Use durable, slip-resistant artificial surfaces with proper maintenance and sanitation

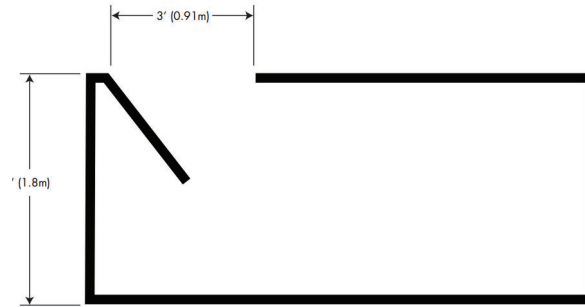

Figure 151: Player Area

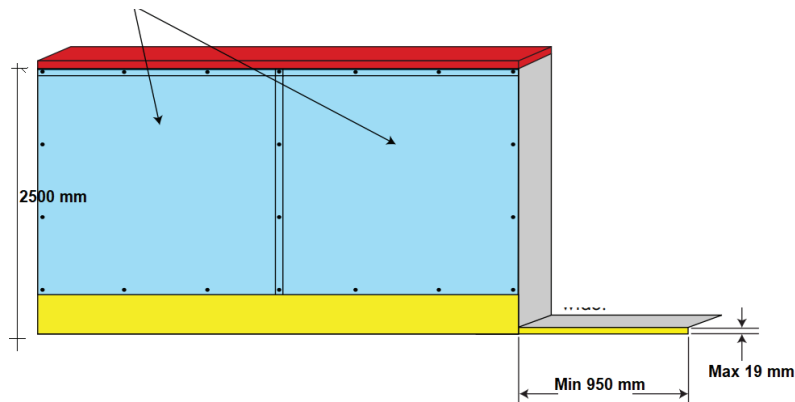

Figure 152: Player Area

## Swimming Pools, Therapeutic Pools/Public Spas

Swimming and aquatic therapy are vital recreational and wellness activities for many people with disabilities.

Design should prioritize independent, dignified entry and clear wayfinding around wet areas.

### Accessible Path of Travel

- Provide direct accessible routes (per section 3.3 Interior Accessible Routes) from the entrances to change rooms and from change rooms to pool deck
- The pool deck must be a minimum of 1800 mm wide with a clear accessible route around the entire perimeter

### Pool Ramps

- Provide handrails on both sides of the ramp, between 865 and 965 mm high
- Ramp width: minimum 1100 mm
- Provide edge protection, slip-resistant surfaces and proper drainage
- If the ramp is not submerged:
  - Include a landing at the bottom of the ramp that is 450 to 550 mm below the top of the wall

- Install a floor drain at the lowest point of the ramp
- Ensure a width of 250 to 300 mm between the pool and the ramp at the top
- Mark the water depth at the landing with figures at least 100 mm high
- Ensure a maximum slope of 1:12 and provide a 1500 mm x 1500 mm minimum landing
- If the ramp is submerged:
  - Maintain a water depth of 600 to 900 mm at the bottom
  - Provide a hard-surfaced area at least 750 mm wide adjacent to the entire length of the submerged ramp
  - Use contrasting finishes for safety

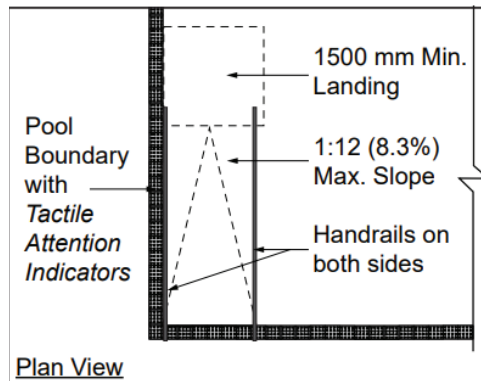

**Figure 153: Ramp at Pool**

## Pool Steps

- Mark risers and treads with 50 mm contrasting strips
- Provide color-contrasting handrails on both sides of the steps, extending at least 300 mm beyond the pool edge

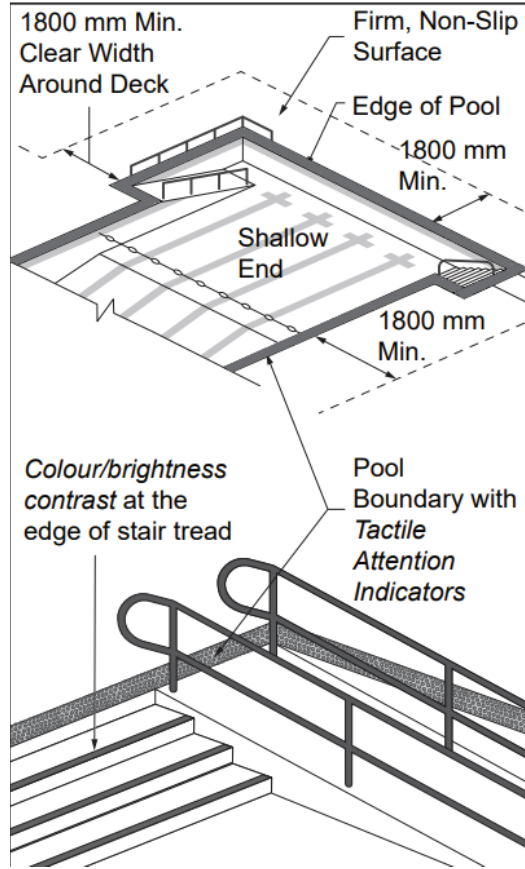
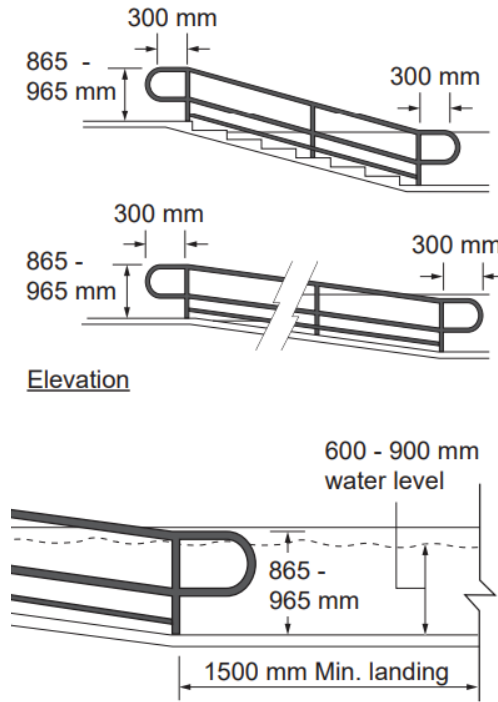

Figure 154: Pool Deck and Perimeter Areas

Handrails at Pool Stairs and Ramps



**Figure 155: Handrails at Pool**

**Pool Lifts**

- Pool lifts must be positioned so that the water level does not exceed 1220 mm, unless the entire pool depth is more than 1220 mm
- The seat centerline should be at least 400 mm from the pool edge when raised
- Provide a clear space beside the seat (opposite the water) that is at least 915 mm wide and extending forward no less than 1220 mm
- Must be operable from both the deck or water
- The lift must have a weight capacity of at least 135 kg (300 lbs)

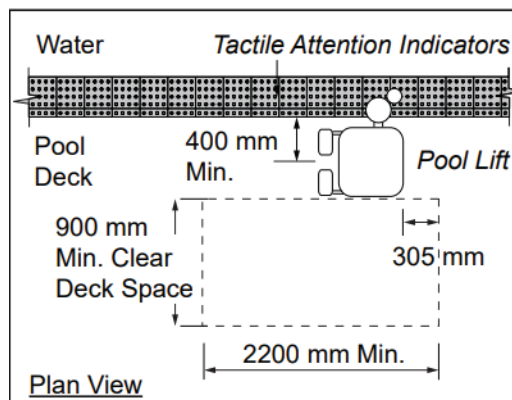

**Figure 156: Pool Lift on Deck**

## Pool Deck and Surfaces

- Use firm, slip-resistant, non-abrasive materials
- If a curbed edge is provided, it should be between 200 mm to 400 mm high
- Clear colour and texture contrast at edges and hazards
- Adequate drainage for all deck areas

## Tactile Indicators

- Where possible, provide tactile demarcation along pool edges and key routes from change rooms and amenities

## Therapeutic Pools

- Depth for exercise portion of therapy pool must be between 1050 mm and 1200 mm
- Submerged benches must comply with Section 2.11 Seating, Tables and Work Surfaces
- Underwater exercise bars are recommended

## Public Spas

- Minimum clear space of 1800 mm at main entrance and 900 mm on all other sides
- For smaller spas with less than 6 m<sup>2</sup> of area and a maximum dimension of 2500 mm, one section of the pool deck may have a minimum clear space of 300 mm
- If steps are provided for entry and egress, they must:
  - Include handrails
  - Have a non-slip surface
  - Have a color-contrasting band along the step's side and top edge
- Slope should not exceed 1:12
- Maximum seat or bench depth should be 600 mm

## Transfer Walls for Spas

- The transfer wall should meet the following specifications:
  - Height: 405 mm to 485 mm above deck
  - Depth: 300 mm to 400 mm
  - One grab bar perpendicular to the wall, 100-150 mm above top surface
- Clear transfer space of 900 mm x 2200 mm adjacent

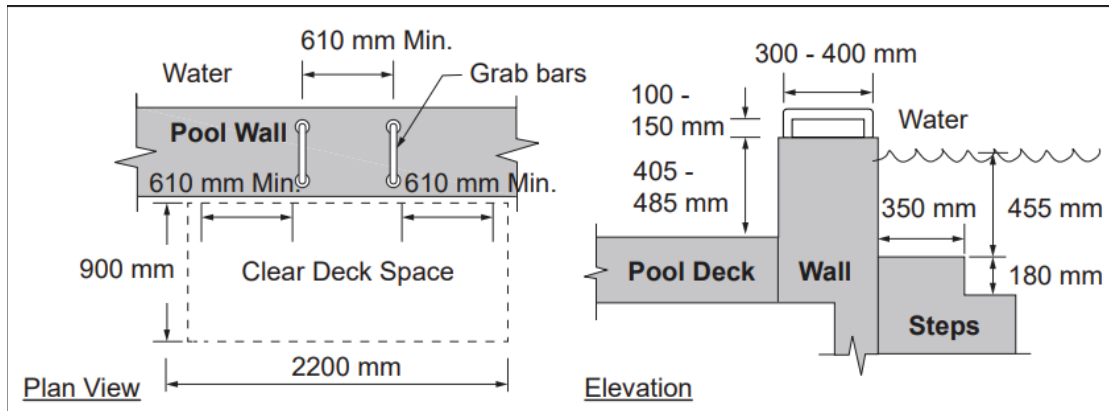
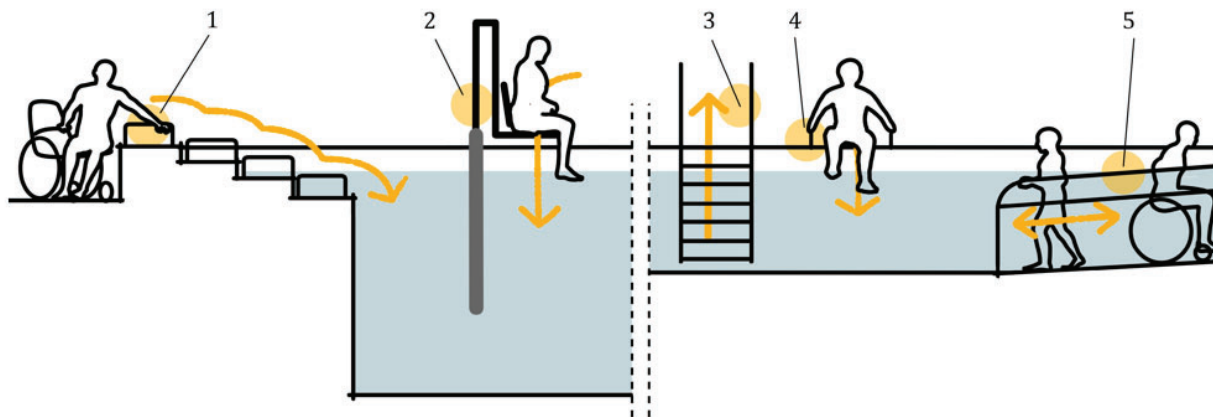

Figure 157: Transfer Wall with Steps



### Key

1. Access steps
2. Pool lift
3. Access stair
4. Transfer wall
5. Ramp

Figure 158: Examples of different types of pool access

## Technical Note – Accessible Recreation and Aquatic Design Standards

While this standard establishes accessibility and inclusion outcomes, detailed technical performance requirements for recreational and aquatic facilities should be developed by qualified designers in accordance with recognized industry standards, including:

- **CSA B651** – Accessible Design for the Built Environment
- **ISO 21542** – Building Construction – Accessibility and Usability of the Built Environment

- **IACS Guidelines** – International Association for Sports and Leisure Facilities (barrier-free sports facility design)
- **OBC / NBC** – Requirements for exits, guard heights, and aquatic safety features
- **LEED / WELL Building Standard** – Acoustic, lighting, and comfort provisions for public wellness environments

Design teams should apply these standards in collaboration with accessibility specialists, recreation planners, and facility operators to ensure environments are safe, inclusive, and functional for all participants, spectators, and staff.

**Table 91: Recreational Facilities – at a Glance**

| Feature / Element                        | Minimum / Recommended Dimensions   | Notes / Key Requirements   |
|--|--|--|
| <b>Seating</b>                           | <ul style="list-style-type: none"> <li>• Per Section 2.10</li> </ul>                         | <ul style="list-style-type: none"> <li>• Provide accessible seating for participants and spectators</li> <li>• Detectable warning surfaces where accessed by stairs (Section 2.8)</li> </ul> |
| <b>Accessible Routes</b>                 | <ul style="list-style-type: none"> <li>• 950 mm min clear width at gates / panels</li> </ul> | <ul style="list-style-type: none"> <li>• Continuous accessible route to arena, gymnasium, or ice surface (Section 3.3)</li> </ul>  |
| <b>Performance &amp; Event Spaces</b>    | <ul style="list-style-type: none"> <li>• N/A</li> </ul>                                      | <ul style="list-style-type: none"> <li>• Direct accessible route from lobby/entrance to stages, dressing rooms, washrooms, and performer areas</li> </ul>                                    |
| <b>Lockers &amp; Shelving</b>            | <ul style="list-style-type: none"> <li>• Per Sections 3.9 and 16.4</li> </ul>                | <ul style="list-style-type: none"> <li>• Accessible height and reach</li> <li>• At least 10 % coat hooks within reach range (Section 2.1)</li> </ul>   |
| <b>Public Address &amp; Info Systems</b> | <ul style="list-style-type: none"> <li>• N/A</li> </ul>                                      | <ul style="list-style-type: none"> <li>• Combine audible and visual systems to support users who are deaf or hard of hearing</li> </ul>  |
| <b>Service Animal Relief Stations</b>    | <ul style="list-style-type: none"> <li>• N/A</li> </ul>                                      | <ul style="list-style-type: none"> <li>• Provide accessible, signed, well-drained relief areas connected to accessible routes</li> </ul>   |

| Feature / Element                         | Minimum / Recommended Dimensions   | Notes / Key Requirements  |
|---|--|---|
| <b>Ice Rink Access Points</b>             | <ul style="list-style-type: none"> <li>• 2100 mm (overhead gate) / 3600 mm (swing gate)</li> </ul>                                 | <ul style="list-style-type: none"> <li>• Provide at least one additional access point beyond resurfacers gate</li> <li>• Accommodate Zamboni access</li> </ul>                      |
| <b>Accessible Entrance to Ice Surface</b> | <ul style="list-style-type: none"> <li>• <math>\geq 860</math> mm clear width</li> </ul>   | <ul style="list-style-type: none"> <li>• Provide level or beveled transition (max 1:2 slope) between ice and arena floor</li> </ul>   |
| <b>AED</b>                                | <ul style="list-style-type: none"> <li>• N/A</li> </ul>  | <ul style="list-style-type: none"> <li>• Provide visible, accessible automated external defibrillator on-site</li> </ul>  |
| <b>Sledge Hockey – Optional Features</b>  | <ul style="list-style-type: none"> <li>• Various clearances / 900 mm behind boards</li> </ul>                                      | <ul style="list-style-type: none"> <li>• Plexiglas fronts for benches / boxes, level-access doors, non-abrasive flooring, removable benches, extended ice sheet optional</li> </ul> |
| <b>Pool Deck</b>                          | <ul style="list-style-type: none"> <li>• 1800 mm min clear route</li> </ul>  | <ul style="list-style-type: none"> <li>• Continuous accessible route around pool perimeter</li> <li>• Firm, slip-resistant, well-drained surface</li> </ul>                         |
| <b>Pool Ramp (non-submerged)</b>          | <ul style="list-style-type: none"> <li>• 1100 mm wide / 1:12 max slope / 1500 × 1500 mm landing</li> </ul>                         | <ul style="list-style-type: none"> <li>• Dual handrails (865–965 mm high)</li> <li>• Marked water depth; drain at ramp base</li> </ul>  |
| <b>Pool Ramp (submerged)</b>              | <ul style="list-style-type: none"> <li>• Water depth 600–900 mm / adjacent 750 mm walkway</li> </ul>                               | <ul style="list-style-type: none"> <li>• Contrasting finish</li> <li>• Firm, slip-resistant surface</li> </ul>  |
| <b>Pool Steps</b>                         | <ul style="list-style-type: none"> <li>• 50 mm contrasting strip on riser &amp; tread</li> </ul>                                   | <ul style="list-style-type: none"> <li>• Handrails both sides, extending 300 mm beyond edge</li> </ul>  |
| <b>Pool Lift</b>                          | <ul style="list-style-type: none"> <li>• Water <math>\leq 1220</math> mm deep / seat <math>\geq 400</math> mm from edge</li> </ul> | <ul style="list-style-type: none"> <li>• Clear space 915 × 1220 mm</li> <li>• Operable from deck &amp; water</li> <li>• Capacity <math>\geq 135</math> kg (300 lb)</li> </ul>       |
| <b>Therapeutic Pools</b>                  | <ul style="list-style-type: none"> <li>• Temp 33–34 °C / Depth 1050–1200 mm</li> </ul>   | <ul style="list-style-type: none"> <li>• Include submerged benches (Section 2.11) and underwater exercise bars</li> </ul>   |

| Feature / Element        | Minimum / Recommended Dimensions   | Notes / Key Requirements  |
|--------------------------|--|---|
| <b>Public Spas</b>       | <ul style="list-style-type: none"> <li>• Deck 1800 mm (main) / 900 mm (other sides)</li> </ul> | <ul style="list-style-type: none"> <li>• Slip-resistant surfaces; handrails</li> <li>• Max 1:12 slope</li> <li>• Seat depth ≤ 600 mm</li> </ul> |
| <b>Spa Transfer Wall</b> | <ul style="list-style-type: none"> <li>• Height 405–485 mm / Depth 300–400 mm</li> </ul>       | <ul style="list-style-type: none"> <li>• One grab bar 100–150 mm above surface</li> <li>• Adjacent clear space 900 × 2200 mm</li> </ul>         |

## 6.3 Libraries

### Rationale

Libraries should be accessible to all patrons and staff. Both the physical design of the facility and the delivery of services must be considered. Key considerations include:

- Service counters, study carrels, and workstations must allow independent use by wheelchair users, including appropriate knee-space and armrest
- Furnishings should be available at multiple heights to accommodate users standing, seated or children of different ages and sizes. Height-adjustable furniture is recommended
- Workstations with assistive technology such as large displays, screen readers or other accessibility software enhance usability
- Book drop-off slots should be provided at different heights to accommodate standing and seated users

### Application

All libraries must comply with this section including:

- **Fixed Seating and Tables:** at least 10% of fixed seating, tables, or study carrels must be accessible
- **Accessible Routes and Maneuvering Spaces:** provide continuous, level routes connecting all primary library functions, with turning space for mobility devices as per Section 3.3 Interior Accessible Routes
- **Aisles and Circulation:** aisles between shelves, stacks, and catalogues must be level and be wide enough to allow wheelchair users to circulate and make a full turn at the end of aisles
- **Computer Catalogues and Workstations:** provide a range of heights. At least 50% must be accessible
- **Check-Out and Service Counters:** at least one lane must be accessible with clear signage
- **Group Study Rooms:** must be accessible, with adequate passage width, maneuvering space and clear signage
- **Book Security Gates:** must be accessible where provided
- **Shelving:** ensure that stack and shelf areas can be reached by seated users if no staff assistance is available

- **Adjustable Furnishings:** provide options for standing, seated and children

## Requirements

### Interior Accessible Paths of Travel

- Provide interior accessible paths of travel with a clear width of 1200 mm minimum to allow comfortable movement for all users (Figure 100 Aisle Width)
- Ensure paths connect primary activity areas and main circulation routes within the library
- These clear widths apply to general travel routes, entrances and corridors but not specifically to aisles between book stacks
- Accessible seating, tables, and study carrels must be located on an accessible route

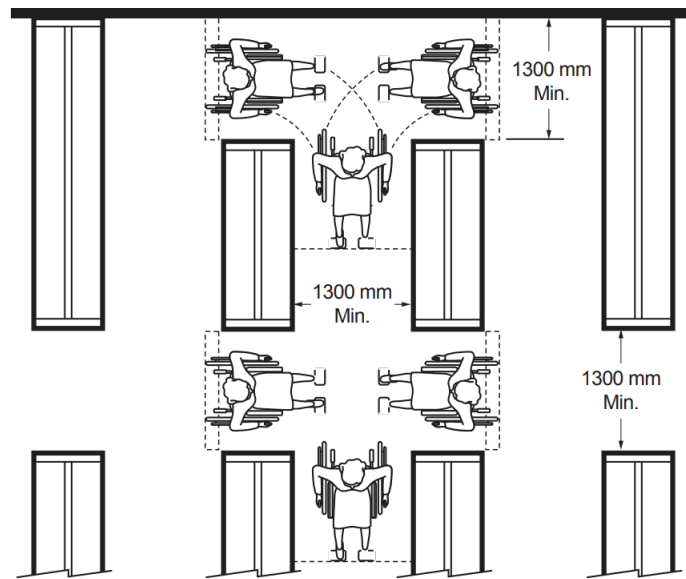

**Figure 159: Aisle Width**

### Seating and Study Areas

- Shelving at seating and study areas must not exceed 1120 mm in height
- Accessible study carrels must provide:
  - Work surfaces with knee and toe space in compliance with Section 2.10 Seating, Tables and Work Surfaces
  - Electrical outlets
  - Minimum 100 lux lighting at the work surface
  - Optional adjustable lighting for users requiring higher illumination

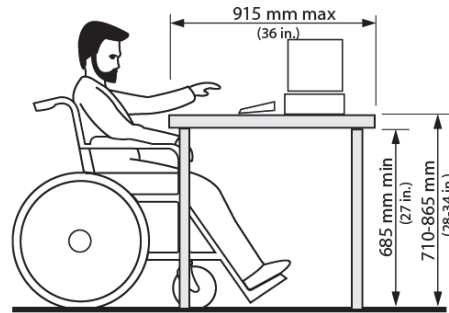

**Figure 160: Work Surfaces**

## Equipment and Workstations

- Card catalogues, computer catalogues and workstations must provide:
  - Maximum work surface height of 860 mm
  - Maximum table depth of 915 mm
  - Knee and toe space for front approach: at least 735 mm high at the front edge, 500 mm deep and 900 mm wide
- Provide at least one movable chair at every information counter, catalogue or workstation

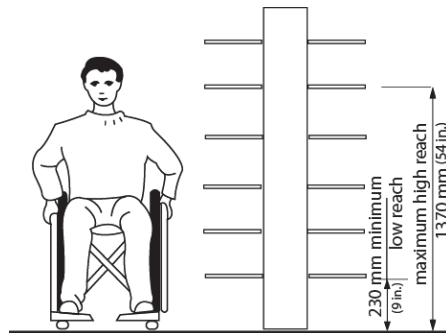

**Figure 161: Reach Heights**

## Book Drop Slots

- Must be on an accessible route
- Must be adjacent to a level clear floor space of 2440 mm by 2440 mm. If not feasible, a minimum of 1525 mm by 1525 mm may be acceptable
- Operable with one hand, with a slot height between 860 mm and 1220 mm
- Provide visual contrast for users with low vision

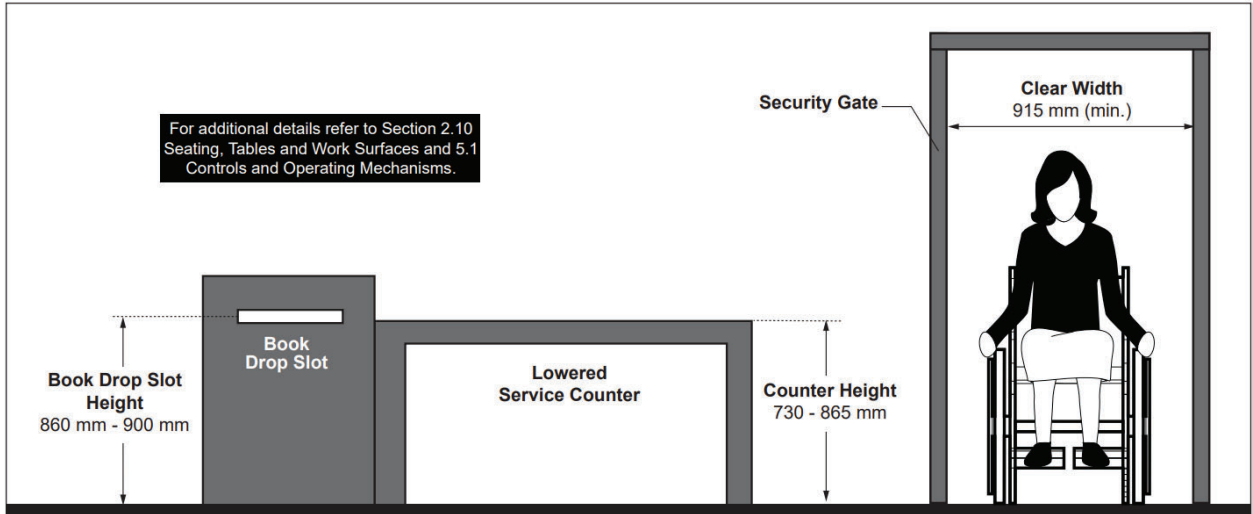

Figure 162: Security Gate, Service Counter and Book Drop - Elevation View

### Book Stacks and Shelving

- Provide aisles between book stacks and shelving with a clear width of 1100 mm minimum, allowing a person using a wheelchair or mobility device to pass and manoeuvre safely
- Ensure there is adequate space at the end of aisles (See Figure 91 for an illustration of the aisle width for book stacks)
- Large print and heavy materials should be on lower shelves for easier access

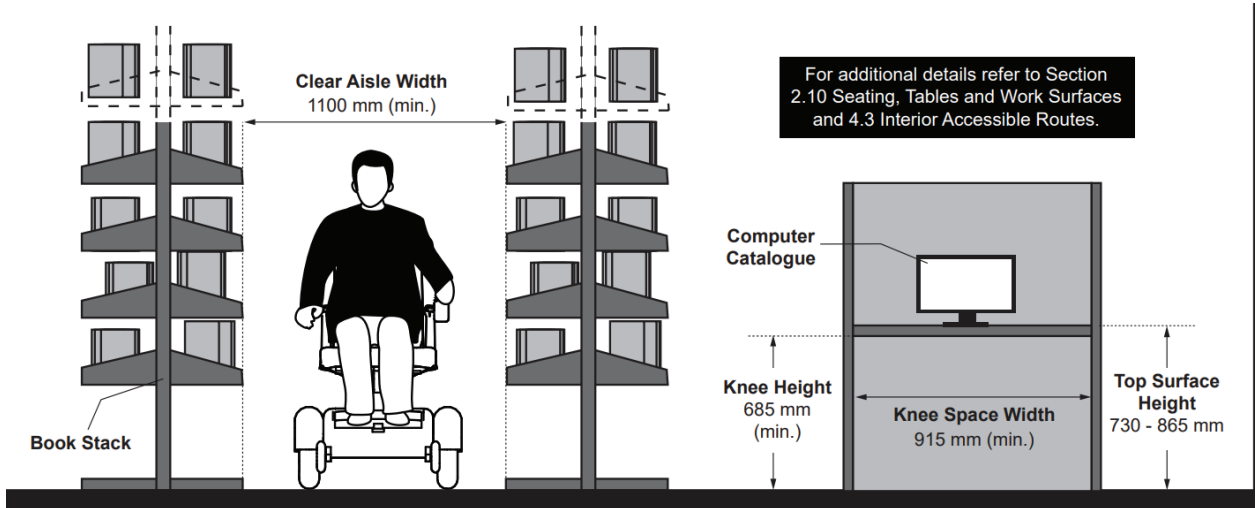
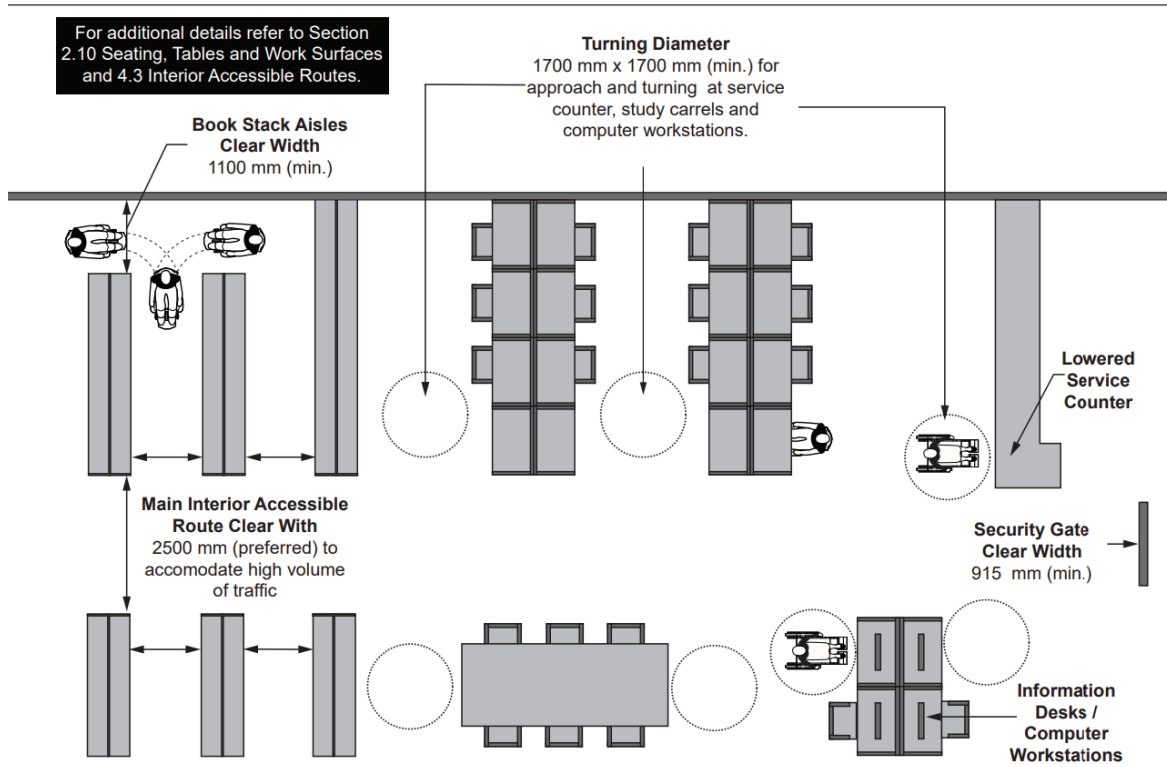

Figure 163: Book Stacks and Accessible Workstation - Elevation View



**Figure 164: Library Design and Layout - Plan View**

## Reading Lounges and Study Areas

- Provide a variety of flexible seating options
- Ensure furniture contrasts with surroundings for visibility
- At least 10% of study tables and carrels must be accessible
- Provide suitable knee and toe clearance at all study surfaces
- Incorporate electrical outlets

## Assistive Technology

- Provide accessible touch screens within reach
- Include adaptive controls, scrolling features, and on-screen keyboards
- Provide specialized equipment for users with vision loss, such as screen reading software, scanners, and CCTV magnifiers
- Where feasible, provide headphones or standard audio jacks within reach
- Include voice recognition software and accessible Wi-Fi/download centres

## Lighting

- Book stack lighting should provide a minimum of 200 lux at a nominal working height of 920 mm

- Adjustable task lighting should be available at study and reading tables
- Lighting must comply with Section 5.6 Lighting

**Table 92: Library Accessibility at a Glance**

| <b>Element</b>                                | <b>Key Requirement</b>  | <b>Minimum Dimensions / Notes</b>   |
|---|---|---|
| <b>Interior accessible paths of travel</b>    | <ul style="list-style-type: none"> <li>• Clear, unobstructed paths connecting main circulation areas</li> </ul>               | <ul style="list-style-type: none"> <li>• 1300 mm minimum width</li> </ul>   |
| <b>Aisles between book stacks / shelving</b>  | <ul style="list-style-type: none"> <li>• Clear floor space allowing passage and manoeuvre</li> </ul>                          | <ul style="list-style-type: none"> <li>• 1100 mm minimum width</li> <li>• Turning space at aisle ends</li> </ul>  |
| <b>Fixed seating, tables, study carrels</b>   | <ul style="list-style-type: none"> <li>• Accessible, properly signposted</li> </ul>   | <ul style="list-style-type: none"> <li>• At least 10% or minimum of one</li> <li>• Knee and toe space as per 2.10</li> </ul>  |
| <b>Workstations &amp; computer catalogues</b> | <ul style="list-style-type: none"> <li>• Range of heights</li> <li>• Adjustable preferred</li> </ul>                          | <ul style="list-style-type: none"> <li>• 860 mm maximum work surface height</li> <li>• Table depth 915 mm</li> <li>• Knee/toe space front approach: <ul style="list-style-type: none"> <li>○ 735 mm high</li> <li>○ 500 mm deep</li> <li>○ 900 mm wide</li> </ul> </li> </ul> |
| <b>Book drop slots</b>                        | <ul style="list-style-type: none"> <li>• Accessible location and height</li> </ul>  | <ul style="list-style-type: none"> <li>• Operable one-hand</li> <li>• 860–1220 mm above floor</li> <li>• Adjacent level clear floor space 2440 × 2440 mm (retrofit min 1525 × 1525 mm)</li> </ul>   |
| <b>Book stacks / carousels</b>                | <ul style="list-style-type: none"> <li>• Reachable by seated users</li> <li>• Policy for assistance</li> </ul>                | <ul style="list-style-type: none"> <li>• Side reach depth 500 mm</li> <li>• Large print / heavier materials on lower shelves</li> </ul>   |
| <b>Reading lounges &amp; study areas</b>      | <ul style="list-style-type: none"> <li>• Flexible seating</li> <li>• Colour contrast</li> <li>• Electrical outlets</li> </ul> | <ul style="list-style-type: none"> <li>• Clear floor space, knee/toe space</li> <li>• Adjustable lighting where needed</li> </ul>   |
| <b>Assistive technology</b>                   | <ul style="list-style-type: none"> <li>• Accessible for varying disabilities</li> </ul>                                       | <ul style="list-style-type: none"> <li>• Screen readers, adaptive mouse/keyboard, CCTV magnifiers, audio jacks, voice recognition, Wi-Fi download centres</li> </ul>  |
| <b>Lighting</b>                               | <ul style="list-style-type: none"> <li>• Appropriate for stacks, reading, and study</li> </ul>                                | <ul style="list-style-type: none"> <li>• Over aisles: minimum 200 lux at 920 mm</li> <li>• Adjustable lighting at study tables</li> </ul>   |

| <b>Element</b>                                | <b>Key Requirement</b>   | <b>Minimum Dimensions / Notes</b>  |
|---|--|--|
| <b>Circulation &amp; information counters</b> | <ul style="list-style-type: none"> <li>• Accessible for seated and standing users</li> </ul> | <ul style="list-style-type: none"> <li>• Knee/toe space</li> <li>• Height-adjustable counter surfaces</li> <li>• Minimum of one movable chair per workstation</li> </ul> |
| <b>Security gates</b>                         | <ul style="list-style-type: none"> <li>• Accessible operation</li> </ul>                     | <ul style="list-style-type: none"> <li>• Clear width, maneuverable for wheelchair users</li> </ul>   |

## 6.4 Cafeteria and Dining Facilities

### Rationale

Cafeteria serving areas and dining spaces must provide equitable, independent, and dignified access for all patrons, including those using mobility aids, persons with vision loss, and persons with limited reach or dexterity.

Accessible design features ensure that:

- Patrons can approach, select, and carry food items independently
- Seating is inclusive, comfortable, and distributed throughout the space
- Wayfinding and menu information are clear and perceivable

### Application

This section applies to all new and renovated cafeteria and dining facilities, including:

- Self-service counters and tray lines
- Cashier and queuing areas
- Fixed seating and tables
- Outdoor dining areas
- Banquet halls, head tables, and lecterns
- Vending and dispensing equipment

### General Principles

- Provide a minimum clear aisle width of 1100 mm at serving and tray lines
- Tray slides: 730-865 mm above finished floor (A.F.F.)
- Install at least 50% of shelving and displays between 400 mm and 1370 mm for side reach
- Limit maximum shelf depth to 500 mm
- Provide accessible floor space (minimum 1800 x 1800 mm) adjacent to service counters
- At least 20% of fixed tables shall be accessible, with knee and toe clearance per Section 2.10 Seating Tables and Work Surfaces, and distributed throughout the dining area
- At least one accessible cashier aisle shall be provided at 1100 mm wide; more are preferred

- Self-service devices (dishware, condiments, beverages, vending machines) shall comply with reach range requirements in Section 2.1 Space and Reach Requirements
- Provide power-assisted doors at main cafeteria entrances where feasible
- Menus shall be provided in high-contrast large print, with tactile or digital options available on request
- Platforms for head tables or lecterns shall be accessible via ramps or lifts, per Section 3.5 Elevating Devices
- Lighting, signage and acoustic conditions must comply with Sections 5.6 Lighting and 5.7 Signage and Wayfinding where applicable

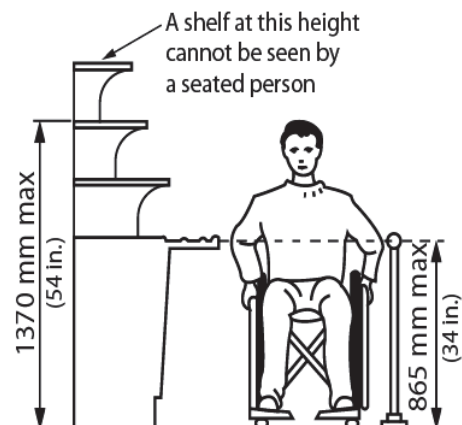

Figure 165: Self Serve Counter

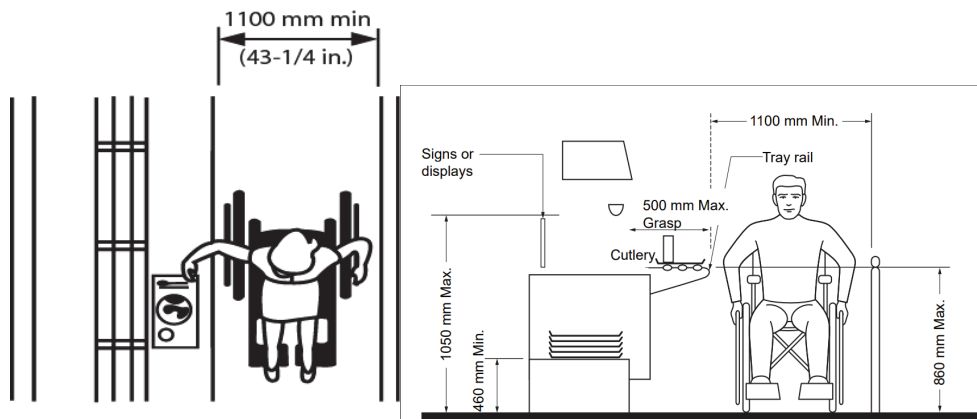

Figure 166: Aisle Width

**Table 93: Cafeterias and Dining Facilities at a Glance**

| Feature                                | Minimum / Recommended Dimensions   | Notes / Key Requirements   |
|--|--|--|
| <b>Aisle Width (Serving Line)</b>      | <ul style="list-style-type: none"> <li>• <math>\geq 1100</math> mm</li> </ul>                                | <ul style="list-style-type: none"> <li>• Clear width between tray slide and separating rail</li> </ul>               |
| <b>Tray Slide Height</b>               | <ul style="list-style-type: none"> <li>• 730–865 mm AFF</li> </ul>   | <ul style="list-style-type: none"> <li>• Smooth sliding surface</li> <li>• Minimal force required</li> </ul>         |
| <b>Shelving / Displays</b>             | <ul style="list-style-type: none"> <li>• 400–1370 mm AFF (<math>\geq 50\%</math> of shelves)</li> </ul>      | <ul style="list-style-type: none"> <li>• Side approach</li> <li>• Unobstructed access</li> </ul>                     |
| <b>Shelf Depth</b>                     | <ul style="list-style-type: none"> <li>• <math>\leq 500</math> mm</li> </ul>                                 | <ul style="list-style-type: none"> <li>• Ensures accessible reach</li> </ul>   |
| <b>Accessible Tables</b>               | <ul style="list-style-type: none"> <li>• <math>\geq 20\%</math> of tables</li> </ul>                         | <ul style="list-style-type: none"> <li>• Comply with Section 2.10</li> <li>• Distributed throughout space</li> </ul> |
| <b>Cashier Aisles</b>                  | <ul style="list-style-type: none"> <li>• <math>\geq 1100</math> mm (<math>\geq 1</math> required)</li> </ul> | <ul style="list-style-type: none"> <li>• Preferable all aisles accessible</li> </ul>                                 |
| <b>Outdoor Dining</b>                  | <ul style="list-style-type: none"> <li>• N/A</li> </ul>  | <ul style="list-style-type: none"> <li>• Must comply with Section 2.10</li> </ul>                                    |
| <b>Self-Service Devices</b>            | <ul style="list-style-type: none"> <li>• 400–1200 mm AFF</li> </ul>  | <ul style="list-style-type: none"> <li>• Tableware, condiments, beverages per Section 2.1</li> </ul>                 |
| <b>Banquet Platforms / head tables</b> | <ul style="list-style-type: none"> <li>• N/A</li> </ul>  | <ul style="list-style-type: none"> <li>• Accessible via ramps or lifts per Section 3.5</li> </ul>                    |
| <b>Vending / Beverage Equipment</b>    | <ul style="list-style-type: none"> <li>• N/A</li> </ul>  | <ul style="list-style-type: none"> <li>• On accessible route per Section 3.3</li> </ul>                              |
| <b>Queuing Areas</b>                   | <ul style="list-style-type: none"> <li>• N/A</li> </ul>  | <ul style="list-style-type: none"> <li>• Must comply with Section 6.9</li> </ul>                                     |

## 6.5 Kitchens and Kitchenettes

### Rationale

Kitchens and kitchenettes must be designed to allow independent and safe use by all persons, including those with mobility devices, vision loss, or limited dexterity. Adequate space, accessible storage, and intuitive appliances ensure equitable access.

### Application

This section applies to all staff and public kitchens, kitchenettes, and coffee stations in municipal facilities.

Commercial kitchens are excluded.

At least 50% of shelving, counters, and storage shall be accessible.

### Design Requirements

#### General Layout

- Pass-through kitchens must have two entry points and a minimum clearance of 1500 mm (1100 mm allowed in retrofit if technically infeasible)
- U-shaped kitchens must have a minimum clearance of 2500 mm (2130 mm in retrofit)
- L-shaped kitchens must have a minimum clearance of 2500 mm (1500 mm in retrofit)
- Provide high contrast finishes between:
  - Cabinets and appliances from adjacent walls and floors
  - Countertops from cabinets and walls
  - Operable hardware from cabinet surfaces

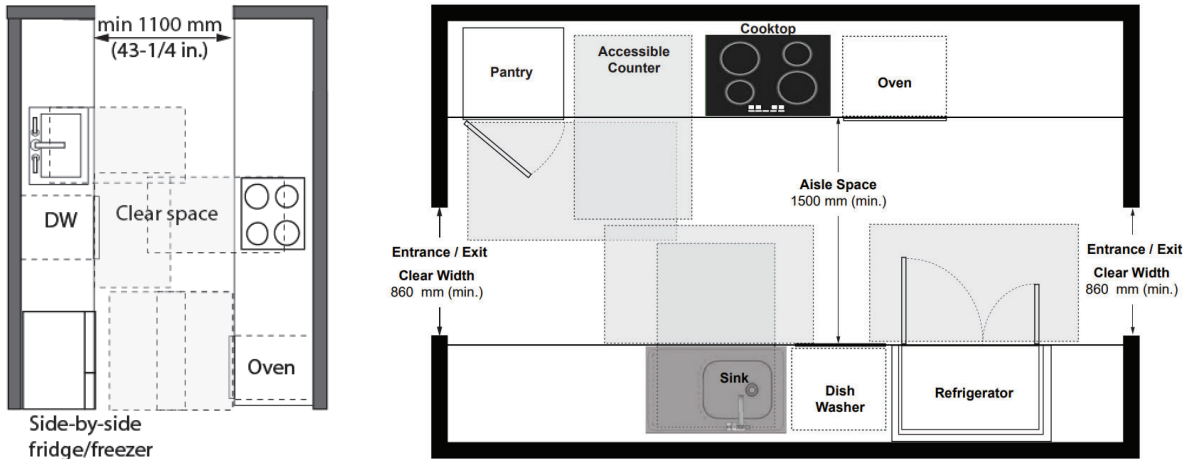

Figure 167: Pass-Through Kitchen

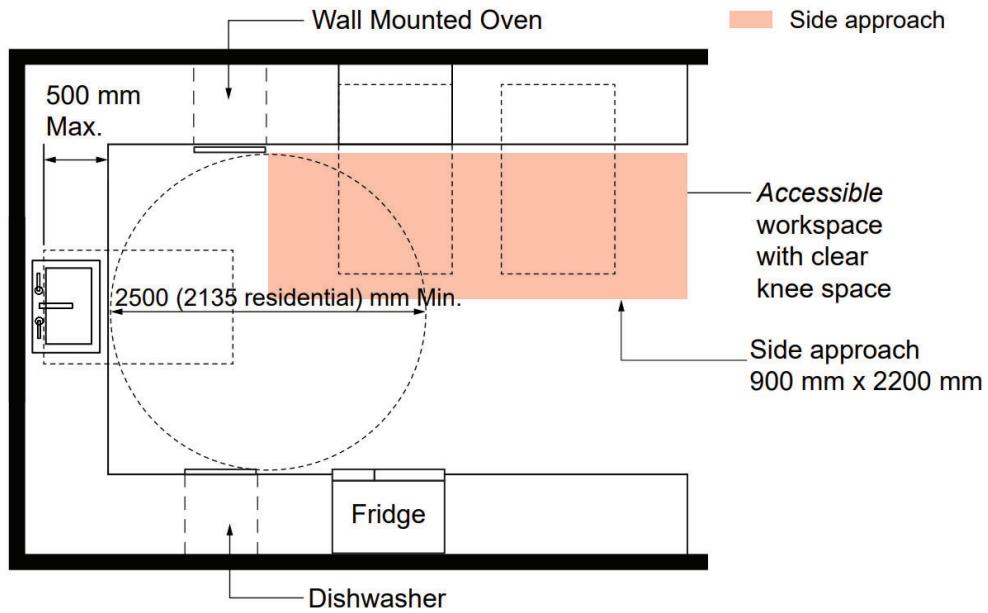

Figure 168: U-Shaped Kitchen

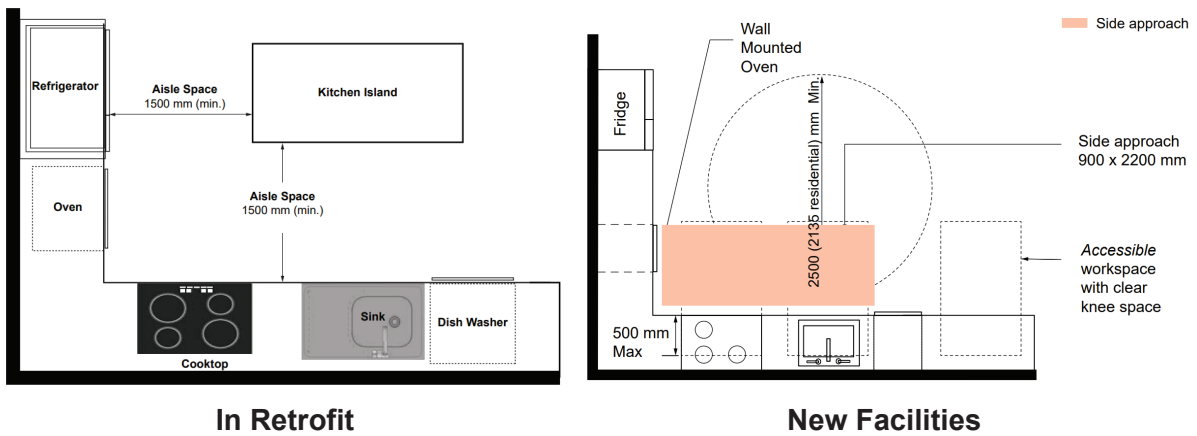
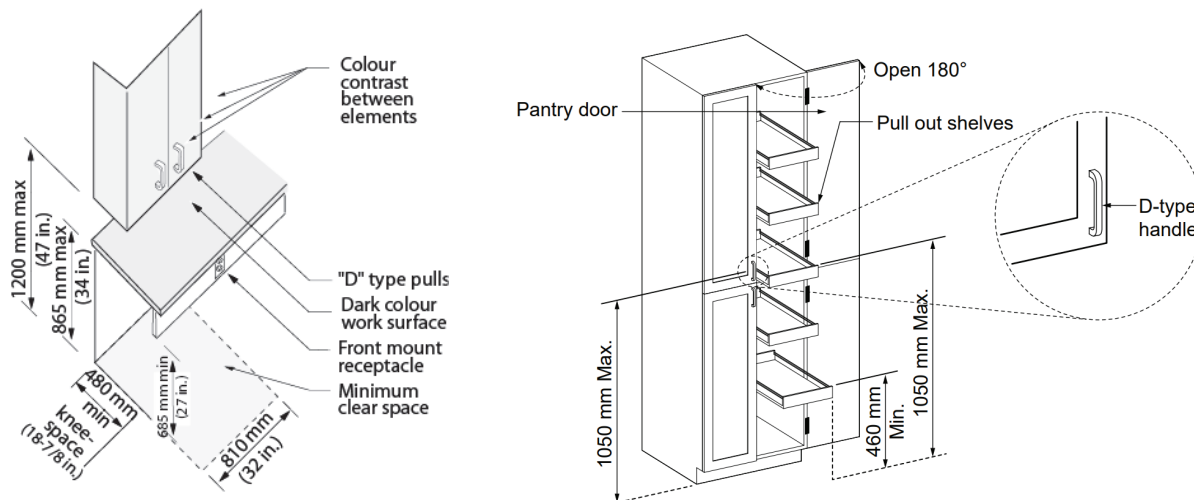

Figure 169: L-Shaped Kitchen with Island

## Storage

Storage elements must:

- Be located on an accessible route with clear floor space per Section 2.1 Space and Reach Requirements
- Comply with at least one of the reach ranges in Section 2.1 Space and Reach Requirements
- Operable with one hand without tight grasping, pinching or twisting
- Where possible, have pull-out shelving or drawers (recommended)



**Figure 170: Storage Elements**

## Kitchen Sinks

- Forward approach preferred with knee space 810 mm wide, 480 mm deep and 685 mm high
  - Exception: Parallel approach permitted where a cooktop or range is not provided, or for wet bars
- Counter or sink rim height must be 710–865 mm
- Faucets and controls must have lever handles and tactile marking and comply with Section 5.1 Controls and Operating Mechanisms
- Pipes must be insulated or otherwise configured to prevent contact

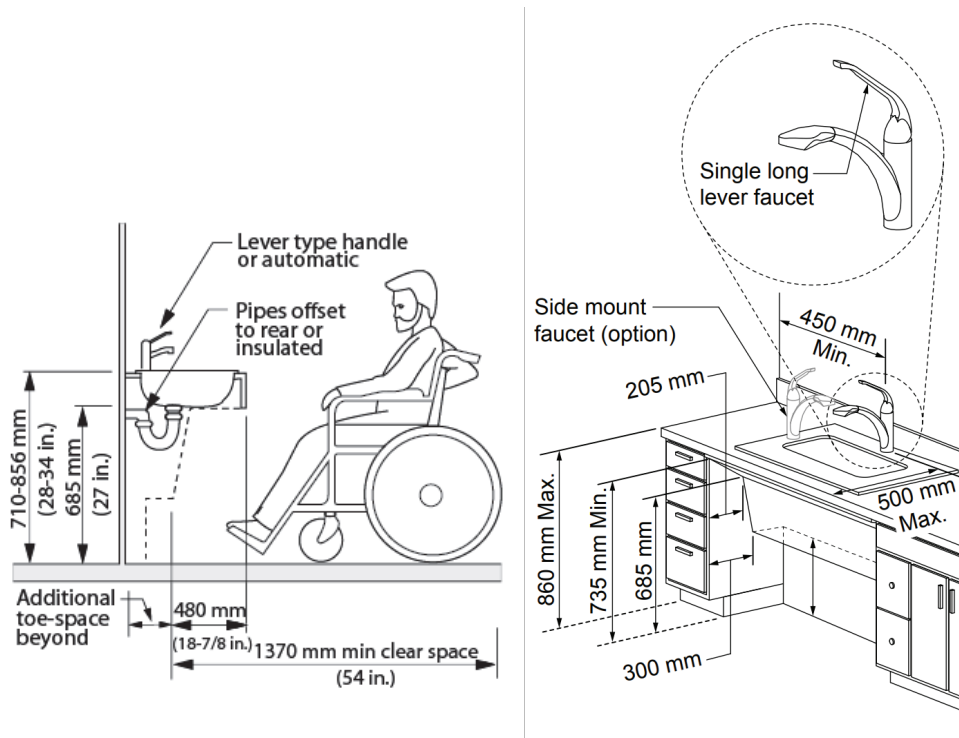

**Figure 171: Kitchen Sink**

## Appliances

- Microwaves and ovens must be mounted with controls no more than 1100 mm above the floor
- Dishwashers must have clear space beside them and not block adjacent access routes when open
- Controls and operable parts shall comply with Section 5.1 Controls and Operating Mechanisms
  - Exception: Appliance doors and latching devices

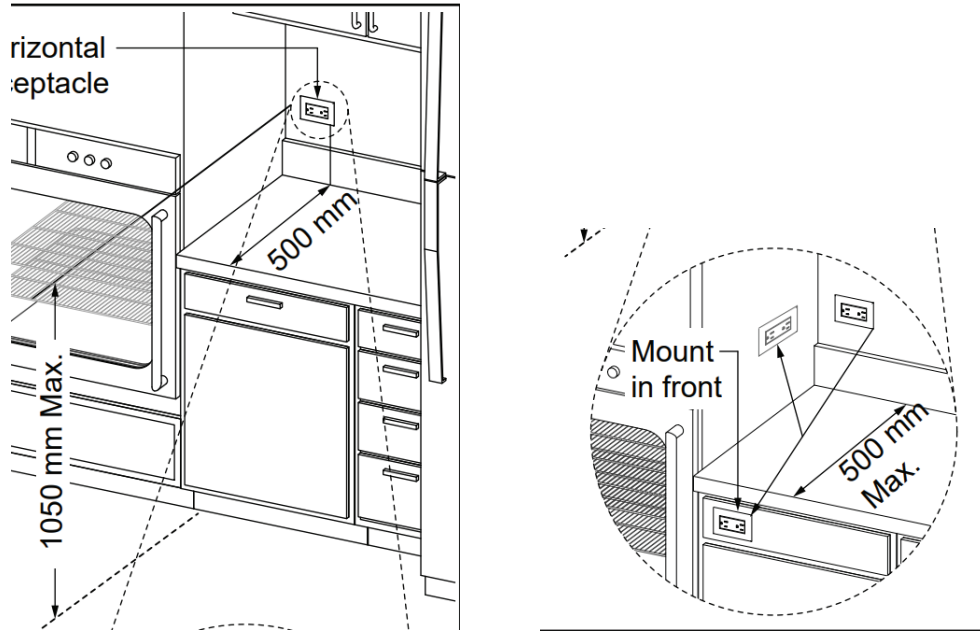

**Figure 172: Duplex Receptacle Mounting**

## Ranges and Cooktops

- Controls must be positioned at the front or side, not across burners
- For forward approach, provide knee space of 810 mm wide, 480 mm deep, 685 mm high
- Surfaces shall be insulated or configured to prevent burns or shocks

### Recommendations:

- Electric cooktops should indicate when burners remain hot after use
- Gas burners should be self-igniting and operable with one hand
- Ceramic hobs are preferable to allow sliding pans instead of lifting

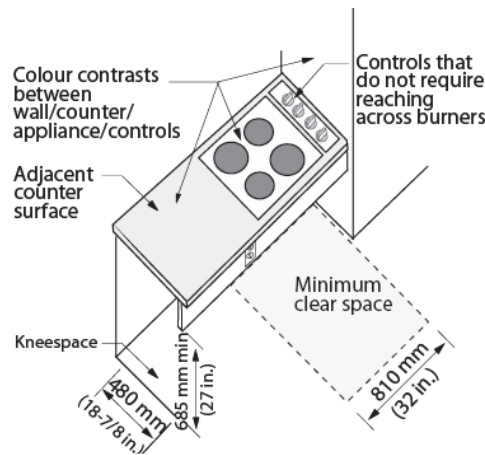

**Figure 173: Cook Top**

## Ovens

- Controls shall be located on the front and no higher than 1400 mm
- Side-hinged ovens shall have an adjacent work surface at the latch side and a pull-out shelf below
- Bottom-hinged ovens shall have a work surface beside the door
- In facilities with children's programs, ranges and ovens shall have a safety switch to deactivate controls

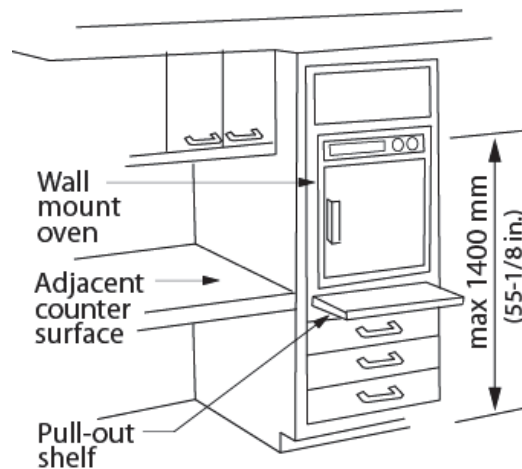

**Figure 174: Wall-Mounted Oven**

## Refrigerators and Freezers

- At least 50% of freezer storage shall be no more than 1370 mm above the floor
  - A parallel approach shall be provided, with clear floor space immediately adjacent, offset no more than 610 mm from the front face

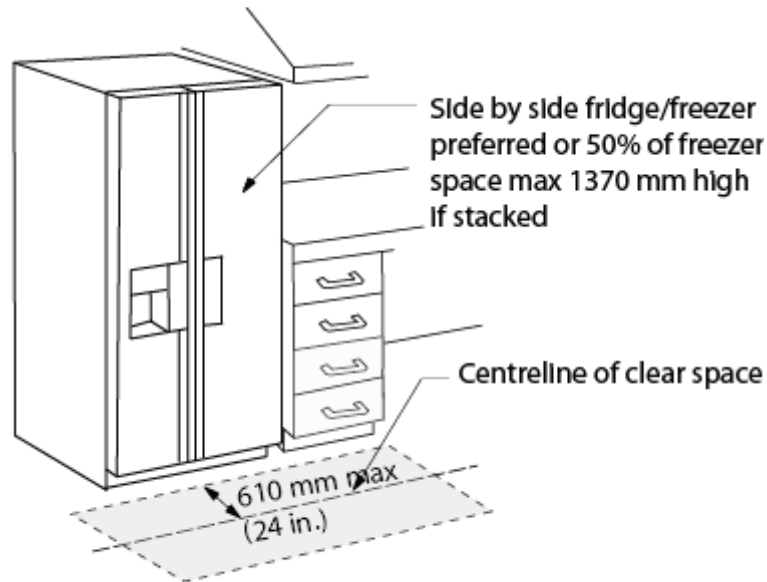

**Figure 175: Fridge/Freezer**

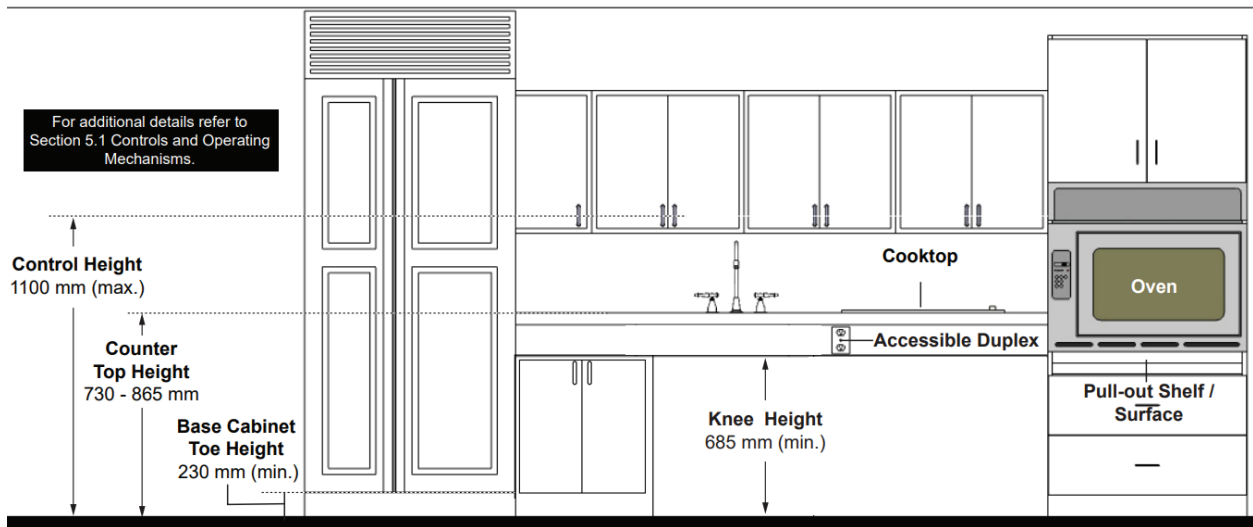

**Figure 176: Kitchen Amenities**

## Electrical

- Receptacles and switches positioned 400–1200 mm AFF
- Provide at least one accessible outlet above counter height

**Table 94: Kitchens and Kitchenettes at a Glance**

| Feature                      | Minimum / Recommended Dimensions  | Notes / Key Requirements   |
|------------------------------|---|--|
| <b>Pass-Through Kitchens</b> | <ul style="list-style-type: none"> <li>• ≥1500 mm between opposing elements (1100 mm retrofit)</li> </ul> | <ul style="list-style-type: none"> <li>• Two entries required</li> </ul>   |
| <b>U-Shaped Kitchens</b>     | <ul style="list-style-type: none"> <li>• ≥2500 mm (2130 mm retrofit)</li> </ul>                           | <ul style="list-style-type: none"> <li>• Continuous three-sided layout</li> </ul>                                |
| <b>L-Shaped Kitchens</b>     | <ul style="list-style-type: none"> <li>• ≥2500 mm (1500 mm retrofit)</li> </ul>                           | <ul style="list-style-type: none"> <li>• With island or adjacent walls</li> </ul>                                |
| <b>Colour Contrast</b>       | <ul style="list-style-type: none"> <li>• N/A</li> </ul>   | <ul style="list-style-type: none"> <li>• Differentiate counters, cabinets, appliances, and hardware</li> </ul>   |
| <b>Storage Reach Range</b>   | <ul style="list-style-type: none"> <li>• 400–1370 mm AFF (≥50% shelves)</li> </ul>                        | <ul style="list-style-type: none"> <li>• On accessible route</li> <li>• Operable parts per 5.1</li> </ul>        |
| <b>Sink – Knee Space</b>     | <ul style="list-style-type: none"> <li>• ≥810 mm wide × 480 mm deep × 685 mm high</li> </ul>              | <ul style="list-style-type: none"> <li>• Required for forward approach</li> </ul>                                |
| <b>Sink – Counter Height</b> | <ul style="list-style-type: none"> <li>• 710–865 mm AFF</li> </ul>  | <ul style="list-style-type: none"> <li>• Rim or countertop height</li> </ul>                                     |
| <b>Sink – Protection</b>     | <ul style="list-style-type: none"> <li>• N/A</li> </ul>   | <ul style="list-style-type: none"> <li>• Insulate pipes</li> <li>• No sharp surfaces</li> </ul>                  |
| <b>Faucets</b>               | <ul style="list-style-type: none"> <li>• N/A</li> </ul>   | <ul style="list-style-type: none"> <li>• Lever/tactile markings</li> <li>• Intuitive operation</li> </ul>        |
| <b>Appliances</b>            | <ul style="list-style-type: none"> <li>• 400–1200 mm AFF (controls)</li> </ul>                            | <ul style="list-style-type: none"> <li>• Clear floor space at appliances</li> <li>• Accessible routes</li> </ul> |
| <b>Microwave Controls</b>    | <ul style="list-style-type: none"> <li>• ≤1100 mm AFF</li> </ul>  | <ul style="list-style-type: none"> <li>• Within seated reach</li> </ul>  |
| <b>Cooktop – Knee Space</b>  | <ul style="list-style-type: none"> <li>• ≥810 mm wide × 480 mm deep × 685 mm high</li> </ul>              | <ul style="list-style-type: none"> <li>• Prevent burns/shock</li> <li>• No reaching across burners</li> </ul>    |

| Feature                         | Minimum / Recommended Dimensions  | Notes / Key Requirements  |
|---------------------------------|---|---|
| <b>Ovens</b>                    | <ul style="list-style-type: none"> <li>• Controls ≤1400 mm AFF</li> </ul>     | <ul style="list-style-type: none"> <li>• Work surface adjacent</li> <li>• Pull-out shelf where side-hinged</li> </ul> |
| <b>Refrigerators / Freezers</b> | <ul style="list-style-type: none"> <li>• ≥50% freezer ≤1370 mm AFF</li> </ul> | <ul style="list-style-type: none"> <li>• Parallel approach with offset ≤610 mm</li> </ul>                             |

### Cross-Reference

See also **Section 2.10 Seating, Tables and Work Surfaces** and **Section 5.1 Controls and Operating Mechanisms** for related reach range and operability requirements.

### Technical Note – Accessible Kitchen Design Standards

While this section outlines key accessibility requirements, detailed appliance specifications, ergonomic clearances, and safety provisions should be developed by qualified designers in accordance with recognized standards such as:

- CSA B651 (Accessible Design for the Built Environment)
- ISO 21542 (Building Construction – Accessibility and Usability of the Built Environment)
- ANSI A117.1 (Accessible and Usable Buildings and Facilities)

Designers should ensure kitchens and kitchenettes support independent, safe, and comfortable use by all occupants through compliant layouts, appliance selection, and control placement.

## 6.6 Waiting and Queuing Areas

### Rationale

Waiting and queuing areas must be designed to provide safe, dignified, and independent access for all persons, including those using mobility devices, service animals, or with vision loss. Providing adequate manoeuvring space, cane-detectable barriers, accessible seating, and weather protection ensures inclusive use.

### Application

This section applies to all permanent and temporary waiting and queuing areas, both indoors and outdoors.

### Design Requirements

#### Seating

- At least 3% of seating, and no fewer than two seats, shall be accessible
- Accessible seating spaces must be at least 900 mm wide by 1500 mm deep for front approach, adjacent to fixed seating to allow space for mobility devices, equipment or service animals
- Seating areas must be visible from entry, positioned along accessible routes and recessed where possible to avoid circulation conflicts
- Seating shall be on the same level as accessible routes with no steps or curbs
- Accessible paths through seating rows must be at least 1500 mm wide
- Provide a mix of fixed and movable seating to allow flexibility
- At least some seating must include armrests for transfer support
- Outdoor waiting areas should be sheltered or under cover where feasible

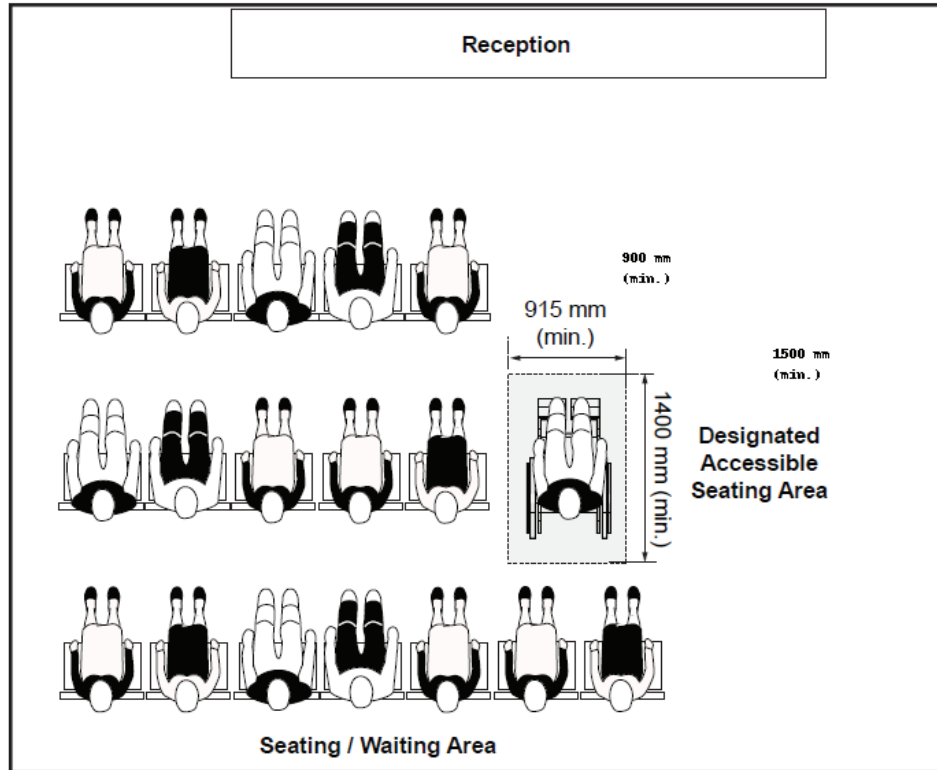

Figure 177: Waiting Area

## Queuing Areas

- Queuing areas must be located on an accessible routes per Section 3.3 Interior Accessible Routes
- Provide directional and entry signage in accordance with Section 5.7 Signage and Wayfinding
- Where provided, ticketing dispensers must comply with Section 5.8 Self-service Kiosks

## Queuing Guides

- Provide a clear width of at least 1100 mm between ropes, bars or solid barriers
- Provide clear floor space at points where guides begin, end or change direction, in compliance with Section 3.3 Interior Accessible Routes (see Figures 118 and 119)
- Guides arranged in parallel lines with consistent spacing
- Provide at least 70% contrast with surroundings
- Cane-detectable barriers at or below 680 mm maximum A.F.F.

**Note:** Retractable-belt stanchions should be used sparingly, as they can create tripping hazards when not in place or are retracted across main accessible routes.

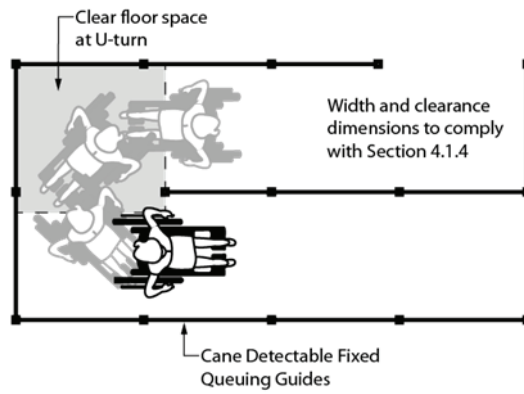

Figure 178: Queuing Guides and Waiting Areas

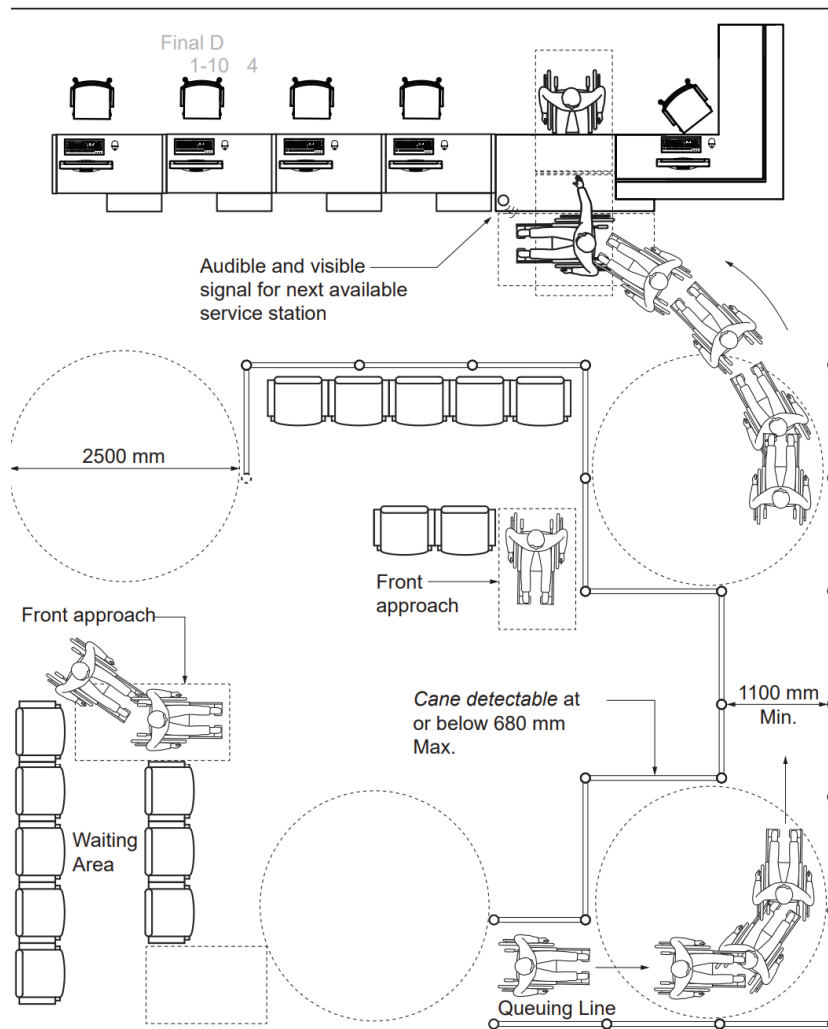

Figure 179: Queuing Guides and Waiting Areas

## Cross-Reference

See also Section 2.10 Seating, Tables and Work Surfaces, Section 3.3 Interior Accessible Routes, and Section 5.7 Signage and Wayfinding for related requirements on maneuvering space, circulation, and information clarity.

## Technical Note – Accessible Waiting and Queuing Standards

Detailed performance criteria for circulation, reach ranges, and barrier detection should follow recognized standards such as:

- CSA B651 (Accessible Design for the Built Environment)
- ISO 21542 (Building Construction – Accessibility and Usability of the Built Environment)
- OBC Section 3.8 (Barrier-Free Design)

Designers should ensure waiting and queuing environments provide equitable access, visibility, and comfort for all users through consistent widths, tactile guidance, and safe queuing management.

**Table 95: Waiting and Queuing Areas at a Glance**

| Feature                         | Minimum / Recommended Dimensions   | Notes / Key Requirements   |
|---------------------------------|--|--|
| <b>Accessible Seating</b>       | <ul style="list-style-type: none"> <li>• <math>\geq 3\%</math> (minimum 2 spaces)</li> </ul>     | <ul style="list-style-type: none"> <li>• Clearly visible</li> <li>• Adjacent to accessible routes</li> </ul> |
| <b>Accessible Seating Space</b> | <ul style="list-style-type: none"> <li>• 900 mm wide <math>\times</math> 1500 mm long</li> </ul> | <ul style="list-style-type: none"> <li>• Adjacent to fixed seating for front approach</li> </ul>             |
| <b>Path Between Rows</b>        | <ul style="list-style-type: none"> <li>• <math>\geq 1500</math> mm</li> </ul>                    | <ul style="list-style-type: none"> <li>• Clear circulation</li> </ul>  |
| <b>Outdoor Waiting Areas</b>    | <ul style="list-style-type: none"> <li>• N/A</li> </ul>  | <ul style="list-style-type: none"> <li>• Should be sheltered/covered</li> </ul>                              |
| <b>Queuing Aisle Width</b>      | <ul style="list-style-type: none"> <li>• <math>\geq 1100</math> mm</li> </ul>                    | <ul style="list-style-type: none"> <li>• Between ropes, bars, or barriers</li> </ul>                         |
| <b>Queuing Turning Space</b>    | <ul style="list-style-type: none"> <li>• <math>\geq 1500 \times 1500</math> mm</li> </ul>        | <ul style="list-style-type: none"> <li>• At changes in direction, beginning, and end</li> </ul>              |
| <b>Queuing Guide Contrast</b>   | <ul style="list-style-type: none"> <li>• <math>\geq 70\%</math></li> </ul>                       | <ul style="list-style-type: none"> <li>• Tonal/colour contrast with surroundings</li> </ul>                  |
| <b>Cane Detectable</b>          | <ul style="list-style-type: none"> <li>• <math>\leq 680</math> mm AFF</li> </ul>                 | <ul style="list-style-type: none"> <li>• Ropes, bars, or barriers detectable by cane</li> </ul>              |
| <b>Signage</b>                  | <ul style="list-style-type: none"> <li>• N/A</li> </ul>  | <ul style="list-style-type: none"> <li>• Directional/informational per</li> </ul>                            |

| <b>Feature</b>              | <b>Minimum / Recommended Dimensions</b>               | <b>Notes / Key Requirements</b>  |
|-----------------------------|---|--|
|                             |   | Section 5.7  |
| <b>Ticketing Dispensers</b> | <ul style="list-style-type: none"><li>• N/A</li></ul> | <ul style="list-style-type: none"><li>• On accessible route</li><li>• Comply with kiosks section</li></ul> |

## 6.7 Balconies, Porches, Terraces and Patios

### Rationale

Balconies, porches, terraces and patios provide important outdoor spaces for recreation, relaxation, and socialization. Accessibility in these areas ensures that persons with mobility impairments and other diverse needs can use them independently and safely. Design must focus on safety, ease of access, clear visibility and comfort, including protection from sun, wind and precipitation.

### Application

This section applies to balconies, porches, terraces and patios provided for public, client, customer or employee use.

### Design Requirements

#### Location and Access

- Must be located on an accessible route
- The minimum depth must be 2440 mm
- In retrofit situations, the minimum depth may be reduced to 1525 mm if 2440 mm is technically infeasible
- Where outswing doors are used, a minimum depth of 1100 mm must be provided between the door and any adjacent guard or railing
- Thresholds at balcony doors should be flush where possible; if necessary, they must comply with Section 1.2 Ground and Floor Surfaces

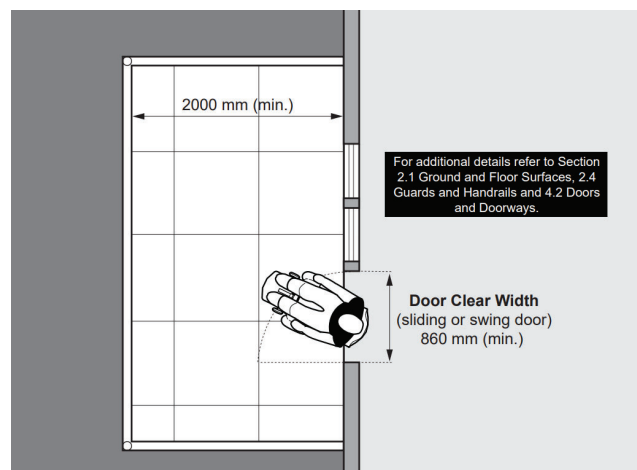

Figure 180: Balcony / Terrace - Plan View

## Surface and Drainage

- Surfaces must comply with the requirements of Section 1.2 Ground and Floor Surfaces
- Surfaces must slope to remove water, with a maximum slope of 2%
- Use firm, stable and slip-resistant materials

## Railings and Guards

- Railings and guards must comply with the Ontario Building Code (OBC)
- Provide clear vision below top rail for seated users (wheelchairs or scooters) to maintain views of the surrounding environment
- Use high contrast finishes for visibility and a minimum 70% transparency where possible

## Door Design

- Locate doors so they open against a side wall or railing to avoid obstruction
- Glazing in doors must comply with Section 3.2 Doors and Doorways

## Cross-Reference

See also **Section 1.2 Ground and Floor Surfaces** and **Section 3.2 Doors and Doorways** for detailed surface and door-threshold requirements related to outdoor spaces.

## Technical Note – Accessible Outdoor Spaces and Guards

Design specifications for balcony and terrace safety, including guard height, load capacity, and glazing, must follow the Ontario Building Code (OBC) and CSA B651 (Accessible Design for the Built Environment).

Designers should ensure outdoor spaces are usable by all individuals through level transitions, proper drainage, safe railing design, and consistent color and tonal contrast for visibility and comfort.

**Table 96: Balconies, Porches, Terraces and Patios at a Glance**

| Feature                 | Minimum / Recommended Dimensions   | Notes / Key Requirements   |
|-------------------------|--|--|
| Minimum Depth           | <ul style="list-style-type: none"> <li>• <math>\geq 2440</math> mm (1525 mm retrofit)</li> </ul> | <ul style="list-style-type: none"> <li>• Clear usable outdoor space</li> </ul>     |
| Outswing Door Clearance | <ul style="list-style-type: none"> <li>• <math>\geq 1100</math> mm</li> </ul>                    | <ul style="list-style-type: none"> <li>• Between door and guard/railing</li> </ul> |

| Feature                  | Minimum / Recommended Dimensions  | Notes / Key Requirements  |
|--------------------------|---|---|
| <b>Thresholds</b>        | <ul style="list-style-type: none"> <li>• Flush preferred</li> <li>• ≤13 mm bevel</li> </ul> | <ul style="list-style-type: none"> <li>• Avoid barriers at entrances</li> </ul>   |
| <b>Surface Slope</b>     | <ul style="list-style-type: none"> <li>• ≤2%</li> </ul>                                     | <ul style="list-style-type: none"> <li>• Firm, stable, slip-resistant</li> <li>• Drainage provided</li> </ul>                             |
| <b>Railings / Guards</b> | <ul style="list-style-type: none"> <li>• As per OBC</li> </ul>                              | <ul style="list-style-type: none"> <li>• Provide clear seated sightlines</li> <li>• ≥70% transparency</li> <li>• High contrast</li> </ul> |
| <b>Edge Markings</b>     | <ul style="list-style-type: none"> <li>• N/A</li> </ul>                                     | <ul style="list-style-type: none"> <li>• Contrasting strip at perimeter edges</li> </ul>  |
| <b>Door Swing</b>        | <ul style="list-style-type: none"> <li>• N/A</li> </ul>                                     | <ul style="list-style-type: none"> <li>• Open against wall or guard to avoid obstruction</li> </ul>                                       |
| <b>Glazing in Doors</b>  | <ul style="list-style-type: none"> <li>• N/A</li> </ul>                                     | <ul style="list-style-type: none"> <li>• Must comply with Section 3.2</li> </ul>  |
| <b>Shelter / Shade</b>   | <ul style="list-style-type: none"> <li>• N/A</li> </ul>                                     | <ul style="list-style-type: none"> <li>• Provide weather/sun/wind protection where possible</li> </ul>                                    |

## 6.8 Wellness Rooms

### Rationale

Wellness Rooms provide safe, quiet, and inclusive spaces that support a variety of personal needs, such as prayer, meditation, lactation, rest and decompression. These spaces are essential for creating environments that respect cultural, spiritual and personal practices while also supporting health and well-being.

Designing Wellness Rooms with accessibility in mind ensures that individuals of all abilities can use the space independently and with dignity. Features such as adequate manoeuvring space, accessible seating, quiet acoustics, and options for reclining allow the room to meet diverse needs. Providing flexible design supports not only individual wellness but also inclusion, equity and a sense of belonging within municipal facilities.

### Application

This section applies to Wellness Rooms provided in municipal facilities intended for staff, visitors, and the public. These rooms may serve multiple purposes, including prayer, meditation, lactation, personal wellness, or quiet reflection.

Wellness Rooms must be designed to:

- Support diverse cultural, spiritual and personal practices
- Provide a private, quiet and comfortable environment
- Be located on accessible routes and in proximity to universal washrooms or ablution facilities where required
- Include flexible features accommodating adults, children and caregivers

### Requirements

Wellness rooms must:

- Provide a minimum turning radius of 2500 mm for manoeuvring mobility devices
- Provide accessible seating, including a range of fixed and movable seating options and chairs with and without armrests
- Include a place to recline or lie down (e.g., couch, bench or cot)
- Provide storage for personal items (e.g., shoes, bags, mobility aids) without obstructing circulation
- Incorporate signage identifying the space as a Wellness Room in compliance with Section 5.7 Signage and Wayfinding

- Surfaces must be firm and slip-resistant with carpet or matting considered where kneeling or sitting on the floor is common
- Lighting must be dimmable and glare-free; natural light preferred where feasible
- Ensure acoustics provide quiet, private and comfortable use of the space
- Provide power outlets within reach ranges for personal devices or medical equipment
- Provide nearby access to washrooms and, where required, ablution or cleansing facilities
- See also Sections 2.1 (Space and Reach Requirements), 5.9 (Signage and Wayfinding), and 5.5 (Acoustics) for related requirements

**Table 97: Wellness Rooms at a Glance**

| <b>Feature</b>              | <b>Minimum / Recommended Dimensions</b>  | <b>Notes / Key Requirements</b>   |
|-----------------------------|--|---|
| <b>Turning Space</b>        | <ul style="list-style-type: none"> <li>• <math>\geq 2500</math> mm diameter</li> </ul> | <ul style="list-style-type: none"> <li>• Clear manoeuvring inside room</li> </ul>                                   |
| <b>Signage</b>              | <ul style="list-style-type: none"> <li>• N/A</li> </ul>                                | <ul style="list-style-type: none"> <li>• Wellness Room signage per Section 5.9</li> </ul>                           |
| <b>Seating</b>              | <ul style="list-style-type: none"> <li>• N/A</li> </ul>                                | <ul style="list-style-type: none"> <li>• Accessible seating with/without armrests</li> </ul>                        |
| <b>Recline / Rest Space</b> | <ul style="list-style-type: none"> <li>• N/A</li> </ul>                                | <ul style="list-style-type: none"> <li>• Provide couch, bench or cot</li> </ul>                                     |
| <b>Flooring</b>             | <ul style="list-style-type: none"> <li>• N/A</li> </ul>                                | <ul style="list-style-type: none"> <li>• Firm, stable</li> <li>• Carpet/matting acceptable</li> </ul>               |
| <b>Lighting</b>             | <ul style="list-style-type: none"> <li>• Adjustable</li> </ul>                         | <ul style="list-style-type: none"> <li>• Dimmable, glare-free, natural light preferred</li> </ul>                   |
| <b>Acoustics</b>            | <ul style="list-style-type: none"> <li>• N/A</li> </ul>                                | <ul style="list-style-type: none"> <li>• Sound-insulated, quiet environment</li> </ul>                              |
| <b>Storage</b>              | <ul style="list-style-type: none"> <li>• N/A</li> </ul>                                | <ul style="list-style-type: none"> <li>• Shoe or personal item storage</li> <li>• Not obstructing routes</li> </ul> |
| <b>Washroom Access</b>      | <ul style="list-style-type: none"> <li>• N/A</li> </ul>                                | <ul style="list-style-type: none"> <li>• Nearby universal/gender-neutral washroom</li> </ul>                        |
| <b>Ablution Facilities</b>  | <ul style="list-style-type: none"> <li>• N/A</li> </ul>                                | <ul style="list-style-type: none"> <li>• Where required, must be accessible</li> </ul>                              |

## **Cross-Reference**

See also Section 2.1 Space and Reach Requirements, Section 5.9 Signage and Wayfinding, and Section 5.5 Acoustics for related requirements on turning space, signage clarity, and sound control.

## **Technical Note – Accessible Wellness and Multi-Faith Spaces**

Designers should ensure Wellness Rooms balance privacy and inclusivity while meeting accessibility and safety standards.

Recommended reference standards include:

- CSA B651 (Accessible Design for the Built Environment)
- ISO 21542 (Building Construction – Accessibility and Usability of the Built Environment)
- WELL Building Standard (Mind and Comfort concepts)

Design teams should consult with accessibility and equity specialists to ensure the space accommodates diverse users and supports equitable well-being within municipal environments.

## 6.9 Cultural Art Facilities

### Rationale

Cultural art facilities must provide equitable and meaningful access to exhibits, performances, and cultural spaces. Design must accommodate diverse needs, using inclusive strategies and technologies such as tactile displays, audio descriptions, captioning, adjustable lighting, and clear navigation aids. Accessible design ensures equitable participation, interaction and enjoyment for all visitors.

### Application

This section applies to art and cultural facilities including, but not limited to, art galleries, museums, concert halls, theatres, heritage sites, and community or civic centres and other cultural venues open to the public.

### Design Requirements

#### Accessible Circulation

- Provide minimum clear width of 1100 mm along exhibit paths in accordance with Section 3.3 Interior Accessible Routes
- Provide clear floor space of at least 1500 mm x 1500 mm at turns or corners for wheelchair manoeuvring
- Maintain continuous, level flooring with no abrupt changes in height greater than 13 mm
- Provide accessible resting/seating areas at intervals not exceeding 30 m in large exhibit halls

#### Lighting

- Provide lighting that minimizes glare, shadows, and dark zones
- Incorporate anti-reflective coatings on fixtures and glass where possible
- Provide focused, adjustable accent lighting at 1200-1400 mm A.F.F. to highlight displays without glare.
- Meet Section 5.6 Lighting for additional illumination and glare control guidance, including:
  - 200–300 lux for general areas
  - 500 lux for detailed or tactile displays

## Communications and Information Systems

- Provide signage and wayfinding systems that:
  - Are high contrast, clear, and minimize visual clutter
  - Include tactile characters and Braille per Section 5.9 Signage and Wayfinding
  - Have minimum text height of 16 mm, mounted 1370–1525 mm above floor
- Provide assistive listening systems in accordance with Section 5.3 Assistive Listening Device and Public Telephones, covering at least 80% of audience area with minimal signal distortion
- Provide information in multiple accessible formats: large print (minimum 18 pt), audio, digital screen-reader compatible formats
- All multimedia content should be captioned and available with audio description

## Display Stands and Interactives

- Provide clear floor space of at least 1500 mm x 1500 mm around display stands
- Primary viewing surfaces must be 750–1200 mm AFF
- Interactive controls must be within 400–1200 mm AFF, with 15–20° tilt recommended
- Table or work surface depth must not exceed 500 mm for forward reach; provide knee clearance 735 mm high x 480 mm deep x 900 mm wide
- Displays should be viewable from at least two sides
- Interactive displays must:
  - Be operable with one hand, requiring no pinching, twisting, or tight grasping
  - Be designed to support tactile, auditory, and visual feedback
- Where interactive elements are digital, ensure compatibility with assistive technologies such as screen readers, alternative input devices and closed captioning

## Safety and Stability

- Display stands must be stable, with wide base to prevent tipping
- Edges rounded or padded
- Durable, non-toxic finishes; frequent cleaning considered

## Maintenance and Inspection

Cultural and exhibition spaces must be regularly inspected to ensure that accessible routes, lighting, signage, tactile elements, and assistive technologies remain functional and compliant. Exhibit layouts and display heights should be reviewed periodically to confirm

clear circulation and sightlines are maintained, particularly following exhibit changes or temporary installations.

**Table 98: Cultural Art Facilities at a Glance**

| <b>Feature</b>              | <b>Minimum / Recommended Dimensions</b>  | <b>Notes / Key Requirements</b>  |
|-----------------------------|--|--|
| <b>Path Width</b>           | <ul style="list-style-type: none"> <li>• <math>\geq 1100</math> mm</li> </ul>  | <ul style="list-style-type: none"> <li>• Clear accessible routes</li> </ul>  |
| <b>Turning Space</b>        | <ul style="list-style-type: none"> <li>• <math>\geq 1500 \times 1500</math> mm</li> </ul>  | <ul style="list-style-type: none"> <li>• At turns/corners</li> </ul>   |
| <b>Slope</b>                | <ul style="list-style-type: none"> <li>• <math>\leq 1:20</math></li> </ul>   | <ul style="list-style-type: none"> <li>• Unless designed as ramps</li> </ul>   |
| <b>Surface Changes</b>      | <ul style="list-style-type: none"> <li>• <math>\leq 13</math> mm</li> </ul>  | <ul style="list-style-type: none"> <li>• Beveled where unavoidable</li> </ul>  |
| <b>Lighting Levels</b>      | <ul style="list-style-type: none"> <li>• 200–300 lux general</li> <li>• 500 lux detailed</li> </ul>                                      | <ul style="list-style-type: none"> <li>• Diffused, glare-free, anti-reflective</li> </ul>  |
| <b>Wall Sconce Height</b>   | <ul style="list-style-type: none"> <li>• 1200–1400 mm AFF</li> </ul>   | <ul style="list-style-type: none"> <li>• Highlight displays</li> <li>• Assist wayfinding</li> </ul>  |
| <b>Signage</b>              | <ul style="list-style-type: none"> <li>• Text <math>\geq 16</math> mm (tactile 1370–1525 mm AFF)</li> </ul>                              | <ul style="list-style-type: none"> <li>• High contrast</li> <li>• Tactile and Braille</li> </ul>   |
| <b>Assistive Listening</b>  | <ul style="list-style-type: none"> <li>• Covering <math>\geq 80\%</math> of audience seating area</li> </ul>                             | <ul style="list-style-type: none"> <li>• Minimal signal distortion</li> </ul>  |
| <b>Accessible Formats</b>   | <ul style="list-style-type: none"> <li>• N/A</li> </ul>  | <ul style="list-style-type: none"> <li>• Large print (<math>\geq 18</math> pt), audio, digital compatible</li> </ul>   |
| <b>Interactive Displays</b> | <ul style="list-style-type: none"> <li>• Controls 400–1200 mm AFF</li> </ul>   | <ul style="list-style-type: none"> <li>• Operable with one hand</li> <li>• Tables <math>\leq 860</math> mm AFF with knee clearance</li> </ul>                              |
| <b>Display Stands</b>       | <ul style="list-style-type: none"> <li>• Viewing 750–1200 mm AFF</li> <li>• Clear space <math>\geq 1500 \times 1500</math> mm</li> </ul> | <ul style="list-style-type: none"> <li>• Max depth 500 mm</li> <li>• Knee clearance 750 mm high <math>\times</math> 480 mm deep <math>\times</math> 850 mm wide</li> </ul> |
| <b>Visual Accessibility</b> | <ul style="list-style-type: none"> <li>• Text <math>\geq 16</math> mm</li> <li>• 4.5:1 contrast ratio</li> </ul>                         | <ul style="list-style-type: none"> <li>• Sans serif fonts</li> <li>• Tactile/Braille where appropriate</li> </ul>  |
| <b>Safety / Stability</b>   | <ul style="list-style-type: none"> <li>• N/A</li> </ul>  | <ul style="list-style-type: none"> <li>• Rounded edges</li> <li>• Wide base</li> </ul>   |

| Feature | Minimum / Recommended Dimensions | Notes / Key Requirements   |
|---------|----------------------------------|--|
|         |                                  | <ul style="list-style-type: none"> <li>• Durable non-toxic finishes</li> </ul> |

### Cross-Reference

See also Sections 3.3 Interior Accessible Routes, 5.3 Assistive Listening Devices, 5.6 Lighting, and 5.9 Signage and Wayfinding for related accessibility requirements in circulation, communication, and visual design.

## Technical Note – Accessible Cultural and Exhibition Environments

Designers should ensure that cultural, performance, and exhibition spaces balance accessibility with artistic intent. Visual, auditory, and spatial accessibility features must enhance—not detract from—the visitor experience.

Reference standards and guidelines include:

- CSA B651 – Accessible Design for the Built Environment
- ISO 21542 – Building Construction: Accessibility and Usability of the Built Environment
- WELL Building Standard – Mind and Comfort concepts (sensory comfort and lighting)
- ICOM / UNESCO Museum Accessibility Guidelines – Inclusive exhibit and interpretive design best practices

Design teams should collaborate with accessibility specialists, curators, and end-users early in the design process to ensure inclusive, engaging, and equitable experiences for all visitors.

## 6.10 Accessible Playgrounds

### Rationale

Accessible playgrounds foster development, connection, and fun for children of all abilities. They provide equitable play opportunities, encourage interaction, and support caregivers of diverse ages and abilities.

Designing accessible playgrounds ensures that children and caregivers of all abilities can play, connect and participate safely and independently.

### Application

This section applies to play spaces, including play areas, playground equipment, sandboxes and other amenities. Play spaces may be located in a variety of public settings including parks and community or recreation centres.

Play spaces require consideration for:

- The number and types of play structures, equipment and features provided
- Designated play areas surrounding structures
- Site amenities and features surrounding the play space

Criteria provided in this section is intended to summarize key features for accessible playgrounds and reference applicable standards.

### Design Requirements

#### Consultation Requirements

Before constructing new or redeveloping existing outdoor play spaces, the City will consult on the needs of children and caregivers with various disabilities with:

- The Mississauga Accessibility Advisory Committee
- The public and people with disabilities

Consultation must address requirements for accessible play elements for children and caregivers with various disabilities including, but not limited to, sensory and active play components.

#### General Features

Children's play spaces must:

- Comply with current CAN/CSA Z614-14 Annex H

- Provide sensory, active and passive play components for children and caregivers with various disabilities
- Provide sufficient clearance for movement throughout the space

### **Surfaces**

- Firm and stable
- Have impact attenuation for fall safety
- Provide adequate drainage to prevent water accumulation

### **Play Equipment and Components**

- Provide at least 70% colour contrast between components and surroundings

### **Amenities**

Where provided, play spaces should include:

- Where parking is provided, accessible parking per Section 3.1 Parking and Loading Zones
- Waste and recycling receptacles that meet Section 3.7 Street Furniture

Table 99: Inclusive Play Spaces at a Glance

| Feature                          | Minimum / Recommended Dimensions  | Notes / Key Requirements   |
|----------------------------------|---|--|
| <b>Consultation</b>              | <ul style="list-style-type: none"> <li>N/A</li> </ul>   | <ul style="list-style-type: none"> <li>Consult Mississauga AAC</li> <li>The public</li> <li>People with disabilities</li> <li>Address sensory and active play needs</li> </ul>                         |
| <b>General Features</b>          | <ul style="list-style-type: none"> <li>N/A</li> </ul>   | <ul style="list-style-type: none"> <li>Comply with CAN/CSA Z614-14 Annex H</li> <li>Provide sensory, active, and passive play components</li> <li>Sufficient clearance for circulation</li> </ul>      |
| <b>Accessible Path of Travel</b> | <ul style="list-style-type: none"> <li>1800 mm min (2100 mm preferred)</li> <li>3000 mm if vehicle access required</li> </ul> | <ul style="list-style-type: none"> <li>Connect from parking/sidewalks/buildings</li> <li>Tactile orientation map at entrance</li> <li>Low-effort doors</li> <li>Childproof accessible gates</li> </ul> |
| <b>Surfaces</b>                  | <ul style="list-style-type: none"> <li>N/A</li> </ul>   | <ul style="list-style-type: none"> <li>Firm, stable, slip-resistant; impact-attenuating</li> <li>Beveled/flush transitions</li> <li>Adequate drainage</li> <li>Tactile cues where possible</li> </ul>  |
| <b>Handrails</b>                 | <ul style="list-style-type: none"> <li>560–965 mm; 510–710 mm at ramps; 24–39 mm diameter</li> </ul>                          | <ul style="list-style-type: none"> <li>Provided on play equipment</li> <li>Comply with Section 1.5 Handrails</li> </ul>  |
| <b>Guards</b>                    | <ul style="list-style-type: none"> <li>As per Section 1.4</li> </ul>  | <ul style="list-style-type: none"> <li>Required on elevated play equipment</li> </ul>  |
| <b>Play Equipment – Contrast</b> | <ul style="list-style-type: none"> <li>≥70%</li> </ul>  | <ul style="list-style-type: none"> <li>Colour/tonal contrast between play components and surroundings</li> </ul>   |
| <b>Play Equipment – Active</b>   | <ul style="list-style-type: none"> <li>N/A</li> </ul>   | <ul style="list-style-type: none"> <li>Climbing, motion, movement features</li> </ul>  |

| Feature                              | Minimum / Recommended Dimensions  | Notes / Key Requirements  |
|--------------------------------------|---|---|
| Play Equipment – Passive/Sensory     | <ul style="list-style-type: none"> <li>• N/A</li> </ul>   | <ul style="list-style-type: none"> <li>• Quiet zone outside active play</li> <li>• Clear sightlines</li> <li>• At least one sensory engagement</li> </ul> |
| Play Equipment – Distribution        | <ul style="list-style-type: none"> <li>• ≥50% ground-level; ≥50% elevated (rounded up)</li> </ul> | <ul style="list-style-type: none"> <li>• Accessible and adjustable</li> <li>• Dispersed throughout play space</li> </ul>                                  |
| Play Equipment – Clear Ground Space  | <ul style="list-style-type: none"> <li>• 900 × 1500 mm (front); 900 × 2200 mm (side)</li> </ul>   | <ul style="list-style-type: none"> <li>• At play components</li> </ul>  |
| Play Equipment – Reach Ranges        | <ul style="list-style-type: none"> <li>• Ages 2–5: 460–910 mm; Ages 5–12: 460–1020 mm</li> </ul>  | <ul style="list-style-type: none"> <li>• Accessible reach for children of different ages</li> </ul>   |
| Play Equipment – Mobility Device Use | <ul style="list-style-type: none"> <li>• ≥2 types of equipment</li> </ul>                         | <ul style="list-style-type: none"> <li>• Must be usable by children using mobility devices</li> </ul>   |
| Transfer Platforms                   | <ul style="list-style-type: none"> <li>• 280–460 mm height</li> </ul>                             | <ul style="list-style-type: none"> <li>• Connect ground and elevated play components (see Figure 61)</li> </ul>   |
| Transfer Steps                       | <ul style="list-style-type: none"> <li>• Per Section 1.4 Exterior Stairs</li> </ul>               | <ul style="list-style-type: none"> <li>• Adjacent clear ground space 900 × 1500 mm (front) or 900 × 2200 mm (side) (see Figure 62)</li> </ul>             |
| Amenities – Parking                  | <ul style="list-style-type: none"> <li>• Per Section 3.1</li> </ul>                               | <ul style="list-style-type: none"> <li>• Accessible parking/loading nearby</li> </ul>   |
| Amenities – Seating                  | <ul style="list-style-type: none"> <li>• N/A</li> </ul>   | <ul style="list-style-type: none"> <li>• Benches with weather protection and clear sightlines to play zones</li> </ul>                                    |
| Amenities – Waste/Recycling          | <ul style="list-style-type: none"> <li>• N/A</li> </ul>   | <ul style="list-style-type: none"> <li>• Receptacles per Section 3.7 Street Furniture</li> </ul>  |
| Amenities – Caregiver Fitness        | <ul style="list-style-type: none"> <li>• N/A</li> </ul>   | <ul style="list-style-type: none"> <li>• Consider adult fitness elements for caregiver engagement</li> </ul>  |

## Cross-Reference

See also Sections 1.4 Stairs, 1.5 Handrails, 2.1 Space and Reach Requirements, 3.1 Parking

and Loading Zones, 3.3 Exterior Accessible Paths of Travel, and 3.7 Street Furniture for related design and dimensional criteria.

## Technical Note – Inclusive Play Design

Accessible playgrounds must integrate accessibility into every aspect of layout, surfacing, equipment selection, and amenity design. Play environments should support physical, sensory, and social interaction for children of all abilities and their caregivers.

Reference standards and guidelines include:

- **CAN/CSA Z614-14 Annex H** – Children’s Playground Equipment and Surfacing
- **ISO 21542** – Building Construction: Accessibility and Usability of the Built Environment
- **Inclusive Play Design Guide (Canadian Tire Jumpstart & Rick Hansen Foundation)** – Best practices for sensory and universal play
- **WELL Community Standard** – Comfort and Movement features supporting inclusive public environments

## 6.11 Lockers and Baggage Storage

### Rationale

Lockers and baggage storage must be designed to serve users of all abilities. Accessible lockers ensure that persons using mobility devices, children, or those with limited dexterity can independently store and retrieve belongings. Clear signage, intuitive operating mechanisms, and adjacent accessible seating support comfort, dignity, and independence.

Designing accessible lockers and baggage storage promotes independence and ensures equitable use across all facility types.

### Application

Where lockers or baggage storage units are provided in public or common-use areas, at least 10% (minimum one) must comply with this section.

### Requirements

#### Location and Access

- Accessible lockers must be located on an accessible route complying with Section 3.3 Interior Accessible Routes
- Aisle space in front of lockers must be 1370 mm deep by 810 mm wide for manoeuvring
- Accessible lockers must be evenly dispersed throughout locker areas

#### Reach and Mounting Heights

- Bottom shelf between 400 mm minimum AFF
- Top shelf 1200 mm maximum AFF
- At least 10% of coat hooks mounted no higher than 1100 mm AFF

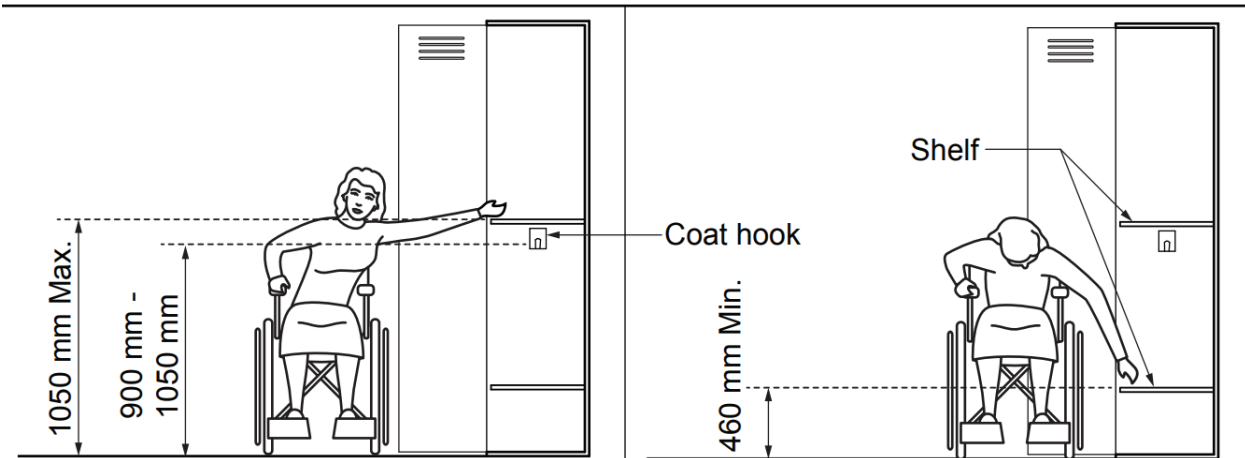

Figure 181: Reach range at lockers

### Clear Floor Space

- Forward approach: 915 mm wide by 1370 mm deep
- Side approach: 1525 mm wide by 915 mm deep

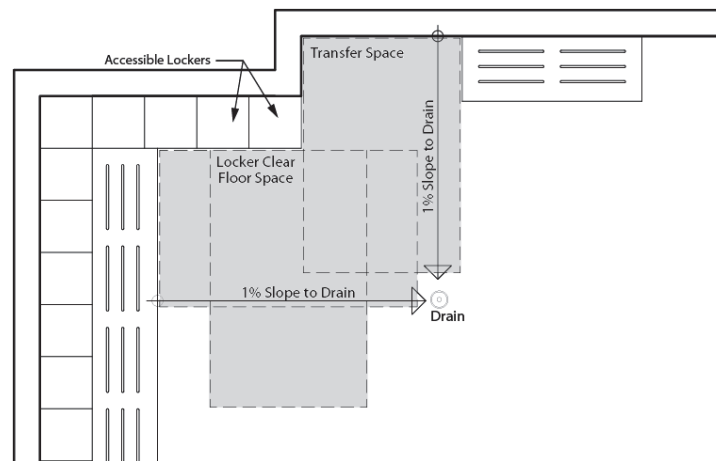

Figure 184: Locker Room Clear Floor Space Requirements

### Hardware and Operability

- Keys, codes, or cards (if used) must comply with Section 4.1 Controls and Operating Mechanisms
- Collapsible coat hooks are required; must not be mounted above benches

### Signage and Identification

- Accessible lockers identified with the International Symbol of Accessibility
- Locker numbering/signage

- Mounted no higher than 1500 mm (centreline)
- Lettering or number print size between 13 mm and 19 mm high, with either raised or recessed lettering
- High colour contrast with the background
- Tactile characters and Braille are recommended where lockers are numbered or assigned to users

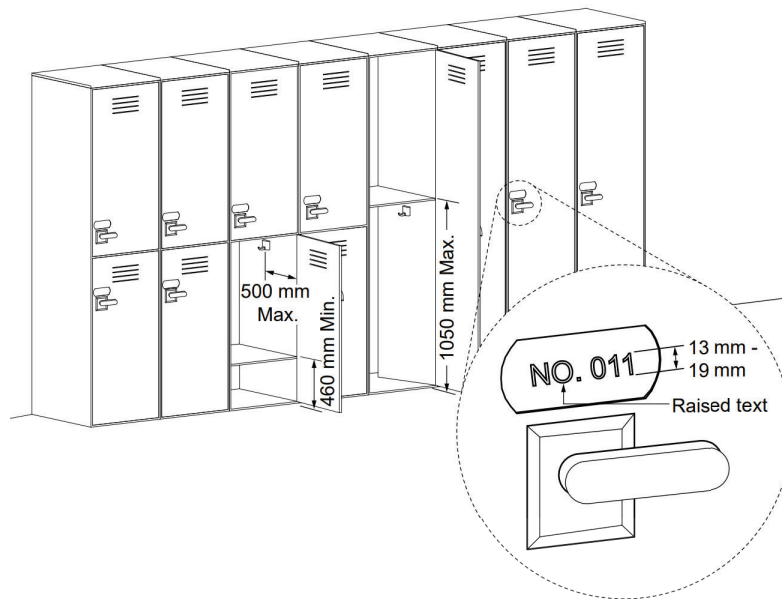

**Figure 182: Accessible Lockers**

### **Baggage Racks and Carousels**

- Platform surfaces no higher than 460 mm AFF
- Continuous colour-contrasting strip at leading edge
- Clear floor space and turning radius maintained

### **Benches (where provided)**

- Installed adjacent to accessible lockers
- Include back support and grab bars where practicable
- Provide adjacent clear floor space for transfer

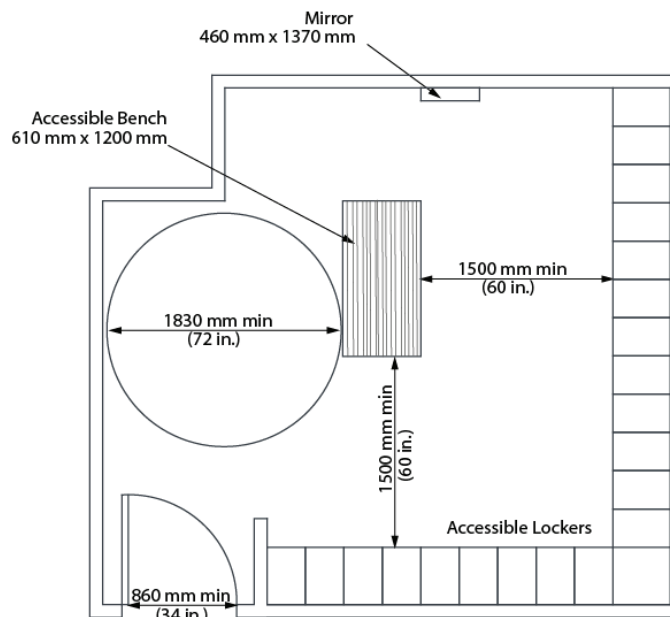

**Figure 183: Locker Room Sample Layout**

**Table 100: Lockers and Baggage Storage – At a Glance**

| Feature                     | Minimum / Recommended Dimensions  | Notes / Key Requirements  |
|-----------------------------|---|---|
| Accessible lockers required | <ul style="list-style-type: none"> <li>• <math>\geq 10\%</math> (min. 1)</li> </ul>   | <ul style="list-style-type: none"> <li>• Must be evenly dispersed</li> <li>• Located on an accessible route</li> </ul>                  |
| Aisle space                 | <ul style="list-style-type: none"> <li>• 1370 mm deep <math>\times</math> 810 mm wide</li> </ul>  | <ul style="list-style-type: none"> <li>• Required clear manoeuvring space in front of lockers</li> </ul>                                |
| Clear floor space           | <ul style="list-style-type: none"> <li>• 915 <math>\times</math> 1370 mm (forward)</li> <li>• 1525 <math>\times</math> 915 mm (side)</li> </ul> | <ul style="list-style-type: none"> <li>• Must be provided at accessible lockers</li> </ul>  |
| Bottom shelf                | <ul style="list-style-type: none"> <li>• <math>\geq 400</math> mm AFF</li> </ul>  | <ul style="list-style-type: none"> <li>• Within accessible reach range</li> </ul>   |
| Top shelf                   | <ul style="list-style-type: none"> <li>• <math>\leq 1200</math> mm AFF</li> </ul>   | <ul style="list-style-type: none"> <li>• Within accessible reach range</li> </ul>   |
| Locks                       | <ul style="list-style-type: none"> <li>• 900–1100 mm AFF</li> </ul>   | <ul style="list-style-type: none"> <li>• Operable with one hand</li> <li>• No tight grasping, pinching, or twisting</li> </ul>          |
| Coat hooks                  | <ul style="list-style-type: none"> <li>• <math>\leq 1100</math> mm AFF</li> </ul>   | <ul style="list-style-type: none"> <li>• At least 10% accessible</li> <li>• Collapsible</li> <li>• Not mounted above benches</li> </ul> |
| Signage / numbering         | <ul style="list-style-type: none"> <li>• 13–19 mm high text</li> <li>• <math>\leq 1500</math> mm AFF (centreline)</li> </ul>                    | <ul style="list-style-type: none"> <li>• Raised or recessed</li> <li>• High contrast</li> </ul>   |

| Feature                   | Minimum / Recommended Dimensions                                | Notes / Key Requirements  |
|---------------------------|---|---|
|                           |   | <ul style="list-style-type: none"> <li>• ISA symbol on accessible lockers</li> </ul>  |
| Baggage racks / carousels | <ul style="list-style-type: none"> <li>• ≤460 mm AFF</li> </ul> | <ul style="list-style-type: none"> <li>• Continuous colour-contrasting strip on platform edge</li> <li>• Clear floor space maintained</li> </ul>                              |
| Benches (where provided)  | <ul style="list-style-type: none"> <li>• N/A</li> </ul>         | <ul style="list-style-type: none"> <li>• Adjacent to accessible lockers</li> <li>• Back support and grab bars where practicable</li> <li>• Transfer space provided</li> </ul> |

### Cross-Reference

See also Sections 2.1 Space and Reach Requirements, 3.3 Interior Accessible Routes, 4.1 Controls and Operating Mechanisms, and 5.7 Signage and Wayfinding for related reach, clearance, operability, and signage standards.

### Maintenance and Inspection

Lockers, baggage racks, and storage systems should be regularly inspected to ensure operability, stability, and accessibility. Locks, hooks, and signage must remain functional, readable, and mounted at compliant heights. Periodic checks should confirm that clear floor spaces and accessible routes remain unobstructed and that adjustable or mechanical components operate with minimal force.

## 6.12 Fire Stations

### Rationale

Municipal fire stations must accommodate accessibility needs of all potential users. While many areas are dedicated to firefighters and not intended for public use, stations also serve administrative staff, consultants, school groups, visitors, and members of the public in emergency situations. Applying accessibility standards within these specialized facilities supports inclusion and ensures that all users – from firefighters to visitors – can navigate and interact with safety and independence.

### Application

This section applies to areas of fire stations that are accessible to the public or intended for viewing by visitors.

**Exception:** Facilities used exclusively by firefighters (hose towers, fitness rooms, dormitories, second floors, and basement storage).

At least one accessible public washroom must be provided.

### Requirements

#### Entrances and Paths of Travel

- Public entrances must be accessible and comply with Section 3.2 Entrances and Doors
- Firefighter entrances must comply with Section 3.2, except power door operators are not required unless mandated by the OBC
- Where more than 3 entrances are provided, at least 2 must be barrier-free (OBC)
- Provide an accessible path of travel per Section 3.3 Interior Accessible Routes from accessible entrances to all public or visitor areas
- Signage must identify accessible entrances in compliance with Section 5.9 Signage and Wayfinding

#### Public and Community-Use Areas

- Any spaces intended for public or community use (e.g., meeting rooms, classrooms, multi-purpose rooms) must comply fully with this Standard
- Kitchens or kitchenette facilities intended for public or shared use must comply with Section 6.6 Kitchens and Kitchenettes
- Apparatus bays and designated public viewing areas must be on an accessible route and provide safe, clear sightlines with appropriate barriers or guards

## Accessible Washrooms

- Provide at least one accessible public washroom
- Washrooms must comply with Section 3.7 Washrooms except:
  - Adult-sized change table is not required, but sufficient space must be provided for one (minimum 1800 mm long x 700 mm wide clear area)
  - A baby change table must be included
- Install accessible signage at washrooms (tactile and high-contrast) per Section 5.9 Signage and Wayfinding
- An emergency call system should be provided inside accessible washrooms

## Parking

- Where public parking is provided, at least one accessible space must be located close to the primary public entrance
- Parking must comply with Section 4.1 Parking and Loading Zones

**Table 101: Fire Stations – At a Glance**

| <b>Feature</b>                    | <b>Minimum/Recommended Dimensions</b>   | <b>Notes / Key Requirements</b>  |
|-----------------------------------|---|--|
| <b>Public entrances</b>           | <ul style="list-style-type: none"> <li>• N/A</li> </ul>   | <ul style="list-style-type: none"> <li>• Must be accessible</li> <li>• Comply with Section 3.2 Entrances and Doors</li> </ul>                                  |
| <b>Firefighter entrances</b>      | <ul style="list-style-type: none"> <li>• N/A</li> </ul>   | <ul style="list-style-type: none"> <li>• Must comply with Section 3.2</li> <li>• Power door operators not required unless mandated by OBC</li> </ul>           |
| <b>Barrier-free entrances</b>     | <ul style="list-style-type: none"> <li>• <math>\geq 2</math> where <math>&gt;3</math> provided</li> </ul> | <ul style="list-style-type: none"> <li>• OBC requirement</li> </ul>  |
| <b>Accessible path of travel</b>  | <ul style="list-style-type: none"> <li>• 1100 mm clear width minimum</li> </ul>                           | <ul style="list-style-type: none"> <li>• From accessible entrances to all public/visitor areas, per Section 3.3 Interior Accessible Routes</li> </ul>          |
| <b>Entrance signage</b>           | <ul style="list-style-type: none"> <li>• Mounted 1370–1525 mm AFF</li> </ul>                              | <ul style="list-style-type: none"> <li>• Identify accessible entrances</li> <li>• Tactile and high contrast, per Section 5.9 Signage and Wayfinding</li> </ul> |
| <b>Public/community-use areas</b> | <ul style="list-style-type: none"> <li>• N/A</li> </ul>   | <ul style="list-style-type: none"> <li>• Meeting rooms, classrooms, multi-purpose rooms must comply with this Standard</li> </ul>                              |

| Feature                                 | Minimum/Recommended Dimensions   | Notes / Key Requirements  |
|---|--|---|
| <b>Kitchens (shared/public)</b>         | <ul style="list-style-type: none"> <li>N/A</li> </ul>                      | <ul style="list-style-type: none"> <li>Must comply with Section 6.6 Kitchens and Kitchenettes</li> </ul>  |
| <b>Apparatus bay / viewing</b>          | <ul style="list-style-type: none"> <li>N/A</li> </ul>                      | <ul style="list-style-type: none"> <li>Must be on an accessible route with safe, clear sightlines and protective barrier/guard</li> </ul>   |
| <b>Accessible washroom</b>              | <ul style="list-style-type: none"> <li>At least 1</li> </ul>               | <ul style="list-style-type: none"> <li>Must comply with Section 3.7 Washrooms</li> <li>Adult change table space required but not the fixture</li> <li>Baby change table required</li> </ul> |
| <b>Washroom signage</b>                 | <ul style="list-style-type: none"> <li>Mounted 1370–1525 mm AFF</li> </ul> | <ul style="list-style-type: none"> <li>Tactile and high contrast, per Section 5.9 Signage and Wayfinding</li> </ul>   |
| <b>Emergency call system (washroom)</b> | <ul style="list-style-type: none"> <li>N/A</li> </ul>                      | <ul style="list-style-type: none"> <li>Should be provided inside accessible washrooms</li> </ul>  |
| <b>Accessible parking</b>               | <ul style="list-style-type: none"> <li>≥1 space</li> </ul>                 | <ul style="list-style-type: none"> <li>Close to primary public entrance, must comply with Section 4.1 Parking and Loading Zones</li> </ul>  |

## Cross-Reference

See also Sections 3.2 Doors and Doorways, 3.3 Interior Accessible Routes, 4.1 Parking and Loading Zones, 3.7 Washrooms, 5.9 Signage and Wayfinding, and 6.6 Kitchens and Kitchenettes for related requirements on access routes, washrooms, signage, and shared spaces.

## Maintenance and Inspection

Fire stations must be inspected periodically to ensure that accessible entrances, washrooms, signage, and public areas remain free of barriers and fully functional. Public viewing areas and apparatus bays should be reviewed regularly to confirm that guards, sightlines, and circulation routes continue to provide safe and accessible viewing conditions for all users.

## 6.13 Municipal Courts

### Rationale

Municipal court facilities must be inclusive for all participants and visitors, including members of the judiciary, court clerks and staff, defendants, counsel, witnesses, press, and the public. Accessibility promotes fairness, safety, and dignity by ensuring equal participation in judicial processes. While some areas (e.g., judges' benches, witness stands) may be raised, they must be designed for adaptability so they can be modified with minimal reconstruction if accessibility is required in the future. Integrating accessibility within court environments reinforces procedural fairness and demonstrates the City's commitment to equal access to justice.

### Application

This section applies to all public and staff-accessible areas of municipal courts, including entrances, security screening, courtrooms, jury areas, and supporting facilities. Detention-only zones used exclusively by security staff and detainees may be exempt from hardware requirements but should be designed to allow adaptation where practicable.

### Design Requirements

#### Entrances and Security

- At least one restricted entrance (for judges, staff, or authorized users) and one secure entrance (for detainees and security staff) must be accessible
- Where screening devices (e.g., metal detectors, x-ray machines) cannot accommodate mobility devices, provide an adjacent accessible route with equivalent circulation
- Security counters, glazing, and pass-throughs must comply with Section 3.6 Service Counters

#### Accessible Routes

- Provide accessible circulation to all public areas, jury assembly/deliberation spaces, and staff stations used by persons with disabilities
- Routes must comply with Section 3.3 Interior Accessible Routes and be free of barriers

#### Courtrooms

- Spectator and press seating:
  - For seating for less than 25 people: provide at least one wheelchair space within the defined area
  - For seating for more than 25 people: provide accessible seating per Section 6.1 Office and Meeting Space

- Jury boxes and witness stands: provide clear floor space; where raised, design for future lift or ramp installation without major reconstruction
- Judges' benches, clerks' stations, bailiffs' stations, court reporters' stations, and counsel tables:
  - Provide clear floor space, knee and toe clearance, and turning radius
  - Raised stations may be constructed adaptable for future vertical access
- All handrails, signage, lighting, and finishes must follow the requirements of their respective sections

### **Assistive Listening Systems**

- Permanently installed assistive listening system required in every courtroom
- Provide receivers for at least 4% of room occupant load (minimum 2)
- Post signage indicating availability, in compliance with Section 5.9 Signage and Wayfinding
- Use FM/infrared or induction loop technologies for hearing-aid compatibility
- All assistive listening equipment must be tested regularly to ensure functionality and signal clarity

### **Jury Assembly and Deliberation Areas**

- Refreshment counters, kitchenettes, and vending areas must be accessible
- Drinking fountains must comply with Section 2.10 Drinking Fountains and Bottle Filling Stations
- Provide accessible washrooms in or adjacent to jury assembly areas

### **Washrooms**

- Provide at least one accessible public washroom on each floor with courtroom facilities
- Washrooms must comply with Section 3.7 Washrooms

### **Detention and Secure Areas**

- Spaces used for detainee holding and transfer should be designed to allow accessibility adaptation where possible without compromising security

Table 102: Municipal Courts – At a Glance

| Feature                                       | Minimum/Recommended Dimensions   | Notes / Key Requirements  |
|---|--|---|
| <b>Entrances</b>                              | <ul style="list-style-type: none"> <li>N/A</li> </ul>  | <ul style="list-style-type: none"> <li>At least one restricted entrance and one secure entrance must be accessible</li> <li>Provide adjacent accessible route where screening devices are not usable</li> </ul>               |
| <b>Accessible Routes</b>                      | <ul style="list-style-type: none"> <li>Per Section 2.3 Interior Accessible Routes</li> </ul>                                 | <ul style="list-style-type: none"> <li>Required to all public areas, jury assembly/deliberation, and staff stations</li> </ul>  |
| <b>Spectator &amp; Press Seating</b>          | <ul style="list-style-type: none"> <li>≥1 clear floor space if ≤25 seats</li> <li>Per Section 6.2 if &gt;25 seats</li> </ul> | <ul style="list-style-type: none"> <li>Accessible seating integrated into seating areas</li> </ul>  |
| <b>Jury Boxes &amp; Witness Stands</b>        | <ul style="list-style-type: none"> <li>Clear floor space per Section 2.1 Space &amp; Reach</li> </ul>                        | <ul style="list-style-type: none"> <li>Must allow future adaptation with lift or ramp where raised</li> </ul>   |
| <b>Judges' Bench &amp; Staff Stations</b>     | <ul style="list-style-type: none"> <li>Clear floor space and turning space</li> </ul>  | <ul style="list-style-type: none"> <li>Must be adaptable for future vertical access</li> <li>Counsel tables and stations designed for mobility device access</li> </ul>   |
| <b>Assistive Listening Systems</b>            | <ul style="list-style-type: none"> <li>Receivers for ≥4% of occupant load (min 2)</li> </ul>                                 | <ul style="list-style-type: none"> <li>Permanently installed system required in each courtroom</li> <li>Signage must indicate availability</li> </ul>   |
| <b>Jury Assembly &amp; Deliberation Areas</b> | <ul style="list-style-type: none"> <li>N/A</li> </ul>  | <ul style="list-style-type: none"> <li>Accessible refreshment counters, kitchenettes, vending areas, and drinking fountains</li> </ul>  |
| <b>Washrooms</b>                              | <ul style="list-style-type: none"> <li>Per Section 3.7 Washrooms</li> </ul>  | <ul style="list-style-type: none"> <li>At least one accessible public washroom per floor</li> <li>Baby change table required</li> <li>Space for adult-size change table recommended</li> <li>Emergency call system</li> </ul> |

| Feature        | Minimum/Recommended Dimensions   | Notes / Key Requirements   |
|----------------|--|--|
| <b>Signage</b> | <ul style="list-style-type: none"> <li>• Lettering min 13 mm high</li> <li>• Tactile, high contrast</li> </ul> | <ul style="list-style-type: none"> <li>• Required at washrooms and assistive listening system locations</li> </ul> |

### Cross-Reference

See also Sections 3.3 Interior Accessible Routes, 4.4 Service Counters, 5.7 Assembly Areas, 5.7 Signage and Wayfinding, 6.7 Drinking Fountains, and 6.8 Washrooms for detailed technical requirements on routes, seating, signage, and amenities referenced in this section.

### Maintenance and Inspection

Municipal court facilities should be inspected routinely to verify that accessible routes, seating areas, signage, and assistive listening systems remain functional and unobstructed. Equipment such as security screening devices, microphones, and lifts must be kept in good working order and tested periodically. Where courtroom layouts change, accessible circulation, sightlines, and seating must be reassessed to maintain compliance and user independence.